

Montana Tech Library

Digital Commons @ Montana Tech

Silver Bow Creek/Butte Area Superfund Site

Montana Superfund

Spring 6-29-2022

**Draft Final Butte Reduction Works (BRW) Smelter Area Mine
Waste Remediation and Contaminated Groundwater Hydraulic
Control Site Phase III Quality Assurance Project Plan (QAPP**

Pioneer Technical Services, Inc.

Follow this and additional works at: https://digitalcommons.mtech.edu/superfund_silverbowbutte



Part of the [Environmental Health and Protection Commons](#), [Environmental Indicators and Impact Assessment Commons](#), and the [Environmental Monitoring Commons](#)

Atlantic Richfield Company

Josh Bryson
Liability Manager

317 Anaconda Road
Butte MT 59701
Direct (406) 782-9964
Fax (406) 782-9980

June 29, 2022

Nikia Greene
Remedial Project Manager
US EPA – Montana Office
Baucus Federal Building
10 West 15th Street, Suite 3200
Helena, Montana 59626

Erin Agee
Senior Assistant Regional Counsel
US EPA Region 8 Office of Regional Counsel
CERCLA Enforcement Section
1595 Wynkoop Street
Denver, CO 80202
Mail Code: 8ORC-C

Daryl Reed
DEQ Project Officer
P.O. Box 200901
Helena, Montana 59620-0901

Jonathan Morgan, Esq.
DEQ, Legal Counsel
P.O. Box 200901
Helena, Montana 59620-0901

RE: Draft Final Butte Reduction Works (BRW) Smelter Area Mine Waste Remediation and Contaminated Groundwater Hydraulic Control Site Phase III Quality Assurance Project Plan (QAPP)

Agency Representatives:

I am writing you on behalf of Atlantic Richfield Company (Atlantic Richfield) to submit the Agency-requested annual update to the *Draft Final Butte Reduction Works (BRW) Smelter Area Mine Waste Remediation and Contaminated Groundwater Hydraulic Control Site Phase III Quality Assurance Project Plan (QAPP)* (BRW Phase III QAPP) for your review.

The BRW Phase III QAPP has been revised to reflect changes in the technical approach as well as to incorporate additional field investigation activities planned for 2022 including the following:

- Collect Silver Bow Creek sediment samples for particle size distribution near the upstream and downstream tie in locations of the realigned stream and 100-year floodplain. The sediment sample particle size distribution will support the stream design.
- Collect samples from soil cores that were retrieved from the BRW Site during the Phase I Site Investigation activities and archived at the Pioneer field office. Analyze the samples for chemical stability/leachability which will be used to refine the estimate of chemical leachability of slag within the BRW Site and the extents of a potential highly leachable soil layer near piezometer BRW18-PZ08.

It should be noted that Atlantic Richfield is proposing to change the level of data validation for the data collected as part of the BRW Phase III QAPP from Stage 4 to Stage 2A. This change in approach will not affect the Data Quality Objectives because the data collected will still be validated to ensure it meets the project objectives and is able to be used for the remedial design. Atlantic Richfield is

Atlantic Richfield Company

Josh Bryson
Liability Manager

317 Anaconda Road
Butte MT 59701
Direct (406) 782-9964
Fax (406) 782-9980

proposing this change because (1) a significant amount of data was collected as part of the BRW Phase I and II Site Investigation activities and this data has undergone Level 4 data validation as defined in *EPA Guidance for Labeling Externally Validated Laboratory Analytical Data for Superfund Use*, and (2) Stage 2A data validation would be consistent with other projects scoped within the Butte Priority Soils Operable Unit (BPSOU) Consent Decree (CD).

Per Agencies' request, the following documents are included with this submittal:

1. Word Document QAPP Crosswalk.
2. Word Document of the BRW Phase III QAPP with redline text indicating edits from the previous version approved by Agencies.
3. Complete PDF of BRW Phase III QAPP.

The documents may be downloaded at the following link:

<https://pioneertechnicalservices.sharepoint.com/:f:/s/submitted/EnATyrFpcUpOv5Y4o05L69cBQMn8taGiwj9mNFQ-NDFvtg>.

If you have any questions or comments, please call me at (406) 723-1834.

Sincerely,



Josh Bryson, PE, PMP
Liability Manager
Remediation Management Services Company
An affiliate of **Atlantic Richfield Company**

Cc: Patricia Gallery / Atlantic Richfield - email
Chris Greco / Atlantic Richfield – email
Mike Mc Anulty / Atlantic Richfield - email
Loren Burmeister / Atlantic Richfield – email
Dave Griffis / Atlantic Richfield - email
Jean Martin / Atlantic Richfield - email
Irene Montero / Atlantic Richfield - email
David A. Gratson / Environmental Standards / email
Mave Gasaway / DGS - email
Brianna McClafferty / Holland & Hart - email

Joe Vranka / EPA - email
David Shanight / CDM - email
Curt Coover / CDM - email
James Freeman / DOJ - email
John Sither / DOJ - email
Dave Bowers / DEQ - email
Carolina Balliew / DEQ - email
Matthew Dorrington / DEQ – email
Wil George / DEQ – email
Jim Ford / NRDP - email
Pat Cunneen / NRDP - email
Harley Harris / NRDP - email
Katherine Hausrath / NRDP - email
Meranda Flugge / NRDP - email
Ted Duaime / MBMG - email
Gary Icopini / MBMG - email
Becky Summerville / MR - email
Kristen Stevens / UP - email
Robert Bylsma / UP - email
John Gilmour / Kelley Drye - email
Leo Berry / BNSF - email
Robert Lowry / BNSF - email
Brooke Kuhl / BNSF – email
Lauren Knickrehm / BNSF - email
Jeremie Maehr / Kennedy Jenks - email
Annika Silverman / Kennedy Jenks - email
Matthew Mavrincac / RARUS - email
Harrison Roughton / RARUS - email
Brad Gordon / RARUS - email
Mark Neary / BSB - email
Eric Hassler / BSB - email
Julia Crain / BSB - email
Chad Anderson / BSB - email
Brandon Warner / BSB – email
Abigail Peltomaa / BSB - email
Eileen Joyce / BSB – email
Sean Peterson/BSB – email
Gordon Hart / BSB – email
Jeremy Grotbo / BSB – email
Karen Maloughney / BSB – email
Josh Vincent / WET - email
Craig Deeney / TREC - email
Scott Bradshaw / TREC - email
Brad Archibald / Pioneer - email
Pat Sampson / Pioneer - email
Joe McElroy / Pioneer – email

Andy Dare / Pioneer – email
Karen Helfrich / Pioneer - email
Leesla Jonart / Pioneer - email
Randa Colling / Pioneer – email
Ian Magruder/ CTEC- email
CTEC of Butte / email
Scott Juskiewicz / Montana Tech – email

File: MiningSharePoint@bp.com - email
BPSOU SharePoint - upload

**SILVER BOW CREEK/BUTTE AREA NPL SITE
BUTTE PRIORITY SOILS OPERABLE UNIT**

2022

Draft Final

***Butte Reduction Works (BRW) Smelter Area Mine
Waste Remediation and Contaminated Groundwater
Hydraulic Control Site
Phase III Quality Assurance Project Plan (QAPP)***

***Atlantic Richfield Company
317 Anaconda Road
Butte, Montana 59701***

Revision 1. June 2022

**SILVER BOW CREEK/BUTTE AREA NPL SITE
BUTTE PRIORITY SOILS OPERABLE UNIT**

2022

Draft Final

***Butte Reduction Works (BRW) Smelter Area Mine
Waste Remediation and Contaminated Groundwater
Hydraulic Control Site
Phase III Quality Assurance Project Plan (QAPP)***

Prepared for:

Atlantic Richfield Company
317 Anaconda Road
Butte, Montana 59701

Prepared by:

Pioneer Technical Services, Inc.
1101 S. Montana Street
Butte, Montana 59701

Revision 1. June 2022

APPROVAL PAGE

**Silver Bow Creek/Butte Area NPL Site
Butte Reduction Works Smelter Area Mine Waste Remediation and Contaminated
Groundwater Hydraulic Control Site Phase III Quality Assurance Project Plan**

Approved: _____ Date: _____
Nikia Greene, Site Project Manager, EPA, Region 8

Approved: _____ Date: _____
Daryl Reed, Project Officer, Montana DEQ

Approved: _____ Date: _____
Josh Bryson, Liability Manager
Atlantic Richfield Company

Approved: _____ Date: _____
David Gratson, Quality Assurance Manager
Environmental Standards, Inc.

Plan is effective on date of approval.

DOCUMENT REVISION TRACKING TABLE

Revision No.	Author	Version	Description	Date
Rev 0	K. Helfrich	Final	Issued for Agency Approval	04/30/2021
Rev 1	T. Biere	Draft Final	Revised for Agency Approval	06/29/2022

DISTRIBUTION LIST

Silver Bow Creek/Butte Area NPL Site Butte Reduction Works Smelter Area Mine Waste Remediation and Contaminated Groundwater Hydraulic Control Site Phase III Quality Assurance Project Plan

Key Personnel Recipients	Title	Organization	Telephone Number	E-mail Address
Nikia Greene	Remedial Project Manager	EPA	(406) 457-5019	Nikia.Greene@epa.gov
Erin Agee	Legal Counsel	EPA	(303) 312-6374	Erin.Agee@epa.gov
Daryl Reed	State Project Officer	DEQ	(406) 444-6433	dreed@mt.gov
Jonathan Morgan	Legal Counsel	DEQ	(406) 444-6589	JMorgan3@mt.gov
Josh Bryson	Liability Manager	Atlantic Richfield	(406) 782-9964	josh.bryson@bp.com
Irene Montero	Senior Technologist - RET Lead	Atlantic Richfield	(713) 538-0875	irene.montero@bp.com
David Gratson	Atlantic Richfield Quality Assurance Manager	Environmental Standards	(505) 660-8521	dgratson@envstd.com
David Shanight	EPA Contractor	CDM Smith	(406) 441-1400	ShanightDT@cdmsmith.com
Eric Hassler	Director, Department of Reclamation and Environmental Services	Butte-Silver Bow	(406) 497-5042	ehassler@bsb.mt.gov
Julia Crain	Assistant Director, Department of Reclamation and Environmental Services / Quality Assurance Manager	Butte-Silver Bow	(406) 497-6264	jcrain@bsb.mt.gov
Abigail Peltomaa	Manager, Data Management Division/Quality Assurance Officer	Butte-Silver Bow	(406) 497-5045	apeltoama@bsb.mt.gov
Chad Anderson	Manager, Human Health/RMAP Division	Butte-Silver Bow	(406) 497-6278	canderson@bsb.mt.gov
Brandon Warner	Manager, Environmental Division	Butte-Silver Bow	(406) 497-5022	bwarn@bsb.mt.gov
Jeremy Grotbo	GIS Data Specialist	Butte-Silver Bow	(406) 497-6261	jgrotbo@bsb.mt.gov
Pat Sampson	Atlantic Richfield Contractor – Project Oversight	Pioneer Technical Services, Inc.	(406) 490-0706	psampson@pioneer-technical.com

For Information Only Recipients	Organization	E-mail Address
Joe Vranka	EPA	vranka.joe@epa.gov
Jean Martin	Atlantic Richfield	jean.martin@bp.com
Brianne McClafferty	Holland & Hart	bcmclafferty@hollandhart.com
Mave Gasaway	Davis, Graham & Stubbs, LLP	Mave.Gasaway@dgsllaw.com
Patricia Gallery	Atlantic Richfield	patricia.gallery@bp.com
Loren Burmeister	Atlantic Richfield	loren.burmeister@bp.com
Irene Montero	Atlantic Richfield	irene.montero@bp.com
Chris Greco	Atlantic Richfield	chris.greco@bp.com
Dave Griffis	Atlantic Richfield	dave.griffis@bp.com
Mike Mc Anulty	Atlantic Richfield	meanume@bp.com
Curt Coover	CDM	CooverCA@cdmsmith.com
James Freeman	DOJ	james.freeman2@usdoj.gov
John Sither	DOJ	john.sither@usdoj.gov
Dave Bowers	DEQ	dbowers@mt.gov
Carolina Balliew	DEQ	carolina.balliew@mt.gov
Matthew Dorrington	DEQ	Matthew.Dorrington@mt.gov
Wil George	DEQ	william.george@mt.gov
John Gilmour	KelleyDrye	jgilmour@kelleydrye.com
Jim Ford	NRDP	jford@mt.gov
Pat Cunneen	NRDP	pcunneen@mt.gov
Harley Harris	NRDP	harleyharris@mt.gov
Katherine Hausrath	NRDP	KHausrath@mt.gov
Meranda Flugge	NRDP	nrdp@mt.gov
Ted Duaine	MBMG	TDuaine@mtech.edu
Gary Icopini	MBMG	gicopini@mtech.edu
Robert Bylsma	Union Pacific	rbylsma@up.com
Kristen Stevens	Union Pacific	kmstevens@up.com
Leo Berry	BNSF	leo@bkbh.com
Robert Lowry	BNSF	rlowry@kelrun.com
Brooke Kuhl	BNSF	brooke.kuhl@bnsf.com
Lauren Knickrehm	BNSF	lauren.knickrehm@bnsf.com
Jeremie Maehr	Kennedy/Jenks	jeremiemaehr@kennedyjenks.com
Annika Silverman	Kennedy/Jenks	annikasilverman@kennedyjenks.com
Matthew Mavrinac	RARUS	Matthew.Mavrinac@patriotrail.com
Harrison Roughton	RARUS	harrison.roughton@patriotrail.com
Brad Gordon	RARUS	Brad.Gordon@Patriotrail.com
Becky Summerville	MR	bsummerville@mtresourcesinc.com
Mark Neary	BSB	mneary@bsb.mt.gov
Jeremy Grotbo	BSB	jgrotbo@bsb.mt.gov
Eileen Joyce	BSB	ejoyce@bsb.mt.gov
Sean Peterson	BSB	speterson@bsb.mt.gov
Gordon Hart	BSB	gordonhart@paulhastings.com
Josh Vincent	WET	jvincent@waterenvtech.com
Craig Deeney	TREC	cdeeney@woodardcurran.com
Scott Bradshaw	TREC	sbradshaw@woodardcurran.com
Brad Archibald	Pioneer Technical Services, Inc.	barchibald@pioneer-technical.com
Joe McElroy	Pioneer Technical Services, Inc.	jmcelroy@pioneer-technical.com

For Information Only Recipients	Organization	E-mail Address
Andy Dare	Pioneer Technical Services, Inc.	adare@pioneer-technical.com
Karen Helfrich	Pioneer Technical Services, Inc.	khelfrich@pioneer-technical.com
Leesla Jonart	Pioneer Technical Services, Inc.	ljonart@pioneer-technical.com
Randa Colling	Pioneer Technical Services, Inc.	rcolling@pioneer-technical.com
Ian Magruder	Citizen's Environmental Technical Committee	ian_magruder@wwcengineering.com
CTEC of Butte	Citizen's Environmental Technical Committee	BUTTECTEC@hotmail.com
Montana Tech Library	Montana Tech	sjuskiewicz@mtech.edu
Mining SharePoint	Atlantic Richfield	MiningSharePoint@bp.com

TABLE OF CONTENTS

APPROVAL PAGE	I
DOCUMENT REVISION TRACKING TABLE	I
DISTRIBUTION LIST.....	II
TABLE OF CONTENTS	V
LIST OF FIGURES	VII
LIST OF TABLES	VII
LIST OF APPENDICES	VII
ACRONYMS.....	VIII
1.0 INTRODUCTION.....	1
1.1 Purpose of the Phase III Site Investigation	2
1.2 Objectives of the Phase III Site Investigation.....	3
2.0 BACKGROUND	5
2.1 Site Description.....	5
2.2 Site History	6
2.3 Relevant Previous Investigations.....	6
2.3.1 Preliminary Results from Phase I Site Investigation	6
2.3.2 Preliminary Results from Phase II Site Investigation.....	7
2.4 BRW Remedial Action	7
3.0 DATA QUALITY OBJECTIVES	8
3.1 Measurement Performance Criteria for Data	8
4.0 SAMPLING PROCESS AND DESIGN	11
4.1 Preparation for Fieldwork.....	11
4.1.1 Training.....	11
4.1.2 Property Access	12
4.1.3 Utility Locates.....	12
4.1.4 Best Management Practices	12
4.1.5 Site-Specific Borehole Installation Concerns	14
4.2 Solid Material Characterization	14
4.2.1 Waste Characterization and Piezometer Boreholes	15
4.2.2 Phase III Piezometers.....	19
4.2.3 Geotechnical Analysis Boreholes	22
4.2.4 Additional SPLP Samples.....	25
4.3 Groundwater Characterization	27
4.3.1 Water Level Measurements	29

4.3.2	Groundwater Sampling	29
4.4	Silver Bow Creek Loading Analysis.....	31
4.4.1	Flow Measurements and Surface Water Sampling.....	31
4.4.2	Data Analysis	32
4.5	Silver Bow Creek Sediment Sampling	33
4.6	Standard Operating Procedures.....	34
4.7	Documents and Records	34
4.7.1	Sample Labeling and Identification	34
4.7.2	Field Documentation.....	35
4.7.3	Sample Handling, Documentation, and Shipping.....	37
4.7.4	Chain of Custody	38
4.8	Field Analysis Methods	39
4.8.1	XRF Analysis.....	39
4.8.2	PID Screening Analysis	40
4.9	Laboratory Analysis Methods.....	40
4.9.1	Total Metals	40
4.9.2	Hydrocarbon Compounds	41
4.9.3	LNAPL Samples	41
4.9.4	Groundwater Analysis	41
4.9.5	Geotechnical Samples.....	41
4.9.6	SPLP Samples.....	41
4.9.7	Silver Bow Creek Sediment Samples	41
4.10	Quality Assurance/Quality Control Samples	42
4.10.1	Field Quality Control Samples.....	42
4.10.2	XRF Quality Control Samples	43
4.10.3	Laboratory Quality Control Samples	45
4.11	Instrument/Equipment Testing, Inspection, Maintenance and Calibration	46
4.11.1	Field Equipment.....	46
4.11.2	Lab Equipment.....	47
4.12	Inspection/Acceptance of Supplies and Consumables.....	47
4.13	Data Management Procedures	48
5.0	ASSESSMENT AND OVERSIGHT	49
5.1	Field Activities Oversight	49
5.2	Corrective Action Procedures	49
5.3	Corrective Action During Data Assessment	50
5.4	Quality Assurance Reports to Management	50
6.0	HEALTH AND SAFETY	51
7.0	PROJECT ORGANIZATION AND RESPONSIBILITIES	51
7.1.1	Subcontractors.....	52
7.1.2	Laboratory.....	53
8.0	DATA VALIDATION AND USABILITY	53
8.1	Data Review, Verification, and Validation.....	54
8.1.1	Data Review Requirements.....	54

8.1.2	Data Verification Requirements	55
8.1.3	Data Validation Requirements.....	56
8.2	Verification and Validation Methods.....	56
8.3	Reconciliation and User Requirements.....	57
9.0	REFERENCES.....	59

LIST OF FIGURES

Figure 1.	Site Location Map
Figure 2.	Site Map
Figure 3.	BRW Smelter Area Conceptual Remedial Action Plan
Figure 4.	Additional Phase III Investigation Locations to be Installed
Figure 5.	Proposed Piezometer Construction for Stickup Configuration
Figure 6.	Additional Samples for SPLP Analysis
Figure 7.	Groundwater Characterization Sampling Locations
Figure 8.	Silver Bow Creek Loading Analysis Locations
Figure 9.	Project Organizational Chart

LIST OF TABLES

Table 1.	Data Gaps Summary
Table 2.	Applicable and Relevant Standard Operating Procedures
Table 3.	Data Quality Objectives
Table 4.	Schedule
Table 5.	Precision, Accuracy and Completeness Calculation Equations
Table 6.	Sample Collection, Preservation, and Holding Times
Table 7.	Phase III Site Investigation Locations
Table 8.	Limit of Detection for XRF

LIST OF APPENDICES

Appendix A.	Standard Operating Procedures
Appendix B.	Field Forms and Tables
Appendix C.	Geotechnical Investigation Reference Documents
Appendix D.	Corrective Action Report
Appendix E.	Data Validation

ACRONYMS

Acronym	Definition	Acronym	Definition
%D	Percent Difference	MS	Matrix Spike
%R	Percent Recovery	MSD	Matrix Spike Duplicate
°C	Degree Celsius	NRDP	Natural Resource Damage Program
pCi/L	picocurie per liter	NTU	Nephelometric Turbidity Unit
ARAR	Applicable or Relevant and Appropriate Requirement	O'Keefe	O'Keefe Drilling Company
Atlantic Richfield	Atlantic Richfield Company	PARCCS	Precision, Accuracy, Representativeness, Completeness, Comparability, and Sensitivity
bgs	Below Ground Surface	PAH	Polycyclic Aromatic Hydrocarbons
BH	Borehole (for sample identification)	PCB	Polychlorinated Biphenyl
BMP	Best Management Practices	PCP	Pentachlorophenol
BNSF	Burlington Northern Santa Fe Railway	PDI	Pre-Design Investigation
BPSOU	Butte Priority Soils Operable Unit	PDS	Post Digestion Spike
BRW	Butte Reduction Works	PID	Photoionization Detector
BSB	Butte-Silver Bow	Pioneer	Pioneer Technical Services, Inc.
CAR	Corrective Action Report	PM	Project Manager
CECRA	Comprehensive Environmental Cleanup and Responsibility Act	PPE	Personal Protective Equipment
CERCLA	Comprehensive Environmental Response, Compensation, and Liability Act	PVC	Polyvinyl Chloride
CFRSSI	Clark Fork River Superfund Site Investigation	PZ	Piezometer (for sample identification)
cfs	cubic feet per second	QA	Quality Assurance
CLP	Contract Laboratory Program	QAM	Quality Assurance Manager
COC	Contaminant of Concern	QAO	Quality Assurance Officer
CPM	Contractor Project Manager	QAPP	Quality Assurance Project Plan
		QC	Quality Control
DEQ	Montana Department of Environmental Quality	RA	Remedial Action
DI	Deionized	RCRA	Resource Conservation and Recovery Act
DM/DV	Data Management/Data Validation	RD	Remedial Design
DQA	Data Quality Assessment	RDWP	Remedial Design Work Plan
		REW	Right Edge of Water
DQO	Data Quality Objective	RFC	Request for Change
EDD	Electronic Data Deliverable	RL	Reporting Limit
EPA	Environmental Protection Agency	RPD	Relative Percent Difference
EPH	Extractable Petroleum Hydrocarbon	SC	Specific Conductance
EWI	Equal Width Increment	SiO2	Silicon Dioxide
GPS	Global Positioning System	SOP	Standard Operating Procedure
Hunter	Hunter Brothers Construction	SOW	Statement of Work
ICP-MS	Inductively Coupled Plasma Mass Spectrometry	SPLP	Synthetic Precipitation Leaching Procedure
LAO	Lower Area One	SRM	Standard Reference Material
LCS	Laboratory Control Sample	SS	Sample Station
LCSD	Laboratory Control Sample Duplicate	SSHASP	Site-Specific Health and Safety Plan
LDS	Laboratory Duplicate Sample	SPT	Standard Penetration Test

Acronym	Definition	Acronym	Definition
LEW	Left Edge of Water	T	Duplicate Identification for Field Samples
LMS	Laboratory Matrix Spike	USCS	Unified Soil Classification System
LNAPL	Light Non-Aqueous Phase Liquid	USGS	US Geological Survey
MB	Method Blank	VOC	Volatile Organic Compound
MBMG	Montana Bureau of Mines and Geology	VPH	Volatile Petroleum Hydrocarbon
MPTP	Montana Pole and Treating Plant	XRF	X-Ray Fluorescence

1.0 INTRODUCTION

This site-specific Butte Reduction Works (BRW) Phase III Quality Assurance Project Plan (QAPP) (BRW Phase III QAPP) provides the procedures and protocols necessary to conduct a Phase III Site Investigation as a part of the overall remedial design (RD) effort for the BRW Smelter Area Mine Waste Remediation and Contaminated Groundwater Hydraulic Control Site (Site).

The Site is within the Butte Priority Soils Operable Unit (BPSOU) located within the city of Butte, Montana (Figure 1). The Site is located within Lower Area One (LAO), which has a history of multiple industrial uses (Figure 2). As a result, there are accumulations of slag, tailings, demolition debris, and other impacted materials that may be sources of contaminants of concern (COCs) (i.e., arsenic, cadmium, copper, mercury, lead, and zinc) and additional constituents of concern (e.g., manganese, trace elements, organic pollutants, etc.) to the underlying groundwater.

Multiple investigations have been completed at the Site, including recent investigations completed as part of the RD to fill data gaps identified by the design team (Table 1). From August 2018 through June 2021, the Phase I Site Investigation took place according to the Phase I QAPP (Atlantic Richfield Company, 2021a). Additionally, a Phase II Site Investigation began in June 2020 and concluded in March 2021 (following guidelines in a corresponding Phase II QAPP; Atlantic Richfield Company, 2021b). Based on results of the Phase I Site Investigation and preliminary results from the Phase II Site Investigation, an additional investigation is needed to fill the remaining data gaps identified in Table 1.

The Phase III Site Investigation will include additional solid material characterization, a geotechnical investigation, Silver Bow Creek sediment sampling and particle analysis, groundwater analysis during a representative range of seasonal groundwater and surface water conditions (such as high- and low-groundwater and surface water conditions), and an analysis of COCs loading to Silver Bow Creek. Since the objectives of this investigation are slightly different than previous investigations, this BRW Phase III QAPP provides new Data Quality Objectives (DQOs) specific to the Phase III Site Investigation. The DQOs were identified according to U.S. Environmental Protection Agency (EPA) *Guidance on Systematic Planning Using the Data Quality Objectives Process* (EPA, 2006).

Prior to the approval of the BRW Phase III QAPP, Agencies approved two Requests for Change (RFCs) to the BRW Phase II QAPP (RFC-BRW-2021-01 and RFC BRW-2021-02), which enabled a supplemental groundwater and surface water sampling event to occur during low-groundwater conditions. To allow the sampling event to occur during low-groundwater conditions, Agencies approved the data collection (i.e., sampling) as part of the BRW Phase II QAPP while the BRW Phase III QAPP was being finalized. However, the DQOs detailed in this BRW Phase III QAPP cover the supplemental sampling event; therefore, the data validation and interpretation associated with the supplemental sampling event will be included with the additional data collected during the Phase III Site Investigation.

1.1 Purpose of the Phase III Site Investigation

The Phase I Site Investigation included an initial data collection effort to help refine the characterization of solid materials and groundwater within the Site. That investigation took place from August 2018 through February 2020, with the exception of groundwater level measurements which continued through June 2021, and included the investigation activities detailed in the BRW Phase I QAPP and associated RFC documents (Atlantic Richfield Company, 2021a). The Phase II Site Investigation began in June 2020 and concluded in March 2021 and addressed additional design-related data gaps associated with future hydraulic control and construction dewatering and included additional data related to the characterization of solid materials, particularly slag, and groundwater within the Site (Table 1).

The Phase III Site Investigation aims to address the remaining data gaps and conclude data collection so that the design team can finalize the Site characterization and proceed with RD. Remaining design-related data gaps consist of solid materials characterization, geotechnical considerations, Silver Bow Creek realignment and sediment transport capacity, groundwater characterization, and COCs loading to Silver Bow Creek (Table 1). Additional soil data will be collected to further define the nature and extents of the COCs present within the Site, which will aid the BRW hydraulic control design and assist in determining the extent of waste removal within the removal corridor (using the waste identification criteria listed in Table 1 in Appendix 1 of Attachment C of Appendix D of the BPSOU Consent Decree [CD] [EPA, 2020a]). A geotechnical investigation will characterize the geotechnical properties of subsurface materials to remain in place in areas of potential structural features that will be constructed as part of the Site's end land use. The geotechnical investigation will also gather data to supplement the excavation surface design to ensure stable slopes adjacent to existing features on and off the Site. Sediment samples collected from Silver Bow Creek will be analyzed to determine sediment particle size distribution, which will be used to calculate the required sediment transport capacity through the Site to assist in designing the realigned Silver Bow Creek and 100-year floodplain. Finally, a primary goal of the Phase III Site Investigation is to assess the effects of a range of seasonal groundwater and surface water conditions. The chemical and spatial variability of groundwater within the Site, as well as the COCs loading to Silver Bow Creek, will aid in optimizing and designing the realigned Silver Bow Creek and BRW hydraulic control.

To support the Phase III Site Investigation, this document includes the following information:

1. Site Background (Section 2.0).
2. DQOs (Section 3.0).
3. Sampling Process and Design (Section 4.0).
4. Assessment and Oversight (Section 5.0).
5. Health and Safety (Section 6.0).
6. Project Organization and Responsibilities (Section 7.0).
7. Data Validation and Usability (Section 8.0).

This document references Pioneer Technical Services, Inc. (Pioneer) Standard Operating Procedures (SOPs) for activities that outline specific procedures to safely complete tasks included in the Phase III Site Investigation. Table 2 lists the applicable SOPs.

1.2 Objectives of the Phase III Site Investigation

The main purpose of the Phase III Site Investigation is to collect additional data to support the RD for the Site. The conceptual RD is shown on Figure 3. The specific objectives of the investigation include the following:

- **Additional Solid Material Characterization:**
 - Collect additional information to refine the volume and location of waste materials within the removal corridor and obtain additional information on the chemical stability/leachability of solid materials to integrate the waste removal design with the effectiveness of the hydraulic control.
 - Collect additional information to refine the extents of the soil impacted with organic pollutants and the concentrations of organic pollutants within the soil to help define appropriate Site-specific action levels and develop the proper management plan for soil impacted with organic pollutants both inside and outside the removal corridor.
- **Geotechnical Investigation:** Collect data regarding the physical properties of the soil within the Site to inform the designs of structural features planned as part of the end land use and the design of the excavation surface.
- **Silver Bow Creek Sediment Sampling:** Collect data representing the stream sediment particle size distribution along the current alignment of Silver Bow Creek to guide the design of the realigned Silver Bow Creek.
- **Groundwater Characterization:** To guide the designs for the BRW hydraulic control and realigned Silver Bow Creek and collect additional physical and chemical data at specific locations during a representative range of seasonal groundwater and surface water conditions, such as low- and high-groundwater and surface water conditions, to provide finer detail on the nature and extent of COC-impacted groundwater in addition to groundwater impacted with organic pollutants (hydrocarbon compounds, polychlorinated biphenyl [PCB], pentachlorophenol [PCP], and/or dioxins) within the Site. An additional objective is to establish a baseline for groundwater conditions (hydraulic gradient and chemistry) between the Montana Pole and Treating Plant (MPTP) site and the Site to inform the design of the future BRW hydraulic control and/or construction dewatering efforts that will take place during the Remedial Action (RA). The new piezometers to be installed, along with the existing piezometer and monitoring wells, will help establish an “early detection network.” The “early detection network” will monitor water levels and PCP concentrations to ensure that the hydraulic gradient between the MPTP Site and the Site does not significantly change and that notable concentrations of PCP do not migrate during construction dewatering and/or as a result of implementing the BRW hydraulic control.
- **Silver Bow Creek Loading Analysis:** Collect additional information needed to determine the nature, extent, and source of the COCs loading to Silver Bow Creek from the area

between sample station (SS) SS-05B and SS-06A (Figure 2) during a representative range of seasonal groundwater and surface water conditions, such as low- and high-groundwater and surface water conditions.

To meet the objectives above, the following activities will be completed as part of the Phase III Site Investigation:

- Continue to collect solid material data to further define the nature and extent of the COCs and organic pollutants within the Site. This will aid the BRW hydraulic control design, help determine the appropriate waste removal depth within the removal corridor for the RA, and help develop a management plan for the soil within the Site impacted by organic pollutants including development of Site-specific action levels.
 - Drill the Waste Characterization Boreholes at identified data gap locations, collect soil samples from lithological layers, and analyze for COCs, hydrocarbon compounds, and chemical stability/leachability. The analyses will be used to determine the extent of waste material within the removal corridor, to inform the BRW hydraulic control design, and to help develop a management plan for the soil impacted with organic pollutants above Site-specific action levels within the Site.
 - Drill the Phase III Piezometers at the identified locations, collect soil samples from lithological layers, and analyze for COCs, hydrocarbon compounds, and chemical stability/leachability. The analyses will be used to inform the hydraulic control design and to help develop a management plan for the soil impacted with organic pollutants above Site-specific action levels within the Site.
 - Collect samples from soil cores that were retrieved from the Site during the Phase I Site Investigation activities and archived at the Pioneer field office at 244 Anaconda Road in Butte, Montana. Analyze the samples for COCs and chemical stability/leachability. These analyses will be used to refine the estimate of chemical leachability of slag within the Site and the extents of a potential highly leachable soil layer near piezometer BRW18-PZ08 (Figure 4).
- Complete a geotechnical analysis of Site conditions and soil that will be encountered during RA activities and that may remain in place after the RA is complete. The data and construction recommendations obtained will support the excavation design and future Site design, which is expected to include a parking lot, walking trails, a potential amphitheater¹, support utilities, and other infrastructure.
 - Drill boreholes at select locations identified based on the conceptual removal corridor and preliminary end land use design. Additional boreholes may be required once the Intermediate 60% RD documents are reviewed by Agencies as the design will include details regarding the end land use plan. If additional boreholes are required, an RFC to this QAPP will be submitted for Agency review and approval prior to completing the additional boreholes.

¹ Design, construction, and operation and maintenance of the amphitheater requires mutual agreement of Atlantic Richfield Company and Butte-Silver Bow, and identification and commitment of a third-party investor and operator.

- Complete Standard Penetration Tests (SPTs) and collect soil samples, possibly including Shelby tube samples, for specified analysis from each borehole.
- Collect Silver Bow Creek sediment samples for particle size distribution near the upstream and downstream tie in locations of the realigned stream and 100-year floodplain. The sediment sample particle size distribution will support the stream design.
- Collect groundwater data during a representative range of seasonal groundwater and surface water conditions, such as high- and low-groundwater and surface water conditions, to further define the characterization of groundwater and aid in the optimization and design of the BRW hydraulic control.
 - Install the Phase III Piezometers, collect groundwater samples, then analyze the samples for specified analytes to establish a baseline for groundwater conditions (i.e., chemistry and hydraulic gradient) between the MPTP Site and the Site. Groundwater conditions between the MPTP Site and the Site will be monitored to avoid migration of organic pollutants during construction dewatering and/or as a result of implementing the BRW hydraulic control.
 - Collect groundwater samples from existing monitoring wells and piezometers during a representative range of seasonal groundwater and surface water conditions, then analyze for specified analytes to further define the nature and extent of the areas within the groundwater aquifer within the Site that have been impacted with dissolved COCs and organic pollutants (hydrocarbon compounds, PCBs, PCP, and dioxins).
 - Continue to collect groundwater and surface water level data to observe seasonal elevation changes and possible direction of flow changes.
- Complete a loading analysis for Silver Bow Creek from the area between SS-05B and SS-06A (Figure 2) during a representative range of seasonal groundwater and surface water conditions, such as high- and low-groundwater and surface water conditions, to aid the BRW hydraulic control design.
 - Collect groundwater and surface water samples from existing monitoring wells / piezometers and staff gages, respectively, and analyze for specified analytes to determine changes in chemical concentration and loading to Silver Bow Creek during a representative range of seasonal groundwater and surface water conditions.

2.0 BACKGROUND

Details of the Site, its history, and previous investigations are included in the BRW RD Work Plan (RDWP) (Atlantic Richfield Company, 2021c) and the corresponding Pre-Design Investigation (PDI) Work Plan included as an attachment to the RDWP. These documents are working documents and will be updated as needed. Summaries relevant to the Phase III Site Investigation are included in the sections below.

2.1 Site Description

The Site is in Butte, Montana, covers approximately 24 acres, and is located immediately west of Montana Street between Silver Bow Creek and the Burlington Northern Santa Fe (BNSF)

Railway line (Figure 1 and Figure 2). Currently, Butte-Silver Bow uses the Site to store materials.

The Site is located within an urban area and adjacent to other impacted areas. To the south and west of the Site, the MPTP Site (Figure 2) treats extracted groundwater impacted by nearly 40 years of uncontrolled releases of a solution of approximately 5% PCP mixed with a petroleum carrier oil that was used to preserve poles, posts, and bridge timbers from 1946 to 1984 (EPA, 2017). NorthWestern Energy (NWE) has a storage yard and operating center immediately south of the Site (Figure 2). The storage yard has been there since 1899 and is a Comprehensive Environmental Cleanup and Responsibility Act (CECRA) site. Underground storage tanks and on-site use or disposal of various substances such as paints, solvents, mercury, Fuller's earth, wood-treating compounds, and transformer oil containing PCBs have resulted in on-site soil contamination and possibly localized groundwater contamination (DEQ, 2002).

2.2 Site History

Beginning in 1885 to the time of this writing, the Site has been the location of multiple industrial operations including a copper smelter and a zinc concentrator, and it was also used by the Domestic Manganese and Development Company (Sanborn, 1943) and Rocky Mountain Phosphates, Inc. (GCM Services, Inc., 1991). This complex history of activities has resulted in a complex distribution of materials within the Site (including slag, tailings, manganese waste, demolition debris, foundations, and other historic structures) as well as impacted soil and groundwater (Atlantic Richfield Company, 2021c).

2.3 Relevant Previous Investigations

2.3.1 Preliminary Results from Phase I Site Investigation

The Phase I Site Investigation began in 2018 and concluded in 2020, with the exception of groundwater level measurements which continued through June 2021. The PDI Evaluation Report (Atlantic Richfield Company, 2021d) listed results from field activities conducted as specified in the BRW Phase I QAPP (Atlantic Richfield Company, 2021a). The PDI Evaluation Report identified remaining data gaps to be addressed in Phase II and Phase III Site Investigations. The report called for the installation of five additional boreholes, referred to as the Waste Characterization Boreholes, to collect the remaining data needed to identify the waste material within the Site (defined by the BPSOU CD Waste Identification Screening Criteria [EPA, 2020a]). Using Leapfrog Works, a geological modeling software, locations were found where additional data would refine waste volumes. The PDI Evaluation Report also highlighted the need for a geotechnical analysis.

Additionally, Atlantic Richfield Company (Atlantic Richfield) has identified the need to collect additional samples for Synthetic Precipitation Leaching Procedure (SPLP) analysis based on the sample results from the Phase I Site Investigation (Atlantic Richfield Company, 2021d). These additional samples are necessary to refine the estimated chemical leachability of slag within the Site and refine the extents of a potential highly leachable soil layer near piezometer BRW18-PZ08 (Figure 4).

2.3.2 Preliminary Results from Phase II Site Investigation

The Phase II Site Investigation, which began in March 2020 and concluded in March 2021, focused on collecting additional design data related to the groundwater and aquifer within the Site. The Site activities and data collection for the Phase II Site Investigation are detailed in the BRW Phase II QAPP (Atlantic Richfield Company, 2021b). Once site investigation activities are complete, including data validation, the results from the Phase II Site Investigation will be incorporated into the PDI Evaluation Report and submitted for Agencies review.

2.4 BRW Remedial Action

The BRW RA will include removing tailings, waste, COC-impacted soil, and slag within the Silver Bow Creek 100-year floodplain reconstruction area to a depth to be determined during the RD activities. The conceptual RD, shown on Figure 3, will include the following elements:

- Waste removal (as defined by the BPSOU CD Waste Identification Screening Criteria [EPA, 2020a]) from the Site in a corridor that will contain a new channel for Silver Bow Creek to a depth determined during the RD.
- Management of soil and groundwater within the Site impacted by organic pollutants, as appropriate, and in a manner that is complementary with the remedy. Organic pollutants (hydrocarbon compounds, PCBs, PCPs, and dioxins) are secondary concerns for the Site. Soil and groundwater within the Site that have been impacted by these pollutants above Site-specific action levels will be addressed/managed as necessary to implement the remedy, but the long-term management and remediation of soil and groundwater impacted with organic pollutants (i.e., treatment of organic pollutant sources) is not required by the BPSOU CD.
- Realign Silver Bow Creek and construct the bank-full channel and 100-year floodplain.
- Regrade and construct caps over the tailings, waste, impacted soil, and slag left in place.
- Hydraulically manage COC-impacted groundwater at the Site to control discharge of COC-impacted groundwater to surface water and sediment in the BPSOU generally and within the Site specifically.

All COC-impacted soil and slag will be removed within a corridor having an average width of 275 feet from the toe of the BNSF Railway embankment extending north (Figure 3). The removal corridor will include the alignment of Silver Bow Creek and the 100-year floodplain. Areas where slag and COC-impacted soil are left in place will be appropriately capped to ensure protectiveness of human health and surface water. The entire Site will be regraded to produce a land surface that will facilitate future end land uses and account for geotechnical considerations related to constructing future structures.

To remove material from the Site, heavy construction equipment will need to travel on the material at the bottom of the excavation safely and effectively. Initial reconnaissance suggests that most of the area within the removal area boundary may require at least nominal construction dewatering while deeper portions of the area may require that the water table be lowered up to

16.5 feet below the current water table elevation (a maximum of approximately 14.5 feet to bottom of waste, plus an additional 2 feet is anticipated for safe equipment access) (Atlantic Richfield Company, 2021e).

As part of the RA, COC-impacted groundwater from the Site must be hydraulically managed to control COC-impacted groundwater discharge to the newly constructed and existing portions of Silver Bow Creek that would lead to violations of surface water Applicable or Relevant and Appropriate Requirements (ARARs) for the BPSOU, to prevent degradation of groundwater that exceeds current standards, and to comply with the Surface Water Management Plan (EPA, 2020a).

3.0 DATA QUALITY OBJECTIVES

The DQOs are statements that define the type, quality, quantity, purpose, and use of data to be collected. EPA developed a seven-step process for establishing DQOs to help ensure that data collected during a field sampling program will be adequate to support reliable site-specific decision making or estimation, whichever is appropriate (EPA, 2006). The following DQOs were developed for the Phase III Site Investigation according to the EPA process. The DQOs are also detailed in Table 3:

- Solid Material Characterization.
- Geotechnical Investigation.
- Silver Bow Creek Sediment Sampling.
- Groundwater Characterization.
- Silver Bow Creek Loading Analysis.

The project schedule is included as Table 4.

3.1 Measurement Performance Criteria for Data

Specific data validation processes ensure that analytical results are within acceptable limits. For work completed under this BRW Phase III QAPP, all data gathered will be checked to ensure they are usable for their intended purposes. Analytical control limits and the precision, accuracy, representativeness, completeness, comparability, and sensitivity (PARCCS) parameters of the data will be analyzed. If significant issues with any data are found, results will be discussed with EPA and Montana Department of Environmental Quality (DEQ) project managers. EPA, in consultation with Montana DEQ, will then decide if the total study error could cause them to make an incorrect decision. Using this approach, the probability of making an incorrect decision (i.e., either a false negative or positive) based on the information collected is considered small.

The PARCCS definitions are provided below along with the acceptance criteria for data collected. Equations for calculating precision, accuracy, and completeness are provided in Table 5.

Precision

Precision is the amount of scatter or variance that occurs in repeated measurements of a particular analyte. Acceptance or rejection of precision measurements is based on the relative percent difference (RPD) of the laboratory and field duplicates. For example, perfect precision would be a 0 percent RPD between duplicate samples (both samples have the same analytical result). For groundwater samples, the control limit of a RPD less than 20 percent will be used when sample results are greater than 5 times the laboratory Reporting Limit (RL). If either of the sample results are less than 5 times the RL, the control limit used will be a difference between sample results less than the RL. For soil samples, the control limit of an RPD less than 35 percent will be used when sample results are greater than 5 times the RL. If either of the sample results are less than 5 times the RL, the control limit used will be a difference between sample results less than 2 times the RL. This precision requirement is derived from the *Clark Fork River Superfund Site Investigation (CFRSSI), Laboratory Analytical Protocol (ARCO, 1992a)*, the National Functional Guidelines for Inorganic Superfund Methods Data Review (EPA, 2020b), and the *CFRSSI QAPP (ARCO, 1992b)*.

Accuracy

Accuracy is the ability of the analytical procedure to determine the actual or known quantity of a particular substance in a sample. Accuracy is assessed based on the percent recovery (%R) and percent difference (%D) of various laboratory quality control (QC) samples. Perfect %R is 100% and perfect %D is 0% (the analysis result is exactly the known concentration of the QC sample). The laboratory control sample (LCS) and laboratory matrix spike (LMS) are used to measure accuracy, based on the %R of the LMS and LCS. An acceptable accuracy range for the %R of LMS and LCS is 80% to 120% in groundwater samples and 75% to 125% for soil samples. Additional laboratory QC samples may be used to assess accuracy as appropriate to the analytical method. Accuracy requirements for this project are derived from the CFRSSI QAPP (ARCO, 1992b).

Representativeness

Representativeness is a qualitative parameter that is addressed through proper design of the sampling program. The sampling program is designed to obtain a sufficient number of samples that adequately represents the range of conditions present in the medium being sampled and specify suitable sampling methods and procedures.

For this Phase III Investigation, the Contractor Project Manager (CPM) will review the BRW Phase III QAPP to ensure that it is designed to collect the data and information necessary to meet the purpose of the investigation. The review will consider the volume, variability, and intended use of the data to ensure proper sampling methods and adequate spatial distribution of samples.

After the data have been collected and analyzed, the Field Team Leader or CPM will review the data and qualitatively assess whether the data adequately represent the Site conditions and intended purpose of the investigation. Sample representativeness may also be evaluated using the RPDs for field duplicate sample results, if applicable.

Completeness

Completeness determines if enough valid data have been collected to meet the investigation needs. Completeness is assessed by comparing the number of valid sample results to the number of sample results planned for the investigation. Although not all the analytes measured in this sampling effort have completeness objectives outlined in the CFRSSI QAPP (ARCO, 1992b), the completeness target for this investigation is 95.0% or greater as designated in the CFRSSI QAPP.

Comparability

Comparability determines if one set of data can be compared to another set of data. Comparability will be assessed by determining if an EPA-approved analysis method was used, if values and units are sufficient for the database, if specific sampling points can be established and documented, and if field collection methods are similar. All SOPs for this investigation are included in Appendix A. Analysis methods for each analytical group are listed in Table 6. The applicable analytical group for each sampling location is listed in Table 7.

Completeness

Completeness determines if enough valid data have been collected to meet the investigation needs. Completeness is assessed by comparing the number of valid sample results to the number of sample results planned for the investigation. Although not all the analytes measured in this sampling effort have completeness objectives outlined in the CFRSSI QAPP (ARCO, 1992b), the completeness target for this investigation is 95.0% or greater as designated in the CFRSSI QAPP.

Method Sensitivity

Method sensitivity is related to the method detection limits. The method sensitivity or lower limit of detection depends on several factors, including the analyte of interest, the method used, the type of detector used, matrix effects, etc. Appropriate methods must be selected with sufficient method sensitivity to accomplish the project's goals. Two methods are listed below.

X-Ray Fluorescence (XRF) Analysis: The method sensitivity or lower limit of detection for XRF analysis depends on several factors, including the analyte of interest, the type of detector used, the type of excitation source, the strength of the excitation source, count times used to irradiate the sample, physical matrix effects, chemical matrix effects, and interelement spectral interferences. Example lower limits of detection for analytes of interest in environmental applications are listed in Table 8. These limits apply to a clean, spiked matrix of quartz sand (silicon dioxide) free of interelement-spectral interferences using long (100 - 600 second) count times. These sensitivity values are given for guidance only and may not always be achievable, because they will vary depending on the sample matrix, which instrument is used, and operating conditions.

Modern Water RaPID Assay PCP Screening Kit (PCP Screening Kit): The method sensitivity or lower limit of detection for the PCP Screening Kit is 0.1 parts per billion for water samples. Also, the PCP Screening Kit does not differentiate between PCP and other organochlorines. Therefore, laboratory samples will also be collected and analyzed for PCP and other organochlorines to evaluate any cross reactivity.

Laboratory Analysis: The method sensitivity for laboratory analyses is determined as part of the laboratory's SOPs. The laboratory RL for each analyte is listed in Table 6. These detection limits will be reviewed as part of the data validation process (Section 8.0).

4.0 SAMPLING PROCESS AND DESIGN

The Phase III Site Investigation will include soil sampling, a geotechnical investigation, groundwater sampling, a COC loading analysis, and sediment sampling along Silver Bow Creek during a representative range of seasonal groundwater and surface water conditions, such as high- and low-groundwater and surface water conditions. The following subsections provide the procedures and protocols necessary to complete these tasks.

4.1 Preparation for Fieldwork

The following tasks will be completed prior to conducting field activities.

4.1.1 Training

All field personnel will have a current certification for the 40-hour Occupational Safety and Health Administration Hazardous Waste Site and Emergency Response Training. Current certification records will be maintained at Pioneer's headquarters at 1101 S. Montana Street in Butte, Montana.

In a project meeting held prior to fieldwork, all field personnel will review this BRW Phase III QAPP and receive any specified training. Field personnel will review sampling and monitoring procedures and requirements prior to field activities to ensure collecting and handling methods are completed according to the BRW Phase III QAPP requirements. Field personnel will be trained in how to properly use field equipment and complete activities according to field data collection SOPs in Appendix A.

The Field Team Leader will review the internal BRW Site-Specific Health and Safety Plan (SSHASP) with all field personnel prior to fieldwork to assess the Site's specific hazards and the control measurements put in place to mitigate these hazards. The BRW SSHASP review will cover all other safety aspects related to the Site including personnel responsibilities and contact information, additional safety requirements and procedures, and the emergency response plan.

The Field Team Leader will be responsible for training field personnel on how to calibrate field measurement instruments. The Field Team Leader will be experienced in the use and calibration of the equipment that will be used and responsible for training and overseeing the support staff. One hard copy of the current approved version of the BRW Phase III QAPP will be maintained for reference purposes in the field vehicle and/or field office. All field team personnel will have access to electronic PDF format files of all documents pertaining to fieldwork.

4.1.2 Property Access

Atlantic Richfield, BNSF Railway Line, Montana DEQ, and NWE own the property where the field activities will be performed. Atlantic Richfield currently has an access agreement with NWE to sample monitoring well MW-03-MPC and an access agreement with Montana DEQ to sample monitoring wells MW-O-01 and MW-I-96 on the MPTP Site. Atlantic Richfield is in the process of obtaining a property access agreement with BNSF Railway Line to sample monitoring wells GW-13 and GW-17. Copies of the access agreements will be placed in the field binder to have on hand during the field activities.

Atlantic Richfield is currently completing the process to gain access to the BNSF property; however, it is anticipated that this process may take months based on communication with BNSF and may not be timely for the groundwater sampling event. Montana DEQ has offered to sample the wells on behalf of Atlantic Richfield. As part of the 1996 CD for the MPTP Site (information available on the Montana DEQ Superfund site at <https://deq.mt.gov/cleanupandrec/Programs/superfundfed>), EPA and DEQ (and EPA and DEQ contractors) have access at all reasonable times to the MPTP Site and any other property to which access is required for implementing the MPTP CD, which includes monitoring wells GW-13 and GW-17. DEQ views the data collected from GW-13 and GW-17 as mutually beneficial to both DEQ and Atlantic Richfield. Particularly, DEQ agrees with Atlantic Richfield that data are needed to establish a baseline of groundwater conditions between the BRW Site and the MPTP Site to avoid any potential impacts to the MPTP Site groundwater remedy by future remedial activities at the BRW Site, such as construction dewatering and hydraulic control.

In the event that Atlantic Richfield is unable to obtain access to the BNSF property in a timely manner, Tetra Tech (Tom Bowler), contractor and representative to DEQ, will collect the groundwater samples from monitoring wells GW-17 and GW-13 following the protocols and procedures identified in this QAPP. Mr. Bowler will collect the samples and then hand them over to Atlantic Richfield to submit to the laboratory for analyses.

4.1.3 Utility Locates

There is a possibility that investigation points could shift once underground utilities are located throughout the Site. Utility locates will be performed prior to any fieldwork and will follow BP Remediation Management Defined Procedures for ground disturbance in addition to applicable control measures addressed in the internal BRW SSHASP. Final utility locates for the work area will be completed by the performing authority prior to any ground disturbance activities.

4.1.4 Best Management Practices

Although a Joint Application for Proposed Work in Montana's Streams, Wetlands, Floodplains, and other Water Bodies (Joint Application) is not required for Superfund related activities, Atlantic Richfield has identified measures that will be taken to ensure that the substantive requirements of the Joint Application and applicable requirements are met during the field activities. Protection of the environment during field activities will be addressed through implementation of short-term construction Best Management Practices (BMPs). General

descriptions of the BMPs to be implemented to minimize the project impacts to the floodplain/wetland area within the Site are provided in the sections below.

4.1.4.1 Minimize Project Impacts to Floodplain/Wetland

During the Phase III Site Investigation, work may be performed within the floodplain/wetland area on the west side of the Site. Specifics of the work activities are detailed below and throughout this document. To minimize project impacts to the floodplain/wetland area, the following measures will be taken:

- The access road used to access the floodplain/wetland area and the drill pad were installed during the Phase II Investigation and were designed to limit the amount of disturbance in the floodplain/wetland area.
- Equipment must stay on the access road or drill pad while work is completed in the floodplain/wetland area, except for the Geoprobe® unit, which will be used to install piezometers and drill boreholes within the floodplain/wetland area.
- Material and supplies will be transported to and stored on the drill pad in appropriate containers. No hazardous materials or liquids will be stored on the drill pad and/or within the floodplain/wetland area.

4.1.4.2 In-Stream Turbidity Control

During the Phase III Site Investigation, some work must be performed within close proximity to the stream channel under flowing conditions with the potential to release sediments into the active watercourse. This work includes drilling boreholes within close proximity to the stream. The following construction BMPs will be implemented for work along Silver Bow Creek to reduce sediment loading and excessive turbidity:

- Geoprobe work will be set back from Silver Bow Creek to provide a protective vegetative buffer between the Geoprobe unit and the Silver Bow Creek channel.
- If the Geoprobe unit must work in close proximity to the stream channel, it will be required to track perpendicularly to the streambank to prevent bank collapse or damage, prevent excessive impact to existing vegetation, and prevent equipment falling into the stream.
- The Geoprobe unit will not be allowed to enter the active stream channel.

4.1.4.3 Stormwater Management

During Site work activities, standard BMPs will be followed/installed, as appropriate, to minimize off-Site sediment tracking and to prevent stormwater runoff from transporting sediments and/or pollutants (e.g., construction related oils, fuels, and other materials)

downgradient into Silver Bow Creek. These BMPs may include, but are not limited to, the following:

- A vegetative buffer of native soil/vegetation will help attenuate any sediments and/or pollutants in stormwater flowing from the access road and drill pad to Silver Bow Creek.
- Spillguard® secondary containment systems (or equivalent) will be used, as necessary, to contain any inadvertent spills or leaks.
- Sediment cores from every borehole drilled during this project will be stored in their entirety (in increments) at the Pioneer field office at 244 Anaconda Road in Butte, Montana, or an alternate suitable location.
- Sediments, drill cuttings, materials from potholing, etc. that are not sent to a laboratory will be stockpiled on the Site for disposal during the RA, disposal at the Mine Waste Repository, or other viable option at the discretion of the CPM.
- Development water will be transported to a holding tank and sampled for hydrocarbon compounds prior to management/disposal. The need for management/disposal options, if necessary, will be determined based on the laboratory results.
- General good housekeeping practices.

The Field Team Leader will be responsible for ensuring BMPs are installed properly at appropriate locations. Additionally, the Field Team Leader will be responsible for initiating corrective actions, as necessary.

4.1.5 Site-Specific Borehole Installation Concerns

Past drilling and probing at the Site found heaving sands to be a concern. Therefore, potable water may be added to the drill and/or probe strings as they are advanced to prevent formation heave inside the drill and/or probe rod. The added water provides a positive pressure inside the sample string, minimizing the amount of water and soil invading the drill and/or probe rod as the core sample is retrieved. Water will be added only when needed and not on a routine basis.

Additionally, depending on the drilling conditions, water may be added to help the drill rig progress through tougher material (i.e., slag and demolition debris). Any recovered water will be contained within a specified containment area. Based on field observations, if the recovered water appears to contain hydrocarbon compounds, the recovered water will be sampled for hydrocarbon compounds prior to management/disposal. The need for management/disposal options, if necessary, will be determined based on the laboratory results.

4.2 Solid Material Characterization

Up to 19 boreholes will be drilled as part of the solid material characterization component of the Phase III Site Investigation (Figure 4).

- Waste Characterization Boreholes: Up to 5 boreholes will be drilled and sampled to fill the data gaps related to the distribution of waste materials within the Site. These 5 locations were identified during the evaluation of data from the Phase I Site Investigation.

Additional details are in the PDI Evaluation Report (Atlantic Richfield Company, 2021d).

- Phase III Piezometers: 2 additional boreholes will be drilled (and piezometers installed) as part of the baseline monitoring and early detection system that will be located between the Site and the MPTP Site (Figure 4).
- Geotech Analysis Boreholes: 12 boreholes will be drilled as part of the geotechnical investigation. *In-situ* field tests will be conducted to determine the strength of the soil at 5-foot interval depths and soil samples will be collected from the boreholes and analyzed for geotechnical properties listed in Table 6 (Analytical Group 14). This information will be used to fill the data gaps related to designing the excavation surface and end land use features.

The number and location of the boreholes may be modified as determined by the Field Team Leader and/or CPM in consultation with the Contractor Quality Assurance Officer (QAO) (Section 7.0). Drilling and sampling are to be conducted as per all relevant and applicable SOPs in Appendix A. Specific to this investigation, certain modifications to the SOP are provided in this section.

4.2.1 Waste Characterization and Piezometer Boreholes

4.2.1.1 Drilling Equipment

It is anticipated that the collection of high-quality core samples will be accomplished by either a sonic drilling rig or Geoprobe unit, as appropriate. Only the Geoprobe unit will be used to drill the boreholes in the floodplain. Core samples will be examined to produce a detailed lithologic characterization log of the subsurface materials at each borehole location. The following paragraphs include output details and general practices for each instrument.

Sonic Drilling Rig

The sonic drilling rig will provide continuous core samples, which are anticipated to be 5 feet in length by 4 inches in diameter. To temporarily store the sediment core, polyethylene sleeves designed to fit over the core barrels will be used. Each 5-foot length will be properly labeled to split the core into manageable units for storage.

Geoprobe

The Geoprobe unit will provide continuous core samples using the dual tube soil sampling system. These core samples are anticipated to be up to 5 feet in length by 2 inches in diameter. To temporarily store the sediment core from the Geoprobe unit, plastic liners will be used within the inner core barrel to collect the core samples. Each 5-foot length will be properly labeled for storage.

4.2.1.2 General Procedures

The following general procedures will be performed at each proposed Waste Characterization Borehole and proposed Phase III Piezometer location identified in Table 7. Note that this list is not intended to be a complete list.

- Prepare drill equipment for operation. This includes, but is not limited to, decontaminating drilling tools and sampling equipment, leveling the rig, preparing the down-hole tool, and establishing the drill location.
- Begin advancing the core barrel. Advance the core barrel to collect the core sample, then retrieve the inner core barrel to recover the core sample.
- Classification and lithology of the core from each borehole will be logged and sampled following the general procedures listed below.
- Continue adding core barrel segments and collecting core samples until desired depth has been reached.
- Decontaminate the drill rig core barrel(s) between samples by rinsing with tap water and/or using a high-pressure washer.
- Backfill Waste Characterization Boreholes with bentonite hole plug.
- Record location of each borehole with the Global Positioning System (GPS) unit and/or survey.

The general depth of each borehole is specified in Table 7 and may be limited or increased based on field personnel observations.

Equipment

Equipment used to collect core samples will include, but not be limited to, the following:

- Field logbook and pens.
- Measuring tape.
- Unified Soil Classification System (USCS) chart (ASTM D-2488) (Appendix B).
- Munsell color chart (Munsell, 2009).
- Field XRF unit.
- Sieve.
- Portable heater or oven.
- Two photoionization detectors (PIDs) (9.8 eV and 10.6 eV lamps) with humidity filter.
- Sample containers and labels.
- Chain of custody forms.
- Coolers.

- Decontamination equipment (pressure washer, tap water, dilute nitric acid, liquinox soap, decontamination containers, paper towels, scrub brushes, and spray bottles) (refer to SOP-DE-02 in Appendix A).
- Camera and film, digital camera, and/or digital video camera.
- Survey-grade GPS unit.
- Appropriate safety personal protective equipment (PPE).

Logging

The classification and lithology of the core will be logged and photographed. This will include a soil log of the borehole that lists USCS classification (Appendix B); visual estimate of rock content (2-inch plus fraction); angularity of the grains (when feasible); color (as per Munsell color chart [Munsell, 2009]); depth to top and bottom of each stratigraphic unit; presence or absence of soil staining, odors, nodules, organic matter, and/or groundwater; percent recovery; type of drilling equipment; and bedrock depth (if encountered). All relevant observations will be recorded in a bound field logbook or on the designated field form (Appendix B).

PID Screening Analysis

Prior to drilling each borehole, visual observations (sight and/or smell) and a PID will be used to identify sources of hydrocarbon compounds on the surface. Any findings will be recorded in the field logbook. The procedures for using the PID are detailed in Section 4.8.2. If the presence of hydrocarbon compounds is detected (via sight and/or smell or detection with a PID) on the surface, a surface sample may be collected for hydrocarbon analyses as determined by the Field Team Leader.

Sampling and Analysis Procedures

Core samples will be collected from the Waste Characterization Boreholes and Phase III Piezometer locations shown on Figure 4 using a sonic drilling rig or Geoprobe® unit. Core samples will be collected according to all applicable SOPs in Appendix A. Soil samples will be collected at the locations listed in Table 7 and analyzed for analytes specified in Table 6. The required samples for each location are identified in the “Solid Material Characterization (Analytical Group From Table 6)” column in Table 7 and correspond to the “Analytical Group” identified in Table 6.

The following general procedures will be performed at each location (at the depth intervals). Note that this is not intended to be a complete list.

1. Prior to use, and between samples, wash all utensils with a detergent solution, followed by a tap water rinse, a diluted acid rinse (if necessary), and a final rinse with deionized (DI) water.
2. Open the core sleeve and lay out the core samples in order on strips of visqueen or other appropriate material where the boring depth footage has been pre-labeled.
3. Split any non-slag material within the core lengthwise using a plastic spatula and/or stainless-steel blades.

4. Use two PIDs to immediately screen for any hydrocarbon compounds (Section 4.8.2). If the presence of hydrocarbon compounds is detected (via sight, smell, and/or detection with a PID), complete the following:
 - Confirm all visual and olfactory observations of suspected hydrocarbon compounds with a PID prior to collecting a sample.
 - Immediately collect samples for headspace detection method (Section 4.8.2) and laboratory hydrocarbon analyses (Table 6).
 - A soil sample may be collected near the top of the saturated layer (in the capillary fringe) for hydrocarbon analyses (Table 6 and Table 7) if determined necessary by the Field Team Leader or CPM.
5. Photograph the complete length of the core in 2-foot segments from directly overhead using parallel camera movement and a high-resolution setting.
 - Take additional photographs of subsamples for documentation, as necessary.
6. Conduct field XRF analysis for specified analytes for each material horizon via the XRF unit, unless determined otherwise by field personnel. The field XRF analysis results will be used to estimate the first lithological layer in each boring that passes the Waste Identification Screening Criteria (EPA, 2020a).
 - Based on the field XRF analyses, up to two samples will be collected for each borehole and submitted for Synthetic Precipitation Leaching Procedure (SPLP) analysis, unless determined otherwise by field personnel. Samples will be collected from up to two distinct lithological layers with field XRF analysis values of COC concentrations that suggest notable concentrations of leachable COCs as determined by the CPM and Contractor QAO. At the discretion of the CPM and Contractor QAO, the analytical approach may be altered based on field observations or analytical results. Agency personnel will be notified prior to implementing a new analytical approach.
 - A sample will be collected from each lithological layer in each boring and submitted for metals analysis via inductively coupled plasma mass spectrometry (ICP-MS) (Table 6), unless the lithological layer is too thin and there is not enough soil to fulfill the required sample volume. In this instance, a sample will be collected and prepped for official XRF analysis (Section 4.8.1).
 - Samples will be collected as per SOP-S-12 or SOP-S-13 included in Appendix A.
7. Place the core samples in properly labeled sample core boxes for transport (the labels will include location, depth interval, and core orientation). It is imperative that the core sample is marked clearly and is carefully transported horizontally, as it will be used for further observation, sample selection, and analysis.

Sediment cores from every borehole drilled during this project will be stored in their entirety (in increments) at the Pioneer field office at 244 Anaconda Road in Butte, Montana, or an alternate suitable location. When it has been determined that enough sample is present for design-related purposes, additional samples will be shared with other parties, transferred from Pioneer's field

office, or disposed of appropriately. Sediments, drill cuttings, materials from potholing, etc. that are not sent to a laboratory will be stockpiled on the Site for disposal during the RA, disposal at the Mine Waste Repository, or other viable option at the discretion of the CPM.

4.2.2 Phase III Piezometers

The field team will install 2 additional piezometers to determine the baseline groundwater conditions between the Site and MPTP Site (Figure 4 and Table 7). The number and location of the piezometers may be modified as determined by the Field Team Leader and/or CPM in consultation with the Contractor QAO. Field personnel will record survey-grade GPS location coordinates for all piezometer locations.

4.2.2.1 Installing Piezometers

Piezometers will be installed as best suits the field conditions.

All piezometers will be installed in general accordance with the SOP-GW-11 included in Appendix A. Specific details for the piezometer construction are provided on Figure 5. The procedures below assume that either a vibratory roto-sonic drilling rig or Geoprobe unit will be used to install the piezometers. These procedures may change based on field conditions and equipment availability.

The general depth of each borehole and the general target depth for the piezometer screen are specified in Table 7 and may be limited or increased based on field personnel observations as determined by the Field Team Leader and CPM in consultation with the Contractor QAO. Equipment, materials, and supplies used to install the piezometer will include, but is not limited to, the following:

- 1.5 inch by 5- or 10-foot Schedule 40 polyvinyl chloride (PVC) (flush-threaded) casing (number to vary per piezometer) (Figure 5).
- One 1.5-inch by 5-foot Schedule 40 PVC pre-packed screen 0.010 slot (flush-threaded) per piezometer.
- One 1.5-inch PVC bottom cap.
- One 1.5-inch slip cap.
- Field logbook and pens.
- Measuring tape.
- Sharpie marker.
- Water level probe.
- Metal tag with the identification.
- Camera and film, digital camera, or digital video camera.
- Appropriate safety PPE.

The following procedures will be performed at each new piezometer location. Construction details are provided on Figure 5.

- Once the target depth is reached (Table 7), the well screen interval will be installed in the shallowest conductive unit as determined by the Field Team Leader and CPM in consultation with the Contractor QAO.
- Backfill any over-drilled boring with hydrated bentonite chips or bentonite pellets to a depth of 2 feet or greater below the expected total depth of the well, and transition to building filter pack (10-20 Mesh Colorado Silica Sand). This will help ensure that bentonite does not swell into the screened zone.
 - Alternatively, field personnel may elect to backfill the original borehole with bentonite, drill an adjacent borehole to the desired bottom depth of the piezometer, and install the piezometer in this second borehole.
- For the Screen and Riser:
 - Each piezometer will consist of 5 feet of 1.5-inch nominal diameter schedule 40 flush-threaded PVC well screen with a slot size of 0.010-inches, with 1.5-inch nominal diameter schedule 40 flush-threaded PVC blank casing extending to approximately 2.5 feet to 3 feet above the ground surface or finished as a flush-mount at locations where an aboveground surface finish is not possible (e.g., access roads, etc.).
 - Install an appropriately sized schedule 40 slip-fit cap on top of the PVC blank casing before installing the filter pack and other components described below.
- For the Filter Pack:
 - Install the filter pack to at least 2 feet above the top of the screen.
 - Install the annular seal of hydrated bentonite chips from the top of the filter pack to 6 to 12 inches below ground surface (bgs). For shallower completions of piezometers, the thickness of the seal and/or filter pack above the piezometer screen may be reduced by field personnel, as necessary.
- For the Casing:
 - Install a 4-to-6 inch by 5-foot steel surface casing from approximately 2.5 feet bgs to approximately 2.5 feet above ground surface.
 - If the location is anticipated to be subject to frost-heave, such as in the western portion of the Site, install a longer steel surface casing that extends below the frost line.
 - In areas susceptible to flooding, the protective casing should extend high enough to be above flood level (OhioEPA, 2008).
 - In high traffic areas, 3 bollards should be installed around the piezometer.
 - Install 10-20 mesh Colorado Silica Sand from 6 inches bgs to approximately 2 inches below the top of the 1.5-inch diameter PVC.

- Mark a measuring point on the north side of the inner casing using permanent marker.
- Install a concrete pad around the surface casing.
- Provide a locking steel cap for each piezometer.
- Write the piezometer name, depth, and installation data on the underside of the locking steel cap.

Pioneer will prepare a piezometer completion log for the location and, at a minimum, it will contain the following:

- Time and date installed.
- Borehole, casing, and screen diameters.
- Bottom cap length.
- Boring depth (plus or minus 0.1 foot) in relation to the ground surface.
- Well depth (plus or minus 0.1 foot) in relation to the ground and final measuring point.
- Lithology logs.
- Casing materials.
- Screen size, length, and depth to top and bottom of screen from ground surface.
- Filter pack material, size, and thickness in relation to the ground surface.
- Seal thickness and depth below ground in relation to the ground surface.
- Depth to groundwater at time of completion, in relation to the ground and final measuring point.
- Survey-grade X and Y coordinates and elevations for the measuring point (marked on the north side of the PVC), top of protective casing, and ground surface.

All drilling equipment and accessories will be decontaminated at the completion of the piezometer installation.

4.2.2.2 Development

The piezometers will be developed following the general procedures detailed in SOP-GW-12 in Appendix A. The piezometer will be considered developed when 3 consecutive readings for turbidity are below 5 Nephelometric Turbidity Units (NTUs) or are within 10% of each other and the water quality parameters are stable, or the piezometer has been developed for 4 hours. The water quality parameters are considered stable when three consecutive readings are as follows:

- Temperature range is no more than plus or minus 1 degree Celsius (°C).
- pH varies by no more than 0.1 pH units.
- Specific Conductance (SC) readings are within 3% of the average.

If a light non-aqueous phase liquid (LNAPL) layer is detected on the groundwater table using an interface probe, the piezometer will not be developed.

Development water will be contained within a specified containment area and/or holding tank. Based on field observations, if the development water appears to contain hydrocarbon compounds, the water will be sampled for hydrocarbon compounds prior to management/disposal. The need for management/disposal options, if necessary, will be determined based on the laboratory results.

4.2.3 Geotechnical Analysis Boreholes

4.2.3.1 Drilling Equipment

Based on field conditions and recommendations from the geotechnical engineer, an appropriate drill rig will be used to log and sample solids for field testing and laboratory analysis. The Geoprobe unit will be used to drill the 2 boreholes located in the floodplain to minimize the impact to the floodplain and Silver Bow Creek (Figure 4). The drilling methods available for the 10 boreholes located on the main Site outside the floodplain (Figure 4) include the sonic drilling rig and the hollow stem auger. While the hollow stem auger is the preferred method for collecting geotechnical data on the alluvial material beneath the slag and demolition debris at the Site, the sonic rig may also be used and will provide data that meets the DQOs. The hollow stem auger will be limited to areas without slag or other hard materials. Therefore, the sonic rig may be used to drill through tougher materials (i.e., demolition debris or slag), if needed. Core samples will be examined to produce a detailed lithologic characterization log of the subsurface materials at each borehole location.

The following paragraphs include output details and general practices for each instrument as they apply to the geotechnical investigation.

Hollow Stem Auger

Where appropriate, a hollow stem auger will be used for the geotechnical investigation. Drilling will be conducted using a 6-to-8-inch outer-diameter hollow stem auger system. To temporarily store the sediment core, polyethylene sleeves designed to fit over the core barrels will be used. Each 5-foot length will be properly labeled to split the core into manageable units for storage.

Sonic Drilling Rig

Where appropriate, the sonic drilling rig will provide continuous core samples, which are anticipated to be 5 feet in length by 4 inches in diameter. To temporarily store the sediment core, polyethylene sleeves designed to fit over the core barrels will be used. Each 5-foot length will be properly labeled to split the core into manageable units for storage.

Geoprobe

The Geoprobe unit will provide continuous core samples using the dual tube soil sampling system. These core samples are anticipated to be up to 5 feet in length. The Geoprobe unit is equipped with 2 sampling systems, one that collects 2-inch core and one that collects 3-inch core, which will allow collection of Shelby tube samples. Using either of the systems will be determined by the Field Team Leader and CPM in consultation with the geotechnical engineer. To temporarily store the sediment core from the Geoprobe unit, plastic liners will be used within

the inner core barrel to collect the core samples. Each 5-foot length will be properly labeled for storage.

All three drill rigs will be equipped with the appropriate system to conduct SPTs. The SPTs will be conducted with a split spoon sampler using the hammer to drive the sampler to the ground in a minimum of three 6-inch increments. The drill rigs (auger, sonic, and Geoprobe unit) will also be equipped to take standard Shelby tube samples. Based on field conditions, the Field Team Leader and CPM in consultation with the geotechnical engineer will determine the appropriate drilling equipment to use.

4.2.3.2 General Procedures

The following general procedures will be performed at each Geotech Analysis Borehole (Figure 4) location (at the depth intervals). Note that this list is not intended to be a complete list.

- Prepare drill equipment for operation. This includes, but is not limited to, decontaminating drilling tools and sampling equipment, leveling the rig, preparing the down-hole tool, and establishing the drill location.
- Perform SPTs starting at ground surface and continuing in approximately 5-foot intervals in general accordance with the *Standard Method for Standard Penetration Test and Split-Barrel Sampling of Soils* (ASTM D1586; ASTM, 2017a included in Appendix C). Note that the SPTs will be performed by a subcontractor. The geotechnical engineer or Field Team Leader will log the number of blow counts for each test.
- Advance the auger barrel segment (anticipated to be 5 feet) to complete field testing and collect samples. Boreholes will be advanced at the direction of the Field Team Leader, CPM, or the geotechnical engineer.
- Shelby tube samples will be collected to obtain samples of clay or silt, at the discretion of the Field Team Leader or geotechnical engineer, in accordance with the *Standard Practice for Thin-Walled Tube Sampling of Fine-Grained Soils for Geotechnical Purposes* (ASTM D1587; ASTM, 2017b included in Appendix C).
- Classification and lithology of the core from each borehole will be logged and sampled following the general procedures listed below.
- Continue adding auger barrel segments and collecting samples until desired depth has been reached.
- Decontaminate the drill equipment between investigation locations by rinsing with tap water and/or using a high-pressure washer.
- Backfill borehole with bentonite hole plug.

The general depth of each borehole is specified in Table 7 and may be limited or increased based on field personnel observations.

Equipment

Equipment used to collect core samples will include, but not be limited to, the following:

- Field logbook and pens.
- Measuring tape.
- Ziplock bags.
- Chain of custody forms.
- 5-gallon buckets.
- Large brush to remove soil from split spoon sampler.
- Duct tape.
- Shelby tubes and plastic end caps.
- Decontamination equipment (pressure washer, tap water, dilute nitric acid, liquinox soap, decontamination containers, paper towels, scrub brushes, and spray bottles) (refer to SOP-DE-02 in Appendix A).
- Camera and film, digital camera, and/or digital video camera.
- GPS unit.
- Appropriate safety PPE.

Logging

A geotechnical engineer will log the number of blow counts during the SPT, log soil lithology, collect soil samples for field and laboratory testing, observe existing groundwater conditions (where encountered), inform the driller when to take Shelby tube samples, note the ease or difficulty of drilling, and record any other notable features.

Sampling and Analysis Procedures

The following general procedures will be performed at each location at the discretion of the geotechnical engineer, Field Team Leader, or CPM:

- Between boreholes, wash all utensils and drilling equipment with a detergent solution, followed by a tap water rinse, a diluted acid rinse, and a final rinse with DI water.
- Upon receiving the split spoon from the driller, open the split spoon, measure the length of recovered material, take a photograph from directly overhead, log the soil, and place in a ziplock bag labeled with the location name, soil depth interval, and date.
- Upon receiving the 5-foot core from the driller, open the bag, take a photograph from directly overhead, and log the soil. Samples may be collected at the discretion of the geotechnical engineer, Field Team Leader, or CPM.
- Upon receiving a Shelby tube from the driller, keep the Shelby tube in an upright position, place the plastic caps over the top and bottom of the Shelby tube and use duct tape or a similar material to secure and seal the caps to the Shelby tube. Place the Shelby tube in a location where it will remain upright and will be subject to minimal movement.
- Select samples may be analyzed at Pioneer's Material Testing Laboratories for moisture content, resistivity, pH, sulfate, particle size distribution, Atterberg Limits, standard

proctor, California bearing ratio, triaxial shear strength, and consolidation (Table 6) depending on borehole location and the potential infrastructure that might be located in that area.

- Place the core samples in properly labeled sample core boxes for transport (the labels will include location, depth interval, and core orientation). It is imperative that the core sample is marked clearly and is carefully transported horizontally, as it will be used for further observation, sample selection, and analysis.

Sediment cores from every borehole drilled during this project will be stored in their entirety (in increments) at the Pioneer field office at 244 Anaconda Road in Butte, Montana, or an alternate suitable location. When it has been determined that enough sample is present for design-related purposes, additional samples will be shared with other parties, transferred from Pioneer's field office, or disposed of appropriately. Sediments, drill cuttings, materials from potholing, etc. that are not sent to a laboratory will be stockpiled on the Site for disposal during the RA, disposal at the Mine Waste Repository, or other viable option at the discretion of the CPM.

4.2.4 Additional SPLP Samples

Based on the sample results from the Phase I Site Investigation (Atlantic Richfield Company, 2021d), Atlantic Richfield has identified the need to collect additional samples for SPLP analysis. These additional samples are necessary to refine the estimate of chemical leachability of slag within the Site and the extents of a potential highly leachable soil layer near piezometer BRW18-PZ08 (Figure 4). To expedite sampling and not delay the RD for the Site, Atlantic Richfield is proposing that these additional SPLP samples be collected from soil cores that were retrieved from the Site during the Phase I Site Investigation activities and archived at the Pioneer field office at 244 Anaconda Road in Butte, Montana.

While the holding time for the samples will have been exceeded, it is believed this will have little effect on the quality of the data for the COCs (arsenic, cadmium, copper, lead, and zinc) because the borehole cores have been stored under Atlantic Richfield control since they were originally removed from the ground (as early as 2018) and the COCs are relatively stable (i.e., do not easily degrade). Based on a previous agreement with Agencies (via email correspondence on March 25, 2020, and April 14, 2020), the samples will be qualified during the data validation process since they are outside the specified holding time. Atlantic Richfield recommends flagging detects as J and non-detects as UJ based on a previous agreement with Agencies. Based on these qualifications, the data will meet screening quality criteria (assuming no other issues are found during the data validation process), and per the *CFRSSI Data Management/Data Validation (DM/DV) Plan* (ARCO, 1992c), screening quality data is acceptable for engineering studies and engineering design (i.e., remedial design).

Figure 6 details the proposed additional samples for SPLP analysis and the following paragraphs detail the logic for identifying the additional samples.

Monolithic Slag:

It has been observed that SPLP test results can be greatly influenced by the degree of freshly fractured material that is included in the sample. Because monolithic slag is a form of glass, *in-situ* slag essentially encapsulates reactive material and prevents it from

weathering and is typically inert. Freshly fractured slag exposes fresh reactive material; therefore, laboratory SPLP testing on freshly fractured slag has the potential to overestimate the leachability of the *in-situ* weathered slag found at the Site. To determine a more representative SPLP result for *in-situ* weathered slag, the following procedures were completed for the slag samples collected and submitted for SPLP analysis during the Phase I Site Investigation:

- Slag samples were selected to include the smaller pieces of slag from the archived core; however, pieces were not crushed or ground prior to analysis.
- For each slag sample, an SPLP test was run twice:
 - The first SPLP test was anticipated to be representative of COC concentrations leaching from freshly fractured slag.
 - The second SPLP test (using the same sample material from the first SPLP test) was anticipated to be representative of COC concentrations leaching from *in-situ* weathered slag.

Based on the sample results from the Phase I Site Investigation, there were a number of samples where results from the second SPLP test were similar to or higher than the results from the first SPLP test indicating that the results were not yet representative of COC concentrations leaching from *in-situ* weathered slag (Atlantic Richfield Company, 2021d). Additionally, the higher SPLP results were typically from samples with solids: copper concentrations ranging from around 4,000 to 5,000 milligrams per kilogram (mg/kg). Therefore, the additional SPLP sample locations were selected based on slag samples with total copper concentrations ranging from 4,000 to 5,000 mg/kg and distributed across the Site.

Leachable Soil Layer near Piezometer BRW18-PZ08:

Based on the sample results from the Phase I Site Investigation, there was a sample collected from piezometer BRW18-PZ08 from 6.6 feet to 7.2 feet bgs that had significantly higher SPLP results than the other samples collected. Based on the lithology log for that location, this layer was soft, wet-moist, dark brown/black, medium plasticity, fines-clay/silt. Due to the anomalously high SPLP results from this location, it is warranted to further investigate and confirm these results by collecting and analyzing samples from nearby locations with similar material types. Additionally, samples will be collected above and below the lithological layer with high SPLP results (i.e., above 6.6 feet bgs and below 7.2 feet bgs) to evaluate the leachability in saturated and unsaturated conditions within these lithological layers.

All samples will be collected from the archived cores following the SOPs in the Phase III QAPP. Atlantic Richfield has retrieved the samples from the archived cores to verify there is sufficient material for analysis. The samples will be submitted to Eurofins TestAmerica for SPLP analysis (Analytical Group 13 in Table 6).

In order to obtain a representative SPLP result for *in-situ* weathered slag, Atlantic Richfield proposes to conduct multiple SPLP tests on the same material until results demonstrate that they are representative of *in-situ* weathered slag. Each sample will initially be leached using the SPLP

procedure for a total of 11 times. Leachate from each cycle will be collected and preserved; leachate from the 1st, 2nd, 3rd, 5th, 7th, 9th, and 11th leaching cycle will be analyzed. These data will be used to determine if COC concentrations leached from each slag sample are decreasing with additional leaching cycles and if the concentrations tail off and stabilize around a specific concentration (i.e., asymptotic response). The following approach will be applied to the data set for each sample:

1. No notable reduction in concentrations is observed: The SPLP concentrations for 1st leaching cycle will be used for these samples.
2. Asymptotic response is observed: If an asymptotic response is noted with the additional leaches, the data will be used to determine if the concentrations have stabilized around a specific concentration. Additional leachate cycles may be necessary.
3. A continued linear decrease in concentration is observed: If a linear decrease is observed, additional leachate cycles may be necessary until an asymptotic response is observed.

4.3 Groundwater Characterization

Note: Prior to the approval of the BRW Phase III QAPP, Agencies approved two RFCs to the BRW Phase II QAPP (RFC-BRW-2021-01 and RFC-BRW-2021-02) which enabled a supplemental groundwater and surface water sampling event to occur during low-groundwater conditions and within the allotted timeframe of the Site Investigation schedule. The DQOs detailed in this BRW Phase III QAPP cover the supplemental sampling event; however, the protocols and procedures for the supplemental groundwater sampling event are contained in the BRW Phase II QAPP, RFC-BRW-2021-01, and RFC-BRW-2021-02 (Atlantic Richfield Company, 2021b).

The following actions will be completed as part of the remaining groundwater characterization for the Phase III Site Investigation:

1. Use U.S. Geological Survey (USGS) streamflow data from USGS station 12323250, or other appropriate location, during spring months (i.e., higher flow periods) as an analog for high-groundwater conditions. Silver Bow Creek flow generally corresponds to groundwater levels and the data will provide an appropriate estimation to target the seasonally higher groundwater conditions. Based on the streamflow data, the Field Team Leader and CPM in consultation with the Contractor QAO will determine when sampling takes place. Based on historical data, it is anticipated that sampling for high-flow conditions will occur between May and June 2021. Agencies will be notified at least 24 hours prior to start of sampling.
2. Use USGS streamflow data, historical records, and other appropriate sources to determine when to conduct seasonal groundwater sampling events, besides during high- and low- groundwater and surface water conditions, to provide a representative sample of seasonal groundwater and surface water conditions, if determined to be necessary. The Field Team Leader and CPM in consultation with the Contractor QAO will determine if additional sampling is needed and when it will take place. Agencies will be notified at least 24 hours prior to start of sampling.

3. Continue to gather continuous groundwater level readings implemented under the BRW Phase I QAPP (Atlantic Richfield Company, 2021a).
4. Complete a synoptic water level measurement at all the locations to be sampled prior to the day of sampling for groundwater sampling events as deemed appropriate by the Field Team Leader and CPM in consultation with the Contractor QAO. A synoptic event consists of measuring groundwater elevations from piezometers and monitoring wells that will be sampled the following day. Water levels will be recorded as a parameter during the sampling event.
5. Record field parameters, collect groundwater and surface water samples, and analyze for specified analytes.
 - Field personnel will collect a water sample and record field parameters from each piezometer and monitoring well identified in Table 7 following the identified procedures in Section 4.4.2 and associated Standard Operating Procedures. In the “Groundwater Characterization and Loading Analysis, Analytical Group from Table 6” column in Table 7, the required samples for each location are identified and correspond to the “Analytical Group” identified in Table 6. Groundwater samples will be collected from 51 groundwater monitoring wells and piezometers (shown on Figure 7).
 - At each surface water location identified in Table 7, field personnel will collect a water sample, record field parameters, and collect flow measurements following the identified procedures in Section 4.4 and associated Standard Operating Procedures. In the “Groundwater Characterization and Loading Analysis, Analytical Group from Table 6” column in Table 7, the required samples for each location are identified and correspond to the “Analytical Group” identified in Table 6. To provide data for a future COC loading analysis, select piezometers/wells will be sampled on the same day as surface water samples are collected. These locations are identified with the superscript “4” in Table 7 and shown on Figure 8.
 - The field parameters identified in Table 6 (Group 1 and Group 2) will be recorded at each location, with the exception of concentrations using the PCP Screening Kit. The PCP Screening Kit will be used to identify any pre-existing concentrations of PCP in select wells. These wells are indicated with “2b” in the “Groundwater Characterization and Loading Analysis, Analytical Group from Table 6” column in Table 7. The samples will be analyzed in the field following the procedures in the user manual.
 - The samples will be submitted to the laboratory for the specified analyses identified in Table 6.
 - The selected groundwater and surface water sampling and/or flow measurement locations may be changed, increased, or decreased as determined by the Field Team Leader and CPM in consultation with the Contractor QAO.

The Phase I Site Investigation schedule for continuous monthly groundwater monitoring concluded in June 2021. The Phase III Site Investigation groundwater monitoring schedule will

extend the Phase I Site Investigation continuous monitoring locations through at least the conclusion of all Phase III groundwater sampling events. However, the Field Team Leader and CPM in consultation with the Contractor QAO may decide to continue the monthly groundwater monitoring past the conclusion of the Phase III groundwater sampling events.

4.3.1 Water Level Measurements

Continuous Groundwater Level Measurements

Continual water level recorders (transducers) will be monitored at the piezometer locations listed in Table 7 and set to collect a data point every 15 minutes, in a linear mode. The Phase III Site Investigation will use the transducer arrangement specified in the Phase I QAPP (Atlantic Richfield Company, 2021a) and extend the projected data collection completion date from January 2021 to the conclusion of all groundwater sampling events for Phase III. Transducers will be installed and monitored in accordance with SOP-GW-15 included in Appendix A. The proposed locations may be modified based on field observations and as approved by the Field Team Leader and CPM in consultation with the Contractor QAO.

Data from transducers will be downloaded monthly (unless needed for more frequent analysis during sampling events) and concurrently with synoptic monthly water level measurements. At the time the data from the transducers are downloaded, the transducers will be checked for proper functionality and visually inspected for fouling. If the transducer is becoming fouled, it will be rinsed with tap water. When removing transducers from piezometers, care will be taken to avoid contacting the transducer and any suspension cables with the ground surface. Should contact with the ground surface occur, the transducer and suspension cable will be rinsed with tap water to remove all foreign material.

Manual Groundwater Level Measurements

Manual water levels will be collected monthly (unless needed for more frequent analysis during sampling events) until the conclusion of Phase III groundwater sampling events from the identified locations in Table 7 using a dedicated electronic depth to water indicator tape (E-tape), unless the location must be removed or an alternate location is designated. The proposed locations may be modified based on field observations and as approved by the Field Team Leader and CPM in consultation with the Contractor QAO.

Manual water levels will be measured from the measuring point as indicated on the inner PVC well or piezometer casing, typically located on the north side of the inner PVC casing. Measuring point locations and elevations of all monitoring wells and piezometers identified in Table 7 have been or will be surveyed using a survey-grade GPS unit.

4.3.2 Groundwater Sampling

Groundwater samples will be collected from 51 groundwater monitoring wells and piezometers (shown on Figure 7) during a representative range of seasonal groundwater and surface water conditions, such as high- and low-groundwater conditions; the Field Team Leader and CPM, in consultation with the Contractor QAO, will assess if additional sampling is needed. Groundwater samples will be collected from the 51 groundwater monitoring wells and piezometers and will be

submitted to be tested for varying analytical groups, as appropriate, to support the Phase III DQOs (Table 3). Groundwater samples will be collected from the locations listed in Table 7 and analyzed for analytes specified in Table 6. The “Analytical Group” values (1 through 8 for groundwater and surface water) of the first column in Table 6 correspond to the values listed for each location under the column heading “Groundwater Characterization and Loading Analysis, Analytical Group From Table 6” in Table 7. For example, in Table 7, the first piezometer listed under the 2018 and 2019 Piezometer group, BRW18-PZ03D, is scheduled for analytical groups 1, 2a, 3, and 8 (superscript 1) specified in Table 6. These analytical groups denote the following parameters: a water level measurement (analytical group 1); temperature, specific conductance, etc. (analytical group 2a); total recoverable and dissolved metals, total recoverable phosphate, and nitrate and nitrite (analytical group 3); and LNAPL samples (analytical group 8). Note that superscript values are specific to the table in which they are listed.

The samples will be taken following the general procedures below and SOPs in Appendix A. The selected groundwater sampling locations may be changed, increased, or decreased as determined by the Field Team Leader and CPM in consultation with the Contractor QAO. Field personnel will collect a water sample using the appropriate sampling equipment (e.g., peristaltic pump, submersible pump, or bladder pump) in conjunction with a low-flow sampling methodology approved by the Field Team Leader and CPM in consultation with the Contractor QAO. All water sampling results will be recorded in a bound field logbook.

Prior to groundwater sampling, depth-to-groundwater will be measured at each piezometer / monitoring well location in accordance with SOP-GW-03 in Appendix A. After water levels have been collected, the piezometers will be purged with the appropriate sampling equipment (e.g., peristaltic pump, submersible pump, or bladder pump; corresponding SOPs are in Appendix A) until the water quality parameters (turbidity, temperature, SC, and pH) and water level have stabilized. Water quality measurements will be collected at 3- to 5-minute intervals to monitor stabilized water quality parameters. Water quality parameters will be collected in accordance with the applicable and relevant SOPs. The piezometer will be considered stable when 3 consecutive readings for turbidity are below 5 NTUs or are within 10% of each other and the water quality parameters are stable. The water quality parameters are considered stable when 3 consecutive readings are as follows:

- Temperature range is no more than plus or minus 1 °C.
- pH varies by no more than 0.1 pH units.
- SC readings are within 3% of the average.

Once the water quality parameters stabilize, samplers will collect the groundwater sample directly from the sampling equipment and place it into appropriate sample containers. The sampling procedures will follow the applicable SOPs in Appendix A, which adhere to or expand upon the *CFRSSI SOPs* (ARCO, 1992d). Table 6 lists the detailed procedures for sample collection and handling.

4.4 Silver Bow Creek Loading Analysis

The purpose of the Silver Bow Creek loading analysis is to determine the changes in chemical concentrations and load in Silver Bow Creek from the area between SS-05B and SS-06A (Figure 2) during a representative range of seasonal groundwater and surface water conditions to guide the remedy design and implementation. The loading analysis will use a combination of manual flow measurements and radon tracing methodology to locate sub-reaches along Silver Bow Creek where impacted groundwater is upwelling and quantify the load to Silver Bow Creek.

4.4.1 Flow Measurements and Surface Water Sampling

Flow measurements and samples will occur during a representative range of seasonal surface water conditions, such as low- and high-flow conditions in Silver Bow Creek. It is anticipated that peak high groundwater loading from groundwater to surface water will occur on the declining limb of peak seasonal streamflow. These conditions will be targeted by this data collection effort, if possible. Streamflow data will be monitored as described in Section 4.3 to determine when sampling will occur. When taking flow measurements and samples, the field team will attempt to identify a day of favorable weather conditions, then start at the downstream-most sampling location and move upstream. Flow data and samples will be collected from the existing staff gage locations within Silver Bow Creek (Figure 8). Staff gages installed in the Hydraulic Control Channel (HCC) will provide water level data but will not function as sample locations for the Phase III Site Investigation, as shown in Table 7. The number and location of the staff gages may be modified as determined by the Field Team Leader and/or CPM in consultation with the Contractor QAO.

It is anticipated that the field team will be able to collect flow measurements and samples by wading. Stream flow measurements will be conducted using a cross section of the stream channel. Field personnel will use a FlowTracker2 following the SOPs in Appendix A. *Streamflow Measurement with Marsh McBirney or FlowTracker2 Flow Meter (SOP-WFM-05)* is based on the FlowTracker2 flow meter User's Manual, which states the measurement interval is dependent on width of the creek section and no interval size shall have greater than 5% of total flow.

Staff gages will be read to an accuracy of 0.01 feet before and after flow measurements are taken. The Field Team Leader will identify any change in flow over the duration of each sampling event using the nearby USGS station 12323250 or other appropriate location. The Field Team Leader will coordinate with other activities occurring in the Silver Bow Creek corridor that may affect sampling and stream flow measurement results.

The Silver Bow Creek Loading Analysis will likely consist of seven groundwater sample locations and seven surface water sample locations (indicated by superscript 4 in Table 7). The number and location of samples may be modified as determined by the Field Team Leader and/or CPM in consultation with the Contractor QAO. Groundwater and surface water samples analyzed for radon are represented by analytical group 7, listed under the "Groundwater Characterization and Loading Analysis, Analytical Group From Table 6" in Table 7. The

superscript 4 in Table 7 denotes groundwater sample locations, surface water sample locations, and staff gage measurement locations to be collected within one day for the Silver Bow Creek Loading Analysis.

Samples will be collected per SOP-SW-01 in Appendix A. Samples will be collected using equal width increment (EWI) sampling technique (Atlantic Richfield Company, 2018). To use the EWI method, the sampler starts at the right edge of water (REW), collects a small portion of water into the sample container while avoiding touching the bottom of the streambed so that sediment is not stirred up during sample collection, steps towards the left side of the stream, and collects a second portion of water into the sample container. The sampler continues in this manner until the sample container is filled and the left edge of water (LEW) is reached. The field team will use common sense dividing the stream reach into equal increments.

4.4.2 Data Analysis

Data collected from specified monitoring wells and piezometers (Table 7) during the groundwater sampling (Section 4.3.2) and from the surface water sampling (Section 4.4.1) will be used to complete the loading analysis. The analysis of the data collected from the field activities will be similar to the radon tracing methodology described in the *Final Revised 2011 Blacktail Creek and Silver Bow Creek Radon Tracing and Thermal Imaging Survey Technical Memorandum* (Radon Tracing Memo) (Atlantic Richfield Company, 2016). That methodology is described below.

Estimation of Surface Water Gain using Radon Concentrations

Results from the radon analysis combined with surface water flow monitoring will help define locations where groundwater is upwelling into surface water. The relationship between surface water and groundwater is defined by the mass balance equation:

$$(Q_{us} * C_{us}) + (Q_{gw} * C_{gw}) = (Q_s * C_s) \quad \text{(Equation 1)}$$

Where:

- Q_{us} = Flow rate of stream at upstream sample location in cubic feet per second (cfs)
- C_{us} = Concentration of radon at upstream sample location in picocurie per liter (pCi/L)
- Q_{gw} = Groundwater inflow or gain (cfs)
- C_{gw} = Concentration of radon in groundwater (pCi/L)
- Q_s = Flow rate of stream at sample location (cfs)
- C_s = Concentration of radon at sample location (pCi/L)

With stream flow and radon measurements known, the groundwater discharge between two locations in the stream is determined by rewriting Equation 1:

$$Q_{gw} = \frac{(Q_s * C_s) - (Q_{us} * C_{us})}{C_{gw}} \quad \text{(Equation 2)}$$

It is necessary to use only the upstream discharge measurement of flow (Q_{us}) in the calculation to determine the total flow downstream rather than the measured flow downstream in case there is

both a loss and a gain in the stream reach. This is accomplished by substituting for Q_s in Equation 2 using the following:

$$Q_s = Q_{us} + Q_{gw} \quad (\text{Equation 3})$$

Using the product from Equation 3 and substituting it back into Equation 2, the resulting equation through algebraic manipulation becomes:

$$Q_{gw} = Q_{us} * \frac{(C_s - C_{us})}{(C_{gw} - C_s)} \quad (\text{Equation 4})$$

Equation 4 allows calculation of the total groundwater discharged into a specific surface water reach. To account for the natural off-gassing of radon, each downgradient station will be adjusted individually using the procedures and results in the Radon Tracing Memo (Atlantic Richfield Company, 2016).

This methodology will be adjusted as needed to meet the requirements of the Site.

4.5 Silver Bow Creek Sediment Sampling

Two Silver Bow Creek locations will be sampled as part of the Silver Bow Creek Sediment Sampling (sediment sampling) component of the Phase III Site Investigation (Figure 4). The purpose of the sediment sampling is to determine sediment particle size distribution. Sediment particle size distribution will be analyzed at Pioneer's Materials Testing Laboratory (Analytical Group 14 from Table 6). The stream sediment sample particle size distribution will guide calculations to determine the sediment transport capacity through the Site and assist in the design of the realigned Silver Bow Creek and 100-year floodplain.

Stream sediment sampling will be conducted according to all relevant and applicable SOPs in Appendix A, particularly SOP-S-03. The field team will attempt to identify a day of favorable weather conditions to collect sediment samples. Sediment samples will be collected from the locations within Silver Bow Creek as indicated on Figure 4, and enough sample volume will be collected to adequately characterize the sediment at each location. It is anticipated that the field team will be able to collect stream sediment samples by wading and using a clean shovel. Sediment samples will be collected and placed directly into clean 5-gallon buckets. Sample location, depth, and range will be determined in the field using professional judgement based on field conditions. Sampling methods will be adjusted as needed to meet the requirements of the particle size distribution analysis (ASTM D6913).

Sample locations will be recorded with the GPS. All relevant observations will be recorded in a field logbook if applicable. Sediment samples will be transported directly to Pioneer's Materials Testing Laboratory for analysis. Pioneer's Materials Testing Laboratory will analyze the sediment samples as detailed in Table 6 (Analytical Group 14) and Section 4.6.

The number and general location of the sediment sampling may be modified as determined by the Field Team Leader and/or CPM in consultation with the Contractor Quality Assurance Officer (QAO) (Section 7.0).

4.6 Standard Operating Procedures

This BRW Phase III QAPP includes SOPs that apply to particular field activities, and the SOPs are referenced in the appropriate sections throughout this report and are included in Appendix A. Depending on circumstances and needs, it may not be possible or appropriate to follow the SOPs exactly in all situations due to Site conditions, equipment limitations, and limitations of the standard procedures. When necessary to perform an activity that does not have a specific SOP, or when the SOP cannot be followed, existing SOPs may be used as a general guidance or similar SOPs (not listed in this report) may be adopted if they meet the project DQOs. All modifications or adoptions will be approved by the Field Team Leader, CPM, and Contractor QAO and documented in the field logbook and/or the final project report, as appropriate.

4.7 Documents and Records

4.7.1 Sample Labeling and Identification

Soil Samples

A sample number system will be used to uniquely identify the project site, the sample medium, and the specific sample location and depth interval. The sample identification number will be derived from the borehole number with the Site Name followed by the sample interval enclosed in parentheses. For example, a sample designated BRW21-BH32(1.6-3.1) describes a sample from borehole BRW21-BH32 taken from a depth of 1.6-3.1 feet below existing grade. All measurements will be decimal feet. There will be no blank spaces permitted in the identification. The following is an example of the sample numbering system:

Sample Number: **BRW21-BH02(1.6-3.1)-04192021**

Location/Year: “BRW21” - BRW project area, installed in 2021.

Type: “BH” – Borehole
 “PZ” – Piezometer
 “SBC” – Silver Bow Creek

Location/Number: “02” - Sample Location (corresponds with Borehole ID No.). All sample locations will be plotted on the sampling maps.

Depth Interval: “(1.6-3.1)” (upper limit-lower limit). If sample is a duplicate, label the interval “T.” Do not use specific intervals. Intervals and duplicates will be recorded in the field log or logbook.

Date: “04192021” - sample collected on April 19, 2021.

For field duplicates, the depth interval will be replaced by “(T).” For example, a duplicate of BRW21-BH02(1.6-3.1)-04192021 would be BRW21-BH02(T)-04192021. Field duplicate samples will be recorded in the log or logbook, and the primary sample will be clearly indicated.

All subsample locations and depths will be described in the data log. All samples will be labeled in the field with documentation of the date and time of sample collection, the sample number,

sample container type, analyses requested, and the sampler's initials. A permanent marker will be used for labeling.

All soil samples will be collected in the proper sample container. The sample ID, date, and depth interval of the sample will be written on the sample container with an indelible marker. Samples will be stored, handled, and packaged as described in Section 4.7.3 and Table 6. A copy of the chain of custody record will accompany the samples during shipment and will serve as the laboratory request form. The chain of custody form will specify the type of analysis requested for each individual sample. The original form will be maintained with the field notes and in the project records.

Groundwater and Surface Water Samples

As with soil sampling, a sample number system will be used to uniquely identify the project site, the sample type, and the specific sample location. The following is an example of the sample numbering system:

Sample Number: BRW21-PZ02T-04192021

<u>Location/Year:</u>	“BRW21” - BRW project area, installed or recorded in 2021. For groundwater samples, the location/year label “BRW21” refers to piezometers installed in 2021. For surface water samples, the location/year label “BRW21” refers to a 2021 sampling event.
<u>Type:</u>	“PZ” – Piezometer
<u>Location/Number:</u>	“02” – Piezometer location.
<u>Duplicates:</u>	“T” – Duplicates or “Twin” samples will be recorded on the field log or logbook.
<u>Date:</u>	“04192021” - sample collected on April 19, 2021.

All samples will be labeled in the field with documentation of the date and time of sample collection, the sample number, sample container type, analyses requested, and the sampler's initials. A permanent marker will be used for labeling. All groundwater and surface water samples will be collected in the appropriate sample container, with preservative in place from the laboratory (if necessary). Samples will be taken or shipped to the identified laboratory for analyses. Samples will be stored, handled, and packaged as described in Section 4.7.3 and Table 6. A copy of the chain of custody record will accompany the samples during shipment and will serve as the laboratory request form. A chain of custody form will be completed that specifies the type of analysis requested for each individual sample. The original form will be maintained with the field notes and in the project records.

4.7.2 Field Documentation

4.7.2.1 Field Logbook

To provide a permanent record of all field activities, field personnel will document all activities in a bound field logbook (refer to field SOPs in Appendix A). This will include a description of conditions during sampling activities. When field logbooks are used, each logbook will have a

unique document control number, be bound, and have consecutively numbered pages. All entries will be in waterproof ink, and any mistakes will be lined out with a single line and initialed by the person making the correction. Whenever a sample is collected or a measurement is made, a detailed description of the sample location and any additional observations will be recorded. The GPS coordinates will be recorded when appropriate. Individual field team members may be responsible for required documentation based on specific tasks assigned by the Field Team Leader or CPM.

All significant observations, measurements, relevant data, and results will be clearly documented in the data log or the field logbook. At a minimum, the following will be recorded:

- A description of the field task.
- Time and date fieldwork started.
- Location and description of the work area including sketches if possible, map references, and references to photographs collected.
- Names and titles of field personnel.
- Name, address, and phone number of any field contacts or Site visitors (e.g., Agency representatives, auditors, etc.).
- Meteorological conditions at the beginning of fieldwork and any ensuing changes in the weather conditions.
- Details of the fieldwork performed and the field data sheets used.
- All field measurements made.
- Any field analysis results.
- Personnel and equipment decontamination procedures.
- Deviations from the BRW Phase III QAPP or applicable field SOPs (Appendix A).

For boreholes, the following entries will be made:

- Lithologic log of the boring indicating material types, from and to depths, rock content, color, presence of water, etc.
- Depth intervals from the ground surface for each soil horizon and total depth of the boring.
- Photograph or video of each boring with a staff gage or tape measure for scale to document existing conditions. Include Site name ID in photograph using a white board or note pad.
- Abnormal occurrences, deviations from the BRW Phase III QAPP, or other relevant observations.

For any field sampling work the following entries will be made:

- Sample location and ID number.
- Sample type collected.

- Date and time of sample collection.
- Sample location descriptions and designations, soil type and texture (e.g., sand, silt, etc.), grain-size, and color (in the field). Further sample information will be included with the laboratory results.
- Split samples taken by other parties (note the type of sample, sample location, time/date, name of individual, individual's company, and any other pertinent information).
- Sampling method, particularly any deviations from the field SOPs (Appendix A).
- Documentation or reference of preparation procedures for reagents or supplies that will become an integral part of the sample (if any used in the field).
- Sample preservation (if used).
- Decontamination procedure (if used).
- Sample custody.

The lithologic information for boreholes will be transcribed into a spreadsheet or database that can be used with Strater® or other appropriate lithologic log software.

4.7.2.2 Field Photographs

Photographs will be taken of sampling locations and field activities using a digital camera. When practical, photographs should include a scale in the picture as well as a white board with relevant information (e.g., time, date, location, sample number, etc.). Additional photographs documenting Site conditions will be taken, as necessary. Documentation of all photographs taken during sampling activities will be recorded in the bound field logbook or appropriate field data sheets (refer to field SOPs in Appendix A), and will specifically include the following for each photograph taken:

- Time, date, and location.
- Photograph or video number from the camera or video recorder.
- The identity of the person taking the photograph/video.
- Direction that the photograph was taken and description of the subject photographed.

The digital files will be placed with the electronic project files with copies of supporting documentation from the bound field logbooks.

4.7.3 Sample Handling, Documentation, and Shipping

As applicable, samples will be either hand delivered or shipped via Federal Express or UPS to the appropriate laboratory under strict EPA chain of custody procedures. Samples will be shipped in appropriate containers that will prevent detrimental effects to the sample.

Sample containers and holding times are listed in Table 6. All procedures will strictly follow appropriate protocols and field SOPs in Appendix A. Chain of custody records will be kept with the samples and custody seals will be placed on the sample storage containers (coolers).

All samples not submitted to the laboratory will be archived. When it is determined that the samples are no longer needed, they will be disposed of at the Mine Waste Repository.

4.7.4 Chain of Custody

The SOP for chain of custody (SOP-SA-04) is in Appendix A. Maintaining the integrity of the sample from collection through data reporting is critical to the sampling and analytical program. This process includes the ability to trace the possession and handling of samples from the time of collection through analysis and final disposition. This documentation of the sample's history is referred to as chain of custody. A sample is considered to be under an individual's custody if it is in that individual's physical possession, in view of the individual after taking possession, or secured by that individual so that no one can tamper with the sample.

The components of the field chain of custody (chain of custody form, labels, and custody seals) and laboratory chain of custody (chain of custody form, custody seals, and laboratory custody) are described in this section.

4.7.4.1 Chain of Custody Form

A chain of custody form will be completed and will accompany samples as appropriate. A standard form will be provided from each laboratory. The form will include the following information:

- Project code.
- Project name.
- Sampler's signature.
- Sample identification.
- Date sampled.
- Time sampled.
- Analysis requested.
- Remarks.
- Relinquishing signature, date, and time.
- Receiving signature, date, and time.

4.7.4.2 Custody Seals

Custody seals are used to detect unauthorized tampering with samples following sample collection up to the time of analysis. Custody seals will be applied to the shipping containers when the samples are not in the sampler's custody.

4.7.4.3 Laboratory Custody

Laboratory custody procedures will generally conform to procedures established for the EPA Contract Laboratory Program (CLP) Statement of Work (SOW) for Superfund Analytical Methods SFAM01.1 (EPA, 2020a). These procedures include the following:

- Designation of sample custodian.
- Correct completion of the chain of custody form, recording of sample identification numbers, and documentation of sample condition upon receipt.
- Laboratory sample tracking and documentation procedures.
- Secure sample storage.

The samples will be delivered to the laboratory for analysis in a timely manner to ensure the requested analyses can be performed within the specified allowable holding times. The sample will be hand delivered or addressed to a person in the laboratory who is authorized to receive samples (laboratory sample custodian).

4.8 Field Analysis Methods

This section describes field analysis methods, including XRF analysis and PID screening.

4.8.1 XRF Analysis

Field XRF Analysis

Field XRF analysis will be used mainly as a guide to estimate the first lithological layer in each boring which passes the Waste Identification Screening Criteria (EPA, 2020a) and to identify materials from borings that are to be submitted to the laboratory for SPLP (Section 4.2), and as deemed necessary based on field observations.

The XRF analysis will be conducted using a Niton™ XL3 XRF Analyzer (XL3) and following the procedures outlined in SOP-SFM-02 in Appendix A as well as the XL3 user manual to ensure that the techniques employed are appropriate for the analytes of interest. Samples will be collected in a ziplock bag and mixed. Samples will be dried if conditions require and are deemed necessary by field personnel. If a portable heater or oven is used to dry samples, the sample will be dried while maintaining a temperature that does not exceed the boiling point of water (100 °C).

Official XRF Analysis

Limited XRF analysis will be conducted in the event a lithological layer is too thin and there is not enough soil to fulfill the required sample volume required for laboratory metals analysis. In this instance, a sample will be collected and prepped for XRF analysis at Pioneer's field office at 244 Anaconda Road in Butte, Montana, after sampling activities have finished.

The XRF analysis will be conducted using a XL3 and following the procedures outlined in SOP-SFM-02 in Appendix A as well as the XL3 user manual to ensure that the techniques employed

are appropriate for the analytes of interest. Prior to completing analysis with the XRF, any large aggregate will be removed from the sample. For gravel or rocky soil, a sieve may be used to remove the large aggregates. Samples will be dried prior to analysis. Samples will be collected in a ziplock bag and mixed. The samples will then be placed in a small plastic cup with a mylar film cover for analysis.

4.8.2 PID Screening Analysis

Screening for hydrocarbon compounds will be conducted using two PIDs, one with a 9.8 eV lamp and another with a 10.6 eV lamp. The procedures for using the PID unit are summarized below and additional detail is included in applicable user manuals. It is anticipated that a MiniRae 3000 unit and a UltraRAE 3000+ unit will be used, or equivalent.

Initially, the PIDs will be used to detect hydrocarbon compounds from soil with visual evidence of soil staining or if an odor is detected. A slow sweeping motion will be used to detect hydrocarbon compounds with the PID for soil from borehole cores, immediately after they are split.

Once it has been determined that volatile petroleum hydrocarbon (VPH) might be present, a combustible gas meter will be used to monitor the atmosphere for hazardous conditions. The combustible gas meter will be mounted on or near the drill rig to monitor conditions near the drill hole. If hazardous conditions are present, appropriate action will be taken by safety personnel.

If hazardous conditions are not present, a portion of the sample will immediately be collected in the appropriate sample container (Table 6) and the remainder placed in a ziplock bag with air space at the top above the sample (headspace) to allow testing using the headspace screening method. For the headspace screening method, the sample is brought to room temperature, the sample is mixed or shaken depending on soil type to allow the contaminants to volatilize, and then the PID probe is inserted into the bag and the headspace concentration is measured and recorded.

4.9 Laboratory Analysis Methods

The anticipated laboratory analytical methods to be used are detailed below. Laboratory analysis of samples collected during the course of this study will be performed by laboratories with established protocols and quality assurance (QA) procedures that meet or exceed EPA guidelines. EPA-approved methods will be used for all applicable equipment (refer to Table 6). Standard laboratory turnaround times will be requested.

4.9.1 Total Metals

Samples collected from boreholes will be sent for laboratory metals analysis analyzed by ICP-MS. Table 6 includes the analyte list and a description of the analytical technique. The ICP-MS laboratory sample results will be used to better determine the total mass of COCs and other constituents currently present within waste materials and the alluvial aquifer system at the Site.

4.9.2 Hydrocarbon Compounds

Soil that appears to contain hydrocarbon compounds (via sight and/or smell or detection with a PID) may be analyzed for VPH, extractable petroleum hydrocarbon (EPH) fractionation with polycyclic aromatic hydrocarbons (PAH), and lead scavengers (Table 6). All visual and olfactory observations of suspected hydrocarbon compounds will be confirmed with a PID prior to collecting a sample.

4.9.3 LNAPL Samples

If the interface probe indicates there is an LNAPL layer on the surface of the groundwater, a sample will be collected. If an LNAPL layer is present, a pure LNAPL sample will be collected, if possible. If a pure sample is not possible, a mixed sample of LNAPL and groundwater will be collected. The analytical procedures and proper preservation methods are detailed in Table 6.

4.9.4 Groundwater Analysis

Groundwater samples will be collected at the locations listed in Table 7 and analyzed for analytes specified in Table 6. The “Analytical Group” values (1 through 8 for groundwater and surface water) of the first column in Table 6 correspond to the values listed for each location under the column heading “Groundwater Characterization and Loading Analysis, Analytical Group From Table 6” in Table 7. The analytical procedures for these analytes are identified in Table 6. Note that superscript values are specific to the table in which they are listed. Low-flow sampling parameters will be used to estimate the hydraulic conductivity of the screened aquifer interval (Robbins et al., 2009).

4.9.5 Geotechnical Samples

Geotechnical samples will be analyzed for the parameters specified in Table 6 and Table 7. These samples will be sent to Pioneer’s Material Testing Laboratories for analysis.

4.9.6 SPLP Samples

The BRW soil and slag samples will be collected and analyzed for parameters specified in Table 6, Analytical Group 13. Table 6 includes the analyte list and a description of the analytical technique. The sample results will be used to evaluate the leachability of *in-situ* waste at BRW and refine the Leapfrog model waste removal boundary to target materials with a higher potential to leach metals and impact groundwater quality, which will potentially reduce the volume of groundwater within the Site that must be hydraulically controlled per the BPSOU CD.

4.9.7 Silver Bow Creek Sediment Samples

Sediment samples will be analyzed for particle size distribution as detailed in Table 6, Analytical Group 14. These samples will be sent to Pioneer’s Material Testing Laboratories for analysis.

4.10 Quality Assurance/Quality Control Samples

4.10.1 Field Quality Control Samples

Field QC samples are used to identify any biases from transportation, storage, and field handling processes during sample collection and to determine sampling precision. All field QC samples will be shipped with field samples to the laboratory per SOP-SA-01 in Appendix A. Brief descriptions of the field QC samples are below along with when and how many are to be collected.

Field Duplicate

Field duplicates will be collected for the soil, groundwater, and surface water sampling. A field duplicate is an identical, second sample collected from the same location, in immediate succession of the primary sample, using identical techniques. This applies to all surface water, groundwater, and soil sampling procedures including instream grab samples, pumps, and other water sampling devices. The duplicate sample will have its own sample number. Duplicate samples will be sealed, handled, stored, shipped, and analyzed in the same manner as the primary sample. Both the primary sample and duplicate sample will be analyzed for identical chemical parameters by the laboratory. The analytical results of the primary and duplicate sample will be compared to determine sampling precision. Field duplicate samples will be collected at a frequency of at least 1 per 20 samples (5%) (for all soil, groundwater, and surface water samples) or once per sampling event, whichever is more frequent.

Equipment, Cross Contamination, or Rinsate Blank

Equipment contamination blanks will be collected for the groundwater sampling effort. No equipment contamination blanks will be collected for the core collection sampling effort or for surface water sampling. All soil and surface water sampling equipment is anticipated to be *one-time use*. The drilling augers, casing, drill rods, and samplers will be properly decontaminated between boreholes. Therefore, no equipment, cross contamination, or rinsate blank samples will be submitted for soil or surface water sampling unless the equipment must be decontaminated and used between samples.

If equipment, cross contamination, or rinsate blank samples are necessary, they will be collected after sampling equipment is decontaminated or prior to sampling activities. An equipment blank is prepared by running distilled, DI, or analyte-free water through or over the cleaned, decontaminated sampling equipment; gathering the water in a sample collection bottle; and adding the appropriate chemical preservatives. Analysis on the equipment blanks will assess the adequacy of the decontamination process as well as the potential contamination of samples by the containers, preservatives, and filters. The appropriate sample number will be placed on the collection bottle and recorded in the project logbook as an equipment blank. The equipment blank will be analyzed for identical chemical parameters by the laboratory as a natural sample collected from the equipment. A minimum of 1 equipment blank is required for every 20 natural samples collected.

Field Blank

Field blanks will be collected for the groundwater and surface water sampling effort. A field blank is a sample bottle containing DI or analyte-free water and appropriate preservatives and is prepared in the field. A sample bottle is randomly chosen from bottles received by the contract laboratory or supplier, and DI or analyte-free water is poured directly into the sample bottle while in the field and the bottle is preserved and shipped to the laboratory with the field samples. Field blanks must be prepared in the field and help evaluate the potential for possible contamination from the sampling environment. The field blank will have its own unique sample number and will be recorded in the project logbook as a field blank or bottle blank. Field blanks will be prepared at a frequency of at least 1 field blank per 20 natural samples collected.

Temperature Blank

A temperature blank is a vial of water that accompanies the samples that will be opened and tested upon arrival at the laboratory to ensure that the temperature of the shipping container was less than 6 °C. One temperature blank is required for each cooler shipped to the laboratory.

Trip Blank

One trip blank is required per sampling event when volatile organic compound (VOC) samples are collected. Trip blanks are used to determine if samples were contaminated during storage and/or transportation back to the laboratory. A trip blank is only required for VOC sampling. A trip blank is prepared for field personnel by the contract laboratory staff prior to the sampling event and is shipped and stored in the same cooler with the investigative VOC samples throughout the sampling event. At no time after their preparation are trip blanks to be opened before they reach the laboratory. Trip blanks should be kept on ice in the cooler, along with the VOC samples during the entire sampling run. They must be stored in an iced cooler from the time of collection, while they are in the sampling vehicle, until they arrive at the laboratory.

4.10.2 XRF Quality Control Samples

The XRF QC samples will be collected and used to assess the accuracy and precision of the XRF data. The XRF QC samples required are described below.

Energy Calibration Check

Field personnel will run a preprogrammed energy calibration check on the equipment at the beginning of each working day. If the individual believes that drift is occurring during analysis, that individual will run the energy calibration check. The energy calibration check determines whether the characteristic X-ray lines are shifting, which would indicate drift within the instrument.

Silicon Dioxide Standard

The silicon dioxide (SiO₂) sample, as provided by Niton, is a "clean" quartz or silicon dioxide matrix that contains concentrations of selected analytes near or below the machine's lower limit of detection. These samples are used to monitor for cross contamination. Field personnel will analyze this sample at the beginning of each day, once per every 20 samples, and at the end of each day's analysis. The sample information will be recorded as "SIO2" on XRF field data sheets. This sample will also be analyzed whenever field personnel suspect contamination of the

XRF aperture. Any elements with concentrations above the established lower limit of detection will be evaluated for potential contamination. If it is determined that the concentration is higher than that recorded at the start of the day, the probe window and the silicon dioxide sample will be checked for contamination. If it is determined that contamination is not a problem, and the concentration is significantly above the limit of detection, the sample result will be qualified by the XRF operator as 'J' estimated, and the problem recorded on the XRF field data sheet and in the logbook. If the problem persists, the XRF will be returned to Niton for calibration.

Calibration Verification Check Samples (Standards)

Calibration verification check samples help check the accuracy of the XL3 and assess the stability and consistency of the analysis for the analytes of interest. One to 3 (preferably) of the check samples will be analyzed at the start of each day, once per every 20 samples, and as the last analysis. Results for the check sample (standard reference material [SRM]) will be recorded on the individual XRF field data sheets and identified as a check sample. There are 3 Niton-provided SRM check samples: NIST 2709a- Joaquin Soil (2709), USGS SdAR-M2 (SRM created by the USGS), and a Resource Conservation and Recovery Act (RCRA) sample. There are also Niton-provided, machine-specific expected results for several elements for the check samples. Pioneer has refined the range of expected results for each SRM standard for each of the field XRF units in use. The measured values of a standard will be compared to the expected results. If a measured value falls outside this range, then the check sample will be reanalyzed. If the value continues to fall outside the acceptance range, this information will be noted on the XRF log. If any of the check sample results indicate that the XRF is not analyzing accurately, the XRF will be cleaned, turned off, and the energy calibration rerun. This information will be noted in the logbook and on the XRF field data sheet. The batch of samples analyzed prior to the unacceptable calibration verification check samples will be reanalyzed. If 1 standard continues to be outside of the expected range, it may indicate that the standard has been contaminated and needs replacing. If more than 1 standard is falling outside of the expected range, Niton will be contacted and the machine may be returned for calibration.

Duplicate Samples

The XRF duplicate samples will be analyzed to assess reproducibility of field procedures and soil heterogeneity. To run an XRF duplicate sample on the Niton XL3, field personnel will remove the sample cup/ziplock from the analytical stand, knead the ziplock bag once or twice/rotate the sample cup, and replace it in the stand to be analyzed a second time. XRF duplicate samples will be recorded on the XRF field data form with a D designator in the sample identification number. A XRF duplicate sample will be analyzed at the rate of at least 1 per 20 natural samples.

Replicate Samples

Field personnel will analyze an XRF replicate sample at the rate of at least 1 per 20 XRF samples. To run a XRF replicate sample on the Niton XL3, once the primary sample analysis has been completed, the XRF is restarted to analyze the same sample a second time with the same soil in the XRF aperture. XRF replicate samples help in assessing the stability and consistency of the XRF analysis. XRF replicate sample results will be recorded on the XRF field data form and designated with an R in the sample identification number.

4.10.3 Laboratory Quality Control Samples

Laboratory QC samples are introduced into the measurement process to evaluate laboratory performance and sample measurement bias. Laboratory QC samples can be prepared from environmental samples or generated from standard materials in the laboratory per the internal laboratory SOPs. Standard laboratory QC sample information is listed below.

Method Blank

The method blank (MB) samples will be prepared and analyzed for every 20 samples analyzed. The MB is laboratory DI water that has gone through the applicable sample preparation and analysis procedure. Control limits vary based on the laboratory method performed (Table 6) and are contained in the applicable laboratory method and SOP. Failure will trigger corrective action and the blanks will be reanalyzed. All samples affected will be footnoted with the appropriate flag to document contamination in the blank.

Laboratory Control Sample

The LCS will be prepared and analyzed for every 20 samples analyzed. Control limits vary based on the laboratory method performed (Table 6) and are contained in the applicable laboratory method and SOP. Failure will trigger corrective action and the analysis will be terminated, the problem corrected, and the samples associated with that LCS reanalyzed. If reanalysis of the samples fails, the samples affected by the failing LCS elements need to be re-digested and reanalyzed.

Matrix Spike/Matrix Spike Duplicate

The matrix spike (MS) and matrix spike duplicate (MSD) samples will be prepared and analyzed at different frequencies based on the laboratory method performed. The control limits also depend on the method used (Table 6) and are contained in the applicable laboratory method and SOP. If the %R for the MS and MSD falls outside the control limits, the results are flagged as outside acceptance criteria along with the parent sample. If the RPD exceeds the acceptance criteria, the MSD sample and associated parent sample will be flagged.

Post Digestion Spike

Post digestion spikes (PDS) will be prepared and analyzed at different frequencies based on the laboratory method performed. The control limits also depend on the method used (Table 6) and are contained in the applicable laboratory method and SOP.

Laboratory Duplicate Sample

The laboratory duplicate sample (LDS) will be prepared and analyzed for every 20 samples analyzed. An LCS and laboratory control sample duplicate (LCSD) pair or an MS and MSD sample pair may be used as the LDS. Control limits will vary based on the QC sample used. Failure will trigger corrective action and a single reanalysis of the respective failing QC sample is allowed. If the reanalysis is outside the acceptance criteria, the analysis must be terminated, the problem corrected, the instrument recalibrated, and the calibration re-verified.

4.11 Instrument/Equipment Testing, Inspection, Maintenance and Calibration

To ensure continual quality performance of all instruments and equipment, testing, inspection, and maintenance will be performed and recorded as described in this section. All field and laboratory equipment will be operated, maintained, calibrated, and standardized in accordance with all EPA and manufacturer's recommended procedures.

4.11.1 Field Equipment

Field equipment will be examined to verify that it is in proper operating order prior to its first use. Equipment, instruments, tools, gages, and other items requiring preventative maintenance will be serviced and/or calibrated in accordance with the manufacturer's specified recommendations, as necessary. Field equipment will be cleaned (decontaminated) and safely stored between each use. Any routine maintenance recommended by the equipment manufacturer will also be performed and documented in field logbooks. Calibration of field equipment will be completed in the field at the beginning of each day and recorded in the field logbooks. Any equipment deficiencies or malfunctions during fieldwork will be recorded as appropriate in the field logbooks. The SOPs for the field equipment are in Appendix A.

Groundwater Meter - Multi-Parameter Probe

The multi-parameter probe will be used to record parameters during purging to ensure field measurements have stabilized as defined in previous sections and in the field equipment SOPs (Appendix A). To accommodate field meters, discharge from the sampling pump will be directed through a flow-through cell for the multi-parameter probe so that parameters can be measured until stabilized. Once parameters have stabilized, the flow-through cell will be disconnected and samples for field and laboratory analysis will be collected directly from the tubing. This will ensure that the tubing has acclimated to the water chemistry and the water being sampled is represented by the stabilized field parameters.

Modern Water RaPID Assay PCP Screening Kit

If available, the PCP screening kit will be used to identify any pre-existing concentrations of PCPs in the Phase III Piezometers. Samples will be collected while analyzing the physiochemical properties of the groundwater. The samples will be analyzed following the procedures in the user manual. Due to limitations regarding the manufacturing of the PCP screening kit (i.e., extended lead time required and limited production due to Covid-19 pandemic), the PCP screening kit may not be available for use for the Phase III Site Investigation. Since all locations where the PCP screening kit is intended to be used will also have samples collected for PCP laboratory analysis, the DQOs for the project will not be affected if the PCP screening kit is unavailable.

XRF Unit

The XRF analysis will be conducted using a Niton™ XL3 XRF Analyzer (XL3) and following the procedures outlined in SOP-SFM-02 in Appendix A as well as the XL3 user manual to ensure that the techniques employed are appropriate for the analytes of interest. Additional details on the operation of the XRF are included in Section 4.8.1.

PID Unit

Screening for hydrocarbon compounds will be conducted using two PIDs, one with a 9.8 eV lamp and another with a 10.6 eV lamp. The procedures for using the PID unit are included in Section 4.8.2 as well as in the applicable user manual. It is anticipated that a MiniRae 3000 unit and an UltraRAE 3000+ unit will be used, or equivalent.

Transducers

Transducers will be installed and programmed in accordance with SOP-GW-15 in Appendix A. Transducers will be maintained per manufacture specifications. Table 7 provides the specific details including the locations where transducers will be installed.

The following data screening steps will be taken to ensure the water level measuring device data accurately represents field conditions.

Compensation: Raw water level data will be barometrically compensated and manually adjusted in a Microsoft Excel spreadsheet to match acceptable manual water level measurements recorded in the field notes. The compensated data will then be downloaded into the project database and plotted and analyzed for abnormalities (e.g., spikes, drops, inconsistencies, fluctuations, etc.).

Comparison:

- a. To justify atypical water level fluctuations, water level data will be compared to precipitation events at Bert Mooney Airport in Butte, Montana.
- b. Trends in water levels will also be compared between nearby monitoring wells and piezometers.
- c. Any discrepancies will be flagged in the data.

4.11.2 Lab Equipment

Instruments used by the laboratory will be maintained in accordance with the laboratory QA plan requirements and analytical method requirements. All analytical measurement instruments and equipment used by the laboratory will be controlled by a formal calibration and preventive maintenance program. The laboratory will keep maintenance records and make them available for review, if requested. Laboratory preventive maintenance will include routine equipment inspection and calibration at the beginning of each day or each analytical batch, per the laboratory internal SOPs and method requirements.

4.12 Inspection/Acceptance of Supplies and Consumables

All supplies and consumables received for the project (e.g., sampling equipment, calibration standards, etc.) will be checked to ensure their condition is satisfactory, such as free of defects that would affect performance. The types of equipment needed to complete sampling activities are described in the relevant field SOPs (Appendix A). Inspections of field supplies will be performed by the Field Team Leader or field team members. The personnel at each laboratory

will be responsible for inspecting laboratory supplies in accordance with the laboratory QA program.

4.13 Data Management Procedures

This section describes how the data for the project will be managed, including field and laboratory data. Data will be managed in accordance with the *BPSOU Data Management Plan* (Atlantic Richfield Company, 2017).

The BRW Phase III QAPP quality records will be maintained by Atlantic Richfield Company. These records, in either electronic or hard copy form, may include the following:

- Project work plans with any approved modifications, updates, and addenda.
- Project QAPP with any approved modifications, updates, addenda, and any approved corrective or preventative actions.
- Field documentation (including logbooks, data sheets, and photographs) in accordance with SOP-SA-05 in Appendix A.
- Chain of custody records in accordance with SOP-SA-04 in Appendix A.
- Field forms, which are provided in Appendix B.
- Laboratory documentation (results received from the laboratory will be documented in hard copy and in an electronic format).
- PDI Evaluation Report.

Hard copy field and laboratory records will be maintained in the project's central data file, where original field and laboratory documents are filed chronologically for future reference. These records will also be scanned to produce electronic copies. The electronic versions of these records will be maintained on a central Microsoft structured query language (SQL) server system that is backed up regularly. The data will be stored on the SQL server and a Microsoft Access database will be set up to access the data, which can then be exported to Excel, if necessary, for further graphing and interpretive analysis. Using a Microsoft-based software configuration is widely accepted with support from Microsoft and allows for easy data sharing with most hardware configurations.

All field and laboratory data and supporting documentation will be subject to appropriate review to ensure the accuracy and completeness of original data records prior to uploading into the project database. Field data that have been reviewed and approved in a hard copy format will be entered into an electronic system to be uploaded to the project database. Laboratory electronic data deliverables (EDDs) provided in Microsoft Excel format and correlating PDF full data packages will be reviewed as part of the internal data review process. Following these review steps, field and laboratory electronic data files will be imported to the project database.

Standardized data import formats and procedures will be used to upload both field and laboratory data into the electronic database. Standardized parameter names, numerical formats, and units of measure will be applied to the original information to facilitate comparability across all data sets and within the database. Using these standardized formats will allow for quick and easy querying

to retrieve data. Data can be retrieved by exporting into an Excel file and, because the data will be formatted with parameter names, easily made into a pivot table for data processing.

5.0 ASSESSMENT AND OVERSIGHT

Assessment and oversight of data collection and reporting activities are designed to verify that sampling and analyses are performed in accordance with the procedures established in this BRW Phase III QAPP. The audits of field and laboratory activities include two independent parts: internal and external audits. Internal audits will be performed by Atlantic Richfield, their contractor, or a contracted laboratory consultant, as necessary. External audits will be performed by EPA, as necessary. Performance and systems audits of field and laboratory data collection and reporting procedures are described in this section.

5.1 Field Activities Oversight

Oversight personnel will have the ability to inspect each soil boring and determine the appropriateness of the recorded data and ensure that the appropriate samples are collected. Copies of field logbook pages will be provided to oversight personnel as part of the PDI Evaluation Report.

Any deviations from this BRW Phase III QAPP will be brought to the attention of oversight personnel. If the deviation is first determined by oversight personnel, Atlantic Richfield and/or field representatives will be immediately notified. Reasons for such deviations will be recorded in the field logbook along with corrective actions to be implemented, if required. If oversight personnel request a deviation from the BRW Phase III QAPP, the deviation and the reasons for the deviation will be noted and then signed by the agency personnel.

5.2 Corrective Action Procedures

Corrective action is the process of identifying, recommending, approving, and implementing measures to counter unacceptable procedures or out-of-QC performance, which can affect data quality. Corrective action can occur during field activities, laboratory analyses, and data assessment.

Non-conforming equipment, items, activities, conditions, and unusual incidents that could affect data quality and attainment of the project's quality objectives will be identified, controlled, and reported in a timely manner. For the BRW Phase III QAPP, a non-conformance is defined as a malfunction, failure, deficiency, or deviation that renders the quality of an item unacceptable or indeterminate in meeting the project's quality objectives. Corrective actions implemented by field personnel will follow appropriate field SOPs (Appendix A), as necessary.

Corrective action in the laboratory may occur prior to, during, and after initial analyses. A number of conditions such as broken sample containers, preservation or holding-time issues, and potentially high-concentration samples may be identified during sample log in or just prior to analyses. Corrective actions to address these conditions will be taken in consultation with the CPM (Section 7.0) and reported on a Corrective Action Report (CAR) form included in

Appendix D, as necessary. In the event that corrective action requests are not in complete accordance with approved project planning documents, EPA will be consulted and concurrence will be obtained before the change is implemented.

If during sample analyses, the associated laboratory QC results fall outside of the project's performance criteria, the laboratory should initiate corrective actions immediately. If laboratory QC results are outside of the project specifications, the laboratory should take the appropriate corrective actions for the specific analytical method. Following consultation with laboratory analysts and section leaders, it may be necessary for the CPM to approve implementing a corrective action. These conditions may include dilution of samples, additional sample extract cleanup, or automatic reanalysis when certain QC criteria are not met. If the laboratory cannot correct the situation that caused the non-conformance and an out-of-control situation continues to occur or is expected to occur, then the laboratory will immediately contact the CPM and request instructions regarding how to proceed with sample analyses.

Completion of any corrective action should be evidenced by data once again falling within the project's performance criteria. If this is not the case, and an error in laboratory procedures or sample collection and handling procedures cannot be found, the results will be reviewed by the CPM and Field Team Leader in consultation with the Contractor QAO to assess whether reanalysis or resampling is required.

All corrective actions taken by the laboratory will be documented in writing by the Laboratory Project Manager and reported to the Field Team Leader and CPM. In the event that corrective action requests are not in complete accordance with approved project planning documents, EPA will be consulted and concurrence will be obtained before the change is implemented. All corrective action records will be included with the QAPP records.

5.3 Corrective Action During Data Assessment

During data assessment, the Contractor QAO could identify the need for corrective action. Potential types of corrective action include re-sampling by the field team, reanalyzing samples by the laboratory, or resubmitting full data packages with corrected clerical errors. The appropriate and feasible corrective actions will depend on the ability to mobilize the field team and whether the data to be collected are necessary to meet the required QA objectives (e.g., the holding time for samples is not exceeded, etc.). If corrective action requests are not in complete accordance with approved project planning documents, EPA will be consulted and concurrence will be obtained before the change is implemented. Corrective actions of this type will be documented by the Contractor QAO on a CAR and will be included in any subsequent reports.

5.4 Quality Assurance Reports to Management

After the investigation is complete, the Atlantic Richfield contractor will incorporate the results into the BRW PDI Evaluation Report summarizing and interpreting the sampling activities. The report will include the following:

- Summary of the investigations performed.

- Summary of investigation results.
- Summary of validated data (i.e., tables and graphics).
- Data validation reports and laboratory data reports.
- Narrative interpretation of data and results.
- Results of statistical and modeling analyses.
- Photographs documenting the work conducted.
- Conclusions and recommendations for RD, including design parameters and criteria.
- Recommendations for an additional phase(s) (if necessary).

The CPM and Contractor QAO are responsible for preparing the PDI Evaluation Report. All Site investigations will be incorporated into the report as the design progresses, and the report will be submitted in draft final form to EPA and Montana DEQ for review approximately 30 days prior to the Intermediate 60% RD Report for the Site.

6.0 HEALTH AND SAFETY

All work completed by Pioneer and its subcontractor during execution of the Phase III Site Investigation will be performed in accordance with all procedures outlined in the BRW Site-SSHASP. Planned field activity for Phase III maintains the same types of activity in Phase II; therefore, the BRW SSHASP currently contains applicable hazards for Phase III. The BRW SSHASP may be updated to include unique hazards that materialize during field activities for the Phase III Site Investigation.

7.0 PROJECT ORGANIZATION AND RESPONSIBILITIES

The roles, duties, and responsibilities of personnel assigned to the Phase III Site Investigation are provided below. An organizational chart showing the overall organization of the project team is detailed on Figure 9.

Atlantic Richfield Company Liability/Project Manager (PM) – Josh Bryson

The Atlantic Richfield Operations PM communicates directly to the Agencies on project matters, monitors the performance of the contractor(s), consults with the CPM and Contractor QAO on deficiencies and helps finalize resolution actions.

Atlantic Richfield Company Quality Assurance Manager (QAM) – David Gratson

The Atlantic Richfield QAM interfaces with the Atlantic Richfield Operations PM on company policies regarding quality and has the authority and responsibility to approve specific QA documents including this BRW Phase III QAPP.

Contractor

Pioneer is the Contractor responsible for conducting the elements of the Phase III Site Investigation under the direction of Atlantic Richfield.

Pioneer Contractor Project Manager (CPM) – Karen Helfrich

The CPM is responsible for scheduling all testing and sampling work to be completed and ensuring that the work is performed in accordance with the requirements contained herein. The CPM, or designated alternate, is also responsible for consulting with the specific project QA personnel regarding any deficiencies and finalizing resolution actions, maintaining the BRW Phase III QAPP, and verifying effective implementation of BRW Phase III QAPP requirements and procedures, including RFCs. This includes reviewing field and laboratory data and evaluating data quality.

Contractor Quality Assurance Officer (QAO) – Thomas Brown

The Contractor QAO is responsible for verifying effective implementation of BRW Phase III QAPP requirements and procedures, including reviewing field and laboratory data, and evaluating data quality. The Contractor QAO may conduct Site reviews and prepare Site review reports for the QAM. The Contractor QAO will have a direct line of communication to the QAM to ensure issues related to project QA are resolved.

The Contractor QAO is also authorized to stop work if, in the judgment of that individual, the work is performed contrary to or in the absence of prescribed QCs or approved methods and further work would make it difficult or impossible to obtain acceptable results.

Pioneer Field Team Leader – Kendra Jackson

The Field Team Leader ensures that the BRW Phase III QAPP and associated RFCs have been reviewed by all members of the field team and the BRW Phase III QAPP procedures are properly followed during field activities. The Field Team Leader will conduct daily safety meetings, assist in field activities, and document activities in the field logbook. The Field Team Leader is responsible for facilitating field activities and managing equipment and is responsible for coordinating with the CPM and Contractor QAO regarding problem solving and decision making in the field. The Field Team Leader is responsible for technical aspects of the project and providing “on-the-ground” overviews of project implementation by observing Site activities to ensure compliance with technical project requirements and the BRW SSHASP. The Field Team Leader is responsible for identifying potential Integrity Management issues during field activities and reporting any issues to the Contractor QAO.

Safety and Health Manager – Tara Schleeman

The Safety and Health Manager is responsible for reviewing the BRW SSHASP with all members of the field team and updating it if necessary. The Safety and Health Manager will lead applicable Task Risk Assessments and conduct the initial safety meeting prior to starting fieldwork. The Safety and Health Manager will monitor work crews’ compliance with all Site safety and health requirements.

7.1.1 Subcontractors

Multiple contractors will assist with the BRW Phase III Site Investigation activities. These companies will subcontract to Pioneer and follow all health and safety protocols established by Pioneer to work on the Site. These subcontractors have been selected due to their unique skillset and specialized equipment.

O’Keefe Drilling (O’Keefe) or an equivalent contractor. O’Keefe, or an equivalent contractor approved by Atlantic Richfield, will supply the rotary sonic drill rig, hollow stem auger rig, and personnel to drill select boreholes (Table 7).

Hunter Brothers Construction (Hunter) or an equivalent contractor. Hunter, or an equivalent contractor approved by Atlantic Richfield, will provide general services for Site investigation activities, such as handling hydrocarbon-impacted soil and water and identifying the location of utilities prior to ground disturbance activities.

7.1.2 Laboratory

The laboratories selected to analyze the soil and groundwater samples will be Atlantic Richfield-approved laboratories that are in general accordance with EPA CLP SOW for Superfund Analytical Methods SFAM01.1 (EPA, 2020b). Eurofins TestAmerica and the Montana Bureau of Mines and Geology (MBMG) were selected to provide analytical services. The MBMG will only provide analysis for radon samples, whereas Eurofins TestAmerica will provide analysis for all other applicable groups in Table 6. Eurofins TestAmerica is required to generate and report high quality data that identify and define the physical and chemical characteristics of soil and groundwater for environmental investigations, remediation activities, long-term monitoring programs, discharge compliance monitoring, and waste characterization under the purview of RCRA and Comprehensive Environmental Response, Compensation & Liability Act (CERCLA), referred to as Superfund. As such, analytical data must be accurately and precisely generated and reported in conformance with the applicable method “best industry standards.”

Geotechnical samples for moisture content, resistivity, pH, sulfate, particle size distribution, Atterberg Limits, standard proctor and/or California Bearing Ration will be analyzed by Pioneer’s Material Testing Laboratories.

The selected laboratories will have QA personnel familiar with the approved QAPP and be responsible for reviewing final analytical reports, scheduling analyses, and supervising in-house custody procedures.

8.0 DATA VALIDATION AND USABILITY

This section addresses the final project checks conducted after the data collection phase of the project is completed to confirm that the data obtained meet the project objectives and to estimate the effect of any deviations on data usability for the express purposes of achieving the stated DQOs (Section 3.0). Based on a review of EPA guidance, the analytical data (not including any geotechnical data) collected will undergo Stage 2A data validation as defined in EPA *Guidance for Labeling Externally Validated Laboratory Analytical Data for Superfund Use* (EPA, 2009). Official XRF analysis data as described in Section 4.8.1 will undergo Stage 2B data validation (EPA, 2009).

8.1 Data Review, Verification, and Validation

This section describes the review, verification, and validation process for field data and laboratory data. The section also details laboratory data reporting requirements, which describe how results are conveyed to data users.

8.1.1 Data Review Requirements

Data review is performed by the data producer to ensure that the data have been recorded, transmitted, and processed correctly.

8.1.1.1 Field Data Review

Raw field data will be entered in field logbooks and/or field data sheets per appropriate field SOPs (Appendix A), and the data will be reviewed for accuracy and completeness by the Field Team Leader before the records are considered final. The overall quality of the field data from any given sampling round will be further evaluated during the process of data reduction and reporting.

Field data reduction procedures will be minimal in scope compared to those implemented in the laboratory setting. Field data review will include verification that any QC checks and calibrations, if necessary, are recorded properly in the field logbooks and/or data sheets and that any necessary and appropriate corrective actions were implemented and recorded. Such data will be written into the field logbook and/or data sheets immediately after measurements are taken. If errors are made, results will be legibly crossed out, initialed, and dated by the field member, and corrected in a space adjacent to the original (erroneous) entry. Later, the Field Team Leader will proof the field logbooks and/or data sheets to determine whether any transcription errors have been made by the field crew. If transcription errors have been made, the Field Team Leader and field crew will address the errors to provide resolution.

If appropriate, field measurement data will be entered into electronic files for import to the project database. Data entries will be made from the reviewed field data sheets or logbooks, and all data entries will be reviewed for accuracy and completeness before the electronic file is provided to the database manager. Electronic files of field measurement data will be maintained as part of the project's quality records.

8.1.1.2 Laboratory Data Review

Internal laboratory data reduction procedures will be according to each laboratory's quality management plan. At a minimum, paper records will be maintained by the analysts to document sample identification number and the sample tag number with sample results and other details, such as the analytical method used (e.g., method SOP #), name of analyst, the date of analysis, matrix sampled, reagent concentrations, instrument settings, and the raw data. These records will be signed and dated by the analyst. Secondary review of these records by laboratory personnel will take place prior to final data reporting to Atlantic Richfield. The laboratory will appropriately flag unacceptable data in the data package.

8.1.2 Data Verification Requirements

Data verification is the process for evaluating the completeness, correctness, and conformance/compliance of a specific data set against the method, procedural, or contractual specifications.

8.1.2.1 Field Data Verification

The Level A/B review, as described in the CFRSSI DM/DV Plan (ARCO, 1992c) and the *CFRSSI DM/DV Plan Addendum* (AERL, 2000), will be used in the verification process for field documentation related to samples collected for laboratory analysis.

The Level A criteria are:

- Sampling date.
- Sample team and/or leader.
- Physical description of sample location.
- Sample depth (soil).
- Sample collection technique.
- Field preservation technique.
- Sample preservation technique.
- Sample shipping records.

The Level B criteria are:

- Field instrumentation methods and standardization complete.
- Sample containers preparations.
- Collection of field duplicates.
- Proper and decontaminated sampling equipment.
- Field custody documentation.
- Shipping custody documentation.
- Traceable sample designation number.
- Field notebook(s), custody records in secure repository.
- Complete field forms.

8.1.2.2 Laboratory Data Verification

The laboratory will prepare standard data packages for transmittal of results and associated QC information to Atlantic Richfield or its designee within a standard turnaround time, unless otherwise required.

The laboratory will prepare standard data packages in general accordance with the EPA CLP SOW for Superfund Analytical Methods SFAM01.1 (EPA, 2020b). Deviations from these specifications should be acceptable provided the report presents all the requested types of information in an organized, consistent, and readily reviewable format.

Each data package, as described above, will be accompanied by an EDD prepared by the laboratory. Additional laboratory QC data can be included in the EDD. The EDDs will be cross checked against corresponding data reports to confirm consistency in results reported in these two separate formats. This cross check will take place as part of the data verification process.

The data packages from the laboratory will contain the following minimum information:

- A narrative addressing any anomalies encountered during sample analysis, and a discussion of any exceedances in the laboratory QC sample results.
- Analytical method references.
- Definition of any data flags or qualifiers used.
- Chain of custody documentation signed and dated by the laboratory to indicate sample receipt.
- Method detection limits and reporting limits.
- Analytical results for each field sample.
- QC sample results (as applicable).

8.1.2.3 Resolution of Deficiencies

Any deficiencies found during the verification process will be discussed with the data producer and may be resolved with a revised data package.

8.1.3 Data Validation Requirements

Data validation is the process of ensuring data are correct and useful. Data validation will be performed by qualified, independent data validation personnel, who are not associated with data collection or sampling responsibilities, and that have applicable training. The QC criteria used during the data validation process will follow the *National Functional Guidelines for Inorganic Superfund Methods Data Review* (EPA, 2020c), the *National Functional Guidelines for Organic Superfund Methods Data Review* (EPA, 2020d), the *National Functional Guidelines for High Resolution Superfund Methods Data Review* (EPA, 2020e), the CFRSSI QAPP (ARCO, 1992b), the CFRSSI DM/DV Plan (ARCO, 1992c), the CFRSSI DM/DV Plan Addendum (AERL, 2000), laboratory-specific QC criteria, and/or method-specific criteria where applicable.

8.2 Verification and Validation Methods

The Level A/B Assessment checklists included in Appendix E are based on the CFRSSI DM/DV Plan Addendum (AERL, 2000) guidance.

Stage 2A Verification and Validation checks include an evaluation of the following, as applicable for each analytical method:

- Completeness of laboratory data package
- Requested analytical methods performed
- Holding times
- Reported detection limits
- Dilution factors
- MBs
- LCS and LCSD
- MS samples and MSDs
- PDSs (as required by the analytical method)
- LDSs
- Field blanks
- Field duplicates
- Serial Dilution (when provided in the laboratory report)

Data qualifiers will follow those used in the National Functional Guidelines for Inorganic Superfund Methods Data Review (EPA, 2020c), the National Functional Guidelines for Organic Superfund Methods Data Review (EPA, 2020d), and the National Functional Guidelines for High Resolution Superfund Methods Data Review (EPA, 2020e). Data validation for each laboratory data package will be documented on the data validation checklists in Appendix E.

The Data Validator will be responsible for reviewing field documentation associated with sample collection, conducting the verification and validation of laboratory-produced data, and completing a data validation report, which will be reviewed by the CPM.

8.3 Reconciliation and User Requirements

The Data Quality Assessment (DQA) process described in the CFRSSI DM/DV Plan Addendum (AERL, 2000) and the Guidance for Data Quality Assessment EPA QA/G-9 (EPA, 2000) will be performed to determine whether project-specific DQOs have been satisfied. The DQA process consists of five steps that relate the quality of the results to the intended use of the data:

- Step 1: Review DQOs and sampling design.
- Step 2: Conduct preliminary data review.
- Step 3: Select statistical test(s), as appropriate, to evaluate data quality.
- Step 4: Verify assumptions.
- Step 5: Draw conclusions about the quality of the data (data report will not include interpretation of results but will state conclusions regarding the quality of the results).

If, as a result of the DQA process, it is determined that data do not satisfy all DQOs, then corrective action(s) should be recommended. Corrective actions include, but are not limited to, revision of the DQOs based on the results of the investigation or collection of more information or data. It may be determined that corrective actions are not required or the decision process may continue with the existing data, with recognition of the limitations of the data.

The PARCCS data quality indicators (Section 3.1) will be used when conducting the DQA. If the PARCCS assessment satisfies the project DQOs, then usability of the data will follow the enforcement/screening/unusable data categories as described in the CFRSSI DM/DV (ARCO, 1992c):

1. Enforcement Quality (Unrestricted Use) Data

Enforcement quality data may be used for all purposes under the Superfund program including the following: site characterization, health and safety, Environmental Evaluation/Cost Analysis, remedial investigation/feasibility study, alternatives evaluation, confirmational purpose, risk assessment, and engineering design.

2. Screening Quality (Restricted Use) Data

Potential uses of screening quality data, depending upon their quality, include site characterization, determining the presence or absence of contaminants, developing or refining sampling and analysis techniques, determining relative concentrations, scoping and planning for future studies, engineering studies and engineering design, and monitoring during implementation of the response action.

3. Unusable Data

These data are not useable for Superfund-related activities.

Data that meet the Level A and Level B criteria and are not qualified as estimated or rejected during the data validation process are assessed as enforcement quality data and can be used for all Superfund purposes and activities. Data that meet only the Level A criteria and are not rejected during the data validation process can be assessed as screening quality data. Screening quality data can be used only for certain activities, which include engineering studies and design. Data that do not meet the Level A and/or B criteria and/or are rejected during the data validation process are designated as unusable. The data are assigned one of the following qualifiers:

- E = Enforcement quality. No qualifiers or U qualifier and meets Level A and B criteria.
- S = Screening quality. J or UJ qualifier and/or meets only Level A criteria.
- R = Unusable. R qualifier and/or does not meet Level A or B requirements.

Enforcement/Screening Designation

	Meets Level A and B	Meets Level A	Does not meet Level A or B
No qualifier, A, or U	E	S	R
J, J+, J-, or UJ	S	S	R
R	R	R	R

9.0 REFERENCES

- AERL, 2000. Clark Fork River Superfund Site Investigations (CFRSSI) Data Management/Data Validation Plan Addendum.
- ARCO, 1992a. Clark Fork River Superfund Site Investigation, Laboratory Analytical Protocol. Prepared by PTI Environmental Services, April 1992.
- ARCO, 1992b. Clark Fork River Superfund Site Investigation Quality Assurance Project Plan. Prepared by PTI Environmental Services May 1992.
- ARCO, 1992c. Clark Fork River Superfund Site Investigation (CFRSSI) Data Management/Data Validation Plan, Prepared by PTI Environmental Services, Contract C 117-06-64, April 1992.
- ARCO, 1992d. Clark Fork River Superfund Site Investigations (CFRSSI) Standard Operating Procedures (SOPs). September 1992.
- ASTM, 2017a. ASTM D1586 - 11, Standard Test Method for Standard Penetration Test (SPT), and Split-Barrel Sampling of Soils, ASTM International, West Conshohocken, PA, 2017, www.astm.org
- ASTM, 2017b. ASTM D1587/D1587M - 15, Standard Practice for Thin-Walled Tube Sampling of Fine-Grained Soils for Geotechnical, ASTM International, West Conshohocken, PA, 2017, www.astm.org
- Atlantic Richfield Company, 2016. Final Revised 2011 Blacktail Creek and Silver Bow Creek Radon Tracing and Thermal Imaging Survey Technical Memorandum. Prepared by Pioneer Technical Services, Inc. May 10, 2016.
- Atlantic Richfield Company, 2017. Butte Area NPL Site Butte Priority Soils Operable Unit Final Draft Data Management Plan. Prepared by TREC Inc. December 22, 2017.
- Atlantic Richfield Company, 2018. Silver Bow Creek/Butte Area NPL Site Butte Priority Soils Operable Unit Surface Water Monitoring Quality Assurance Project Plan, 2018.
- Atlantic Richfield Company, 2021a. Silver Bow Creek/Butte Area NPL Site Butte Priority Soils Operable Unit Butte Reduction Works (BRW) Phase I Quality Assurance Project Plan (QAPP) (which includes associated Request for Change documents). Revision 3. Prepared by Pioneer Technical Services, Inc. February 2021.
- Atlantic Richfield Company, 2021b. Silver Bow Creek/Butte Area NPL Site Butte Priority Soils Operable Unit Final Revised Butte Reduction Works (BRW) Smelter Area Mine Waste Remediation and Contaminated Groundwater Hydraulic Control Site 2021 Phase II Quality Assurance Project Plan (which includes associated Request for Change documents). Revision 2. Prepared by Pioneer Technical Services Inc. February 2021.

- Atlantic Richfield Company, 2021c. Silver Bow Creek/Butte Area NPL Site Butte Priority Soils Operable Unit Final Butte Reduction Works (BRW) Smelter Area Mine Waste Remediation and Contaminated Groundwater Hydraulic Control Site Remedial Design Work Plan. Prepared by Pioneer Technical Services Inc. May 13, 2021.
- Atlantic Richfield Company, 2021d. Silver Bow Creek/Butte Area NPL Site Butte Priority Soils Operable Unit Draft Final Revised Butte Reduction Works (BRW) Smelter Area Mine Waste Remediation and Contaminated Groundwater Hydraulic Control Site Pre-Design Investigation (PDI) Evaluation Report. Prepared by Pioneer Technical Services Inc. May 13, 2021.
- Atlantic Richfield Company, 2021e. Silver Bow Creek/Butte Area NPL Site Butte Priority Soils Operable Unit Draft Final Preliminary 30% Remedial Design Report for the Butte Reduction Works (BRW) Smelter Area. Prepared by Pioneer Technical Services, Inc. May 13, 2021.
- DEQ, 2002. Montana Department of Environmental Quality's Geographic Information System Portal. Information search related to Montana Power Storage Yard - Comprehensive Environmental Cleanup and Responsibility Act (CECRA) Site. Site Summary. September 25, 2002. Available at <https://gis.deq.mt.gov/portal/home/>.
- EPA, 2000. Guidance for Data Quality Assessment, Practical Methods for Data Analysis, EPA QA/G-9, QA00 Update. U.S. Environmental Protection Agency, July 2000. Available at <https://www.epa.gov/sites/production/files/2015-06/documents/g9-final.pdf>.
- EPA, 2006. Guidance on Systematic Planning Using the Data Quality Objectives Process (QA/G-4). Washington DC: EPA, Office of Environmental Information. EPA/240/B-06/001. Available at <http://www.epa.gov/quality/qs-docs/g4-final.pdf>.
- EPA, 2009. U.S. Environmental Protection Agency Guidance for Labeling Externally Validated Laboratory Analytical Data for Superfund Use, January 2009.
- EPA, 2017. Five-Year Review Report. Fourth Five-Year Review Report for the Montana Pole and Treating Plant Site. Butte, Silver Bow County, Montana. U.S. Environmental Protection Agency, June 30, 2017. Available at <https://semspub.epa.gov/work/08/1818426.pdf>.
- EPA, 2020a. Consent Decree for the Butte Priority Soils Operable Unit. Partial Remedial Design/Remedial Action and Operation and Maintenance. U.S. Environmental Protection Agency. February 13, 2020. Available at <https://www.co.silverbow.mt.us/2161/ButtePriority-Soils-Operable-Unit-Conse>.
- EPA, 2020b. Contract Laboratory Program (CLP) Statement of Work for Superfund Analytical Methods (Multi-Media, Multi-Concentration) SFAM01.1 U.S. Environmental Protection Agency, November 2020.
- EPA, 2020c. National Functional Guidelines for Inorganic Superfund Methods Data Review, EPA 542-R-20-006. U.S. Environmental Protection Agency, November 2020.

- EPA, 2020d. National Functional Guidelines for Organic Superfund Methods Data Review, EPA 540-R-20-005. U.S. Environmental Protection Agency, November 2020.
- EPA, 2020e. National Functional Guidelines for High Resolution Superfund Methods Data Review, EPA 542-R-20-007. U.S. Environmental Protection Agency, November 2020.
- GCM Services, Inc., 1991. Cultural Resource Inventory of The Lower Area One Operable Unit of Silver Bow Creek/Butte Area NPL Site and the Montana Pole and Treating Plant NPL Site, December 1991.
- Munsell, 2009. Munsell Soil Color Book. 2009 Revision.
- OhioEPA, 2008. Technical Guidance Manual For Ground Water Investigations, Chapter 7 Monitoring Well Design and Installation. February 2008 Revision 1. Ohio Environmental Protection Agency Division of Drinking and Ground Waters.
- Robbins, G.A., Aragon-Jose, A.T., Romero, A., 2009. Determining Hydraulic Conductivity Using Pumping Data from Low-Flow Sampling. Ground Water Volume 47, No. 2. March-April 2009.
- Sanborn, 1943. Map of Survey of Defense Plant Corporation, Domestic Manganese and Development Company and Metals Reserve Tracts and Improvements Theron in the N $\frac{1}{2}$ of SW $\frac{1}{4}$ of Section 24 T 3N, R 8W. Silver Bow County, Montana. Surveyed May 4th to 31st, 1943 by Francis T. Morris, Surveyor.

FIGURES

Figure 1. Site Location Map

Figure 2. Site Map

Figure 3. BRW Smelter Area Conceptual Remedial Action Plan

Figure 4. Additional Phase III Investigation Locations to be Installed

Figure 5. Proposed Piezometer Construction for Stickup Configuration

Figure 6. Additional Samples for SPLP Analysis

Figure 7. Groundwater Characterization Sampling Locations

Figure 8. Silver Bow Creek Loading Analysis Locations

Figure 9. Project Organizational Chart

TABLES

Table 1. Data Gaps Summary

Table 2. Applicable and Relevant Standard Operating Procedures

Table 3. Data Quality Objectives

Table 4. Schedule

Table 5. Precision, Accuracy and Completeness Calculation Equations

Table 6. Sample Collection, Preservation, and Holding Times

Table 7. Phase III Site Investigation Locations

Table 8. Limit of Detection for XRF

Appendix A.

Standard Operating Procedures

Appendix B.

Field Forms and Tables

Appendix C.
Geotechnical Investigation Reference Documents

Appendix D.
Corrective Action Report

Appendix E. Data Validation

FIGURES

Figure 1. Site Location Map

Figure 2. Site Map

Figure 3. BRW Smelter Area Conceptual Remedial Action Plan

Figure 4. Additional Phase III Investigation Locations to be Installed

Figure 5. Proposed Piezometer Construction for Stickup Configuration

Figure 6. Additional Samples for SPLP Analysis

Figure 7. Groundwater Characterization Sampling Locations

Figure 8. Silver Bow Creek Loading Analysis Locations

Figure 9. Project Organizational Chart

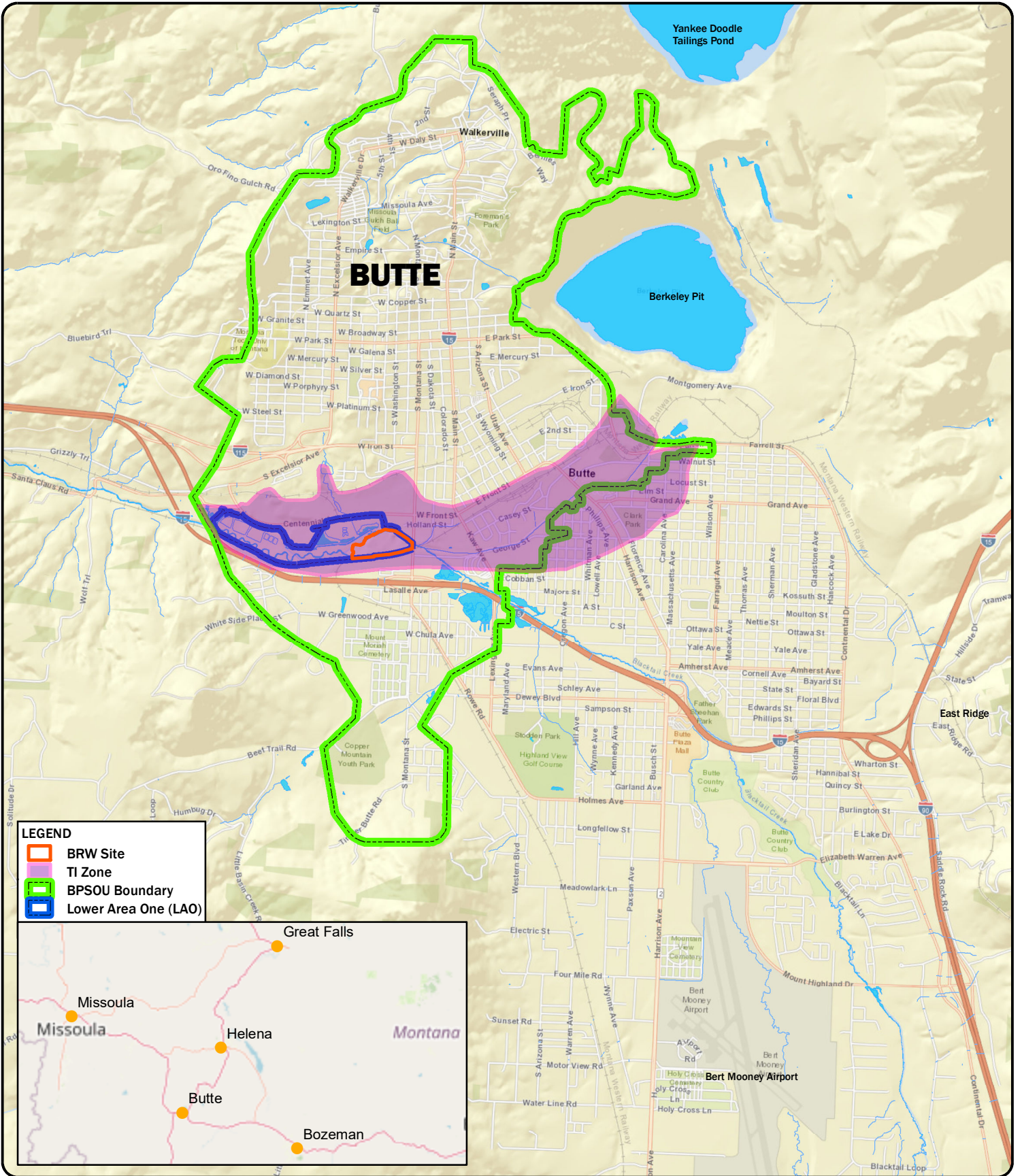

LEGEND

- BRW Site
- TI Zone
- BPSOU Boundary
- Lower Area One (LAO)

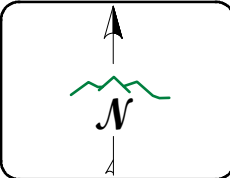
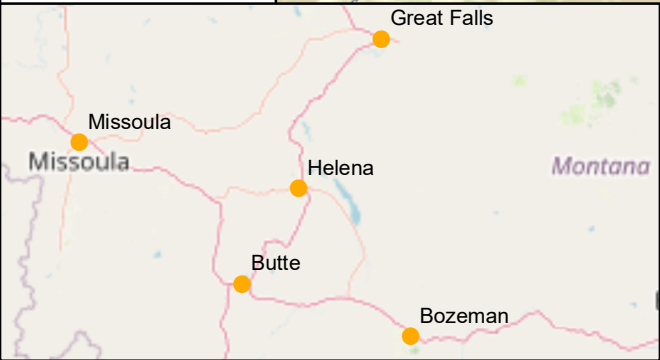

DISPLAYED AS: _____
 PROJECTION/ZONE: MSP _____
 DATUM: NAD_83 _____
 UNITS: INT'L FT _____
 SOURCE: PIONEER/ARCO/BSB _____

0 0.375 0.75 1.5
 Miles

FIGURE 1

SITE LOCATION MAP

Date: 4/11/2022

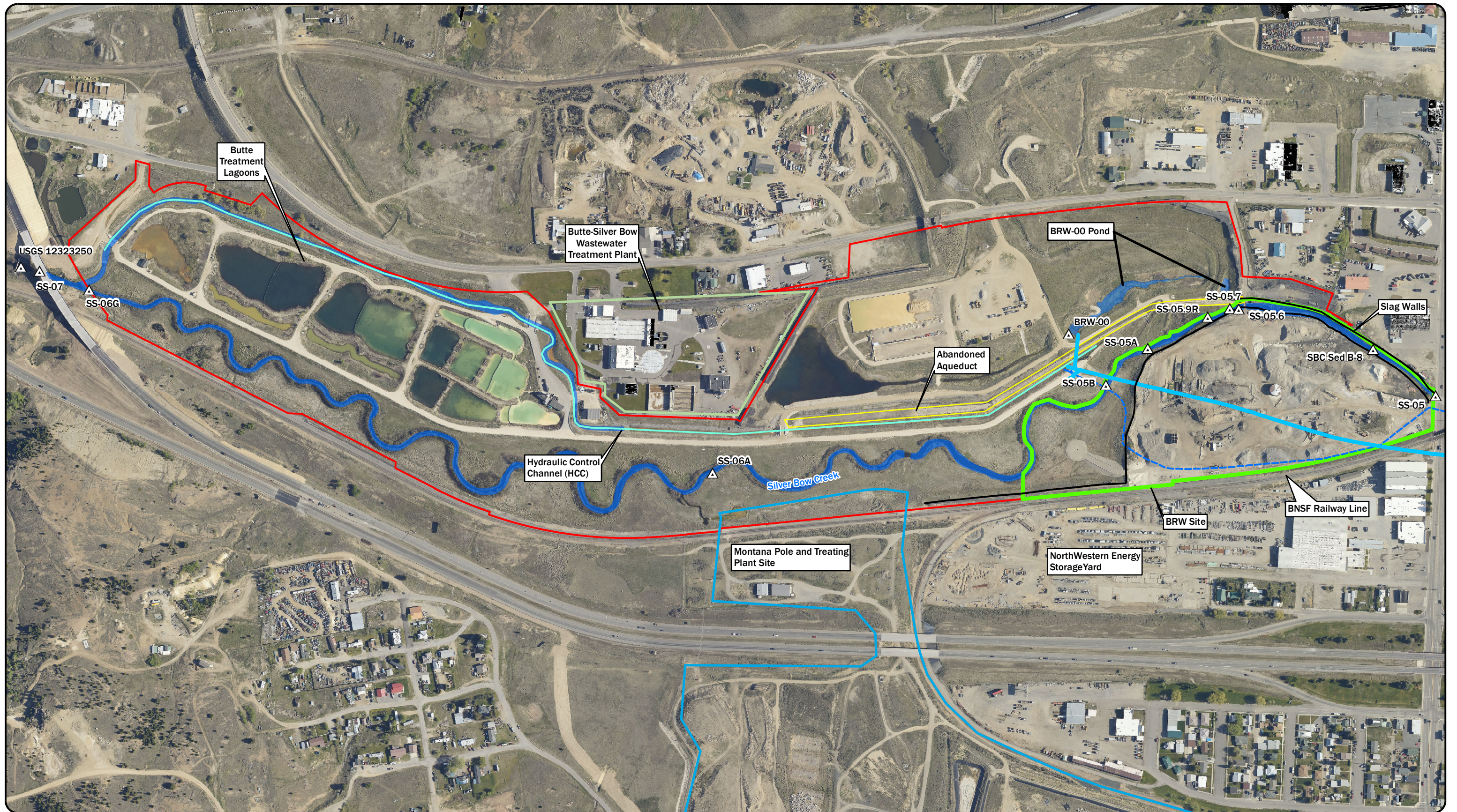

- Surface Water Monitoring Points
- BPSOU Subdrain Pump System Alternate Discharge Line
- Hydraulic Control Channel
- BPSOU Subdrain Pump System Primary Force Main
- Slag Walls
- BRW Site Boundary
- LAO Boundary
- Butte-Silver Bow Wastewater Treatment Plant Boundary
- Abandoned Aqueduct
- MPTP Site Boundary

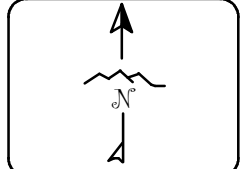

DISPLAYED AS: _____
 PROJECTION/ZONE: MSP _____
 DATUM: NAD 83 _____
 UNITS: INTERNATIONAL FEET _____
 SOURCE: PIONEER/TREC/QSI 2020 _____
 0 200 400 800
 Feet

FIGURE 2
SITE MAP

 DATE: 4/11/2022

THE PROPOSED REMEDY INVOLVES REMOVAL OF TAILINGS, WASTE, IMPACTED SOILS, AND SLAG WITHIN THE STREAM RECONSTRUCTION CORRIDOR (ALSO REFERRED TO AS THE WASTE REMOVAL CORRIDOR) THAT FAILS THE WASTE IDENTIFICATION SCREENING CRITERIA, SPECIFIED IN THE BUTTE PRIORITY SOILS OPERABLE UNIT CONSENT DECREE (BPSOU CD), TO A DEPTH DETERMINED DURING THE REMEDIAL DESIGN; CONSTRUCTION OF A HYDRAULIC CONTROL SYSTEM TO MANAGE GROUNDWATER IMPACTED WITH CONTAMINANTS OF CONCERN (COCs) (I.E., ARSENIC, CADMIUM, COPPER, MERCURY, LEAD, AND ZINC) TO PREVENT EXCEEDANCES OF PERFORMANCE STANDARDS, SPECIFIED IN THE BPSOU CD, UNDER NORMAL FLOW CONDITIONS IN SURFACE WATER AND TO LIMIT LOADING OF COCS FROM GROUNDWATER TO SEDIMENTS IN SILVER BOW CREEK WITHIN THE BPSOU GENERALLY AND WITHIN THE BRW SMELTER AREA SPECIFICALLY; AND RECONSTRUCTION OF SILVER BOW CREEK (SBC) AND THE FLOODPLAIN.

REGRADE AND CONSTRUCT CAP (AS NEEDED): NORTHERN PORTION OF THE SITE (OUTSIDE OF REMOVAL CORRIDOR) SHALL BE CAPPED WITH A MINIMUM ENGINEERED CAP OF 18" IN AREAS WHERE TAILINGS, WASTES, OR CONTAMINATED SOILS ARE LEFT IN PLACE TO ENSURE PROTECTIVENESS OF HUMAN HEALTH AND THE AREA WILL BE REGRADED AS NEEDED TO FACILITATE FUTURE END LAND USES.

RECONSTRUCT SBC: FOLLOWING EXCAVATION WORK AND INSTALLATION OF THE HYDRAULIC CONTROL, SBC AND THE FLOODPLAIN WILL BE RECONSTRUCTED WITHIN THE EXCAVATION FOOTPRINT THROUGH THE BUTTE REDUCTION WORKS SMELTER AREA. THE REALIGNED SBC AND FLOODPLAIN WOULD BE CONSTRUCTED SOUTH OF THE EXISTING SLAG CANYON AND CONNECT WITH SBC AT LOWER AREA ONE.

CONCEPTUAL HYDRAULIC CONTROL: A DRAIN WILL BE INSTALLED TO CONTROL DISCHARGE OF COC-IMPACTED GROUNDWATER INTO RECONSTRUCTED SBC. THIS IS ACHIEVED BY ENSURING A GRADIENT TOWARDS THE DRAIN.

CONCEPTUAL RECONSTRUCTED SBC BANKFULL CHANNEL

EXCAVATION AND DISPOSAL: APPROXIMATELY 250,000 CUBIC YARDS OF TAILINGS, WASTE, CONTAMINATED SOILS, AND SLAG WOULD BE EXCAVATED FROM THE WASTE REMOVAL CORRIDOR, THEN HAULED TO AN APPROVED REPOSITORY FOR DISPOSAL. THE EXCAVATION FOOTPRINT WOULD BE AN AVERAGE OF 275 FEET WIDE AND APPROXIMATELY 1,800 FEET LONG. THE FINAL DEPTH, REMOVAL VOLUME AND FOOTPRINT LOCATION WILL BE DETERMINED DURING THE DESIGN PHASE OF THE PROJECT.

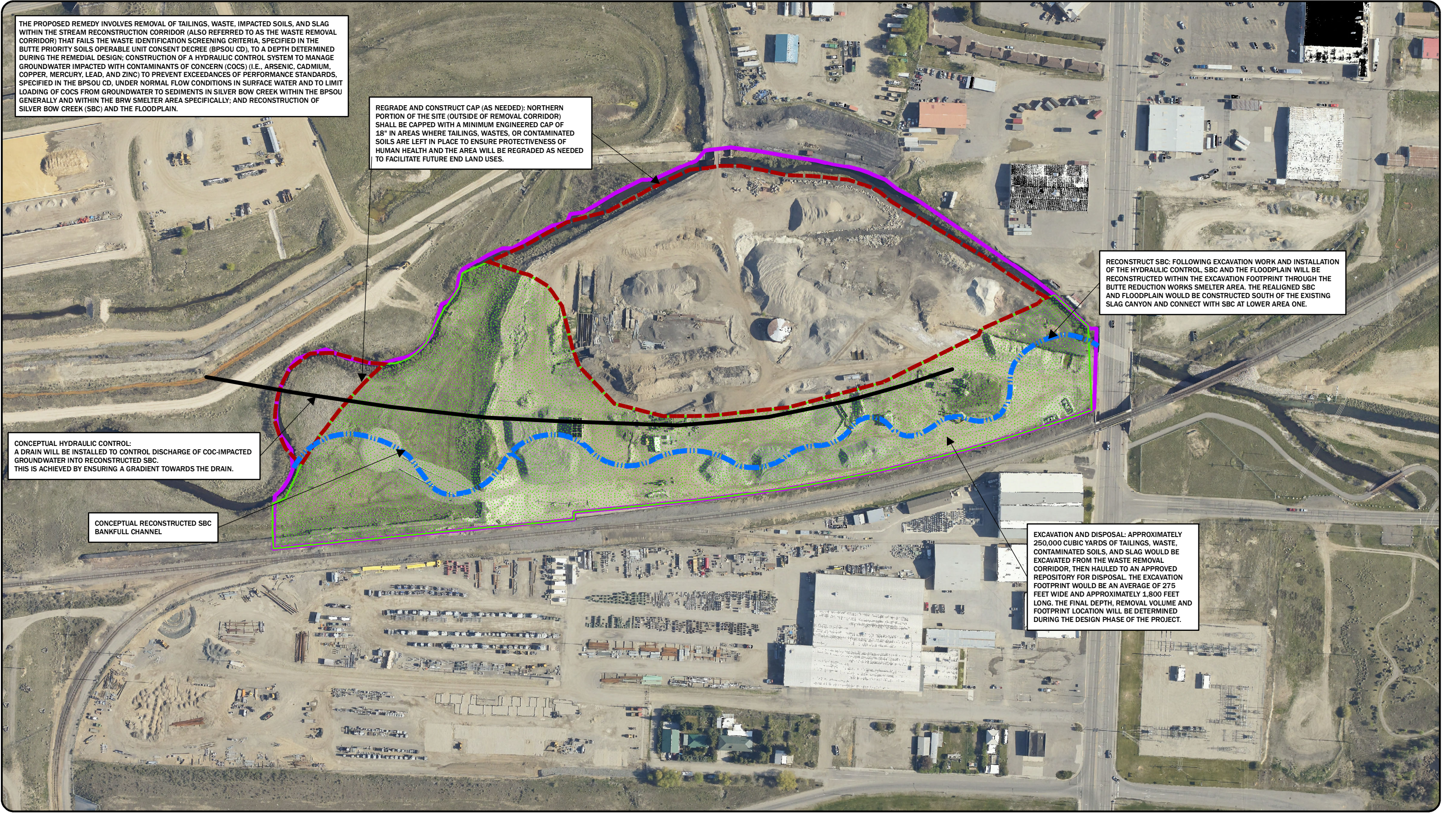

- LEGEND**
- Engineered Cap
 - Conceptual Hydraulic Control
 - Preliminary Waste Removal Corridor
 - Conceptual Reconstructed SBC
 - BRW Site Boundary

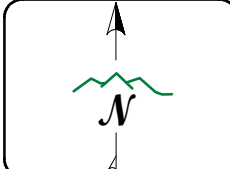

DISPLAYED AS: _____
 PROJECTION/ZONE: MSP
 DATUM: NAD 83
 UNITS: INT'L FT
 SOURCE: PIONEER/GSI 2020

FIGURE 3

**BRW SMELTER AREA
 CONCEPTUAL REMEDIAL
 ACTION PLAN**

DATE: 6/8/2022

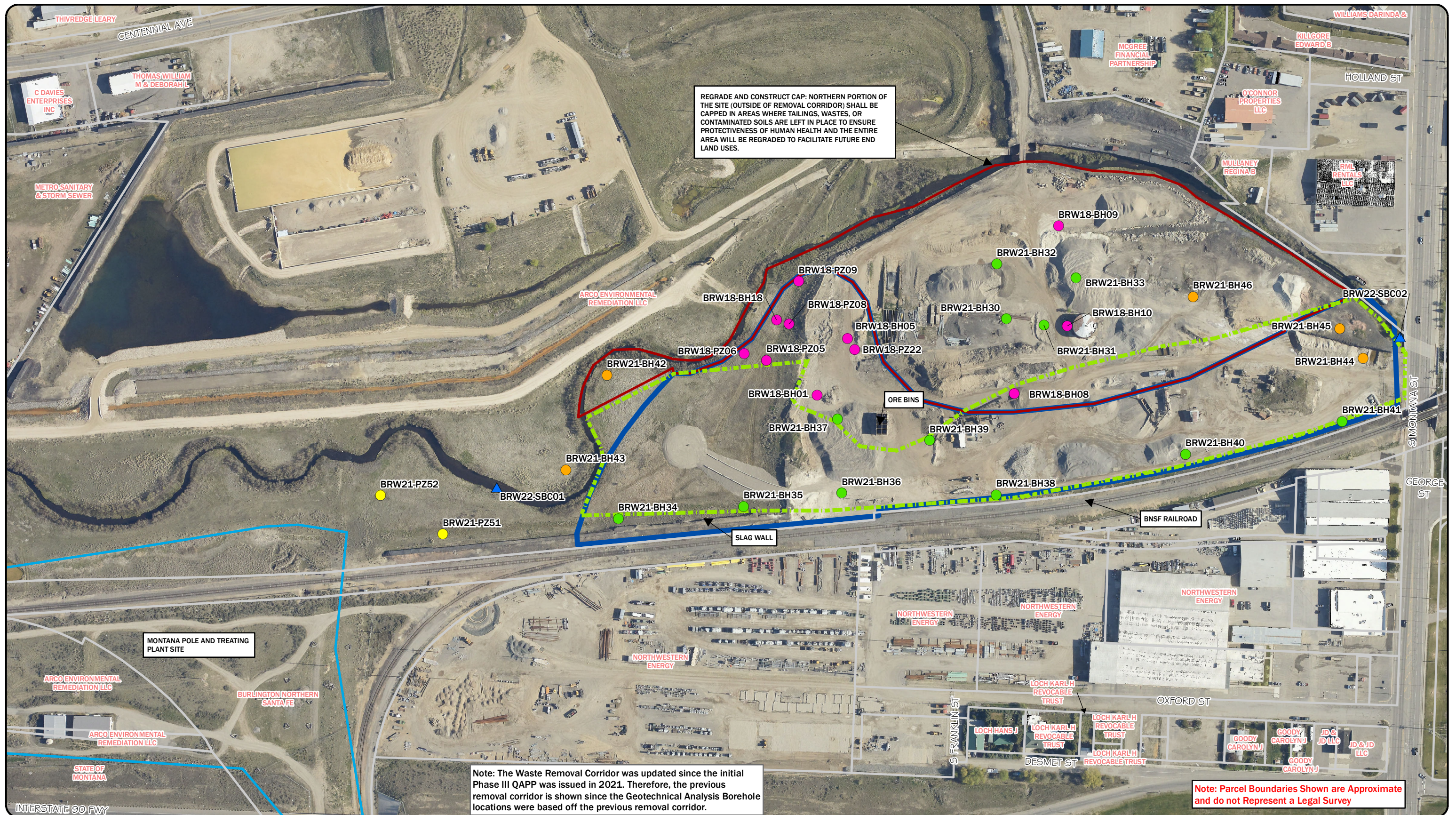

- Waste Characterization Borehole
- Geotech Analysis Borehole
- Phase III Piezometer*
- Proposed Samples for Additional SPLP Analysis
- ▲ Proposed Stream Sediment Sample
- Conceptual Cap Area Boundary
- Preliminary Waste Removal Corridor (30% Remedial Design)
- Preliminary Waste Removal Corridor
- MPTP Site Boundary
- Approximate Owner Parcel Boundary

*Solid material characterization information collected during the installation of the Phase III Piezometers will be used only to inform the design of the BRW hydraulic control.

Note: The Waste Removal Corridor was updated since the initial Phase III QAPP was issued in 2021. Therefore, the previous removal corridor is shown since the Geotechnical Analysis Borehole locations were based off the previous removal corridor.

Note: Parcel Boundaries Shown are Approximate and do not Represent a Legal Survey

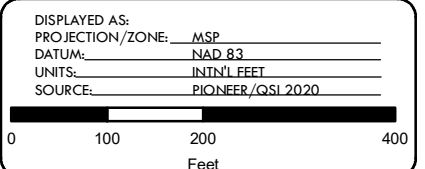
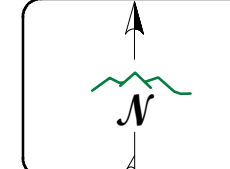
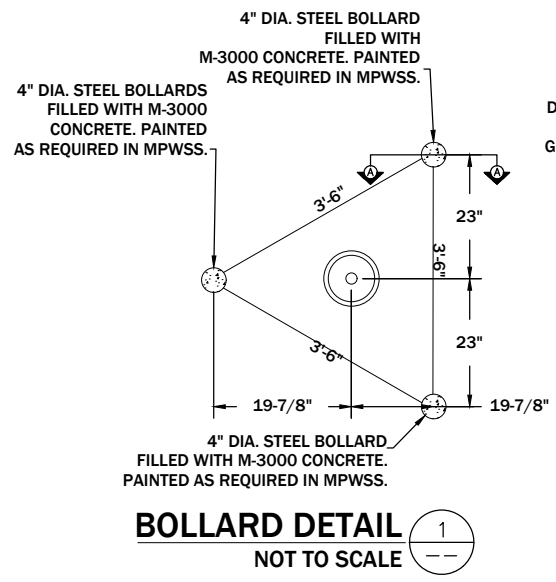
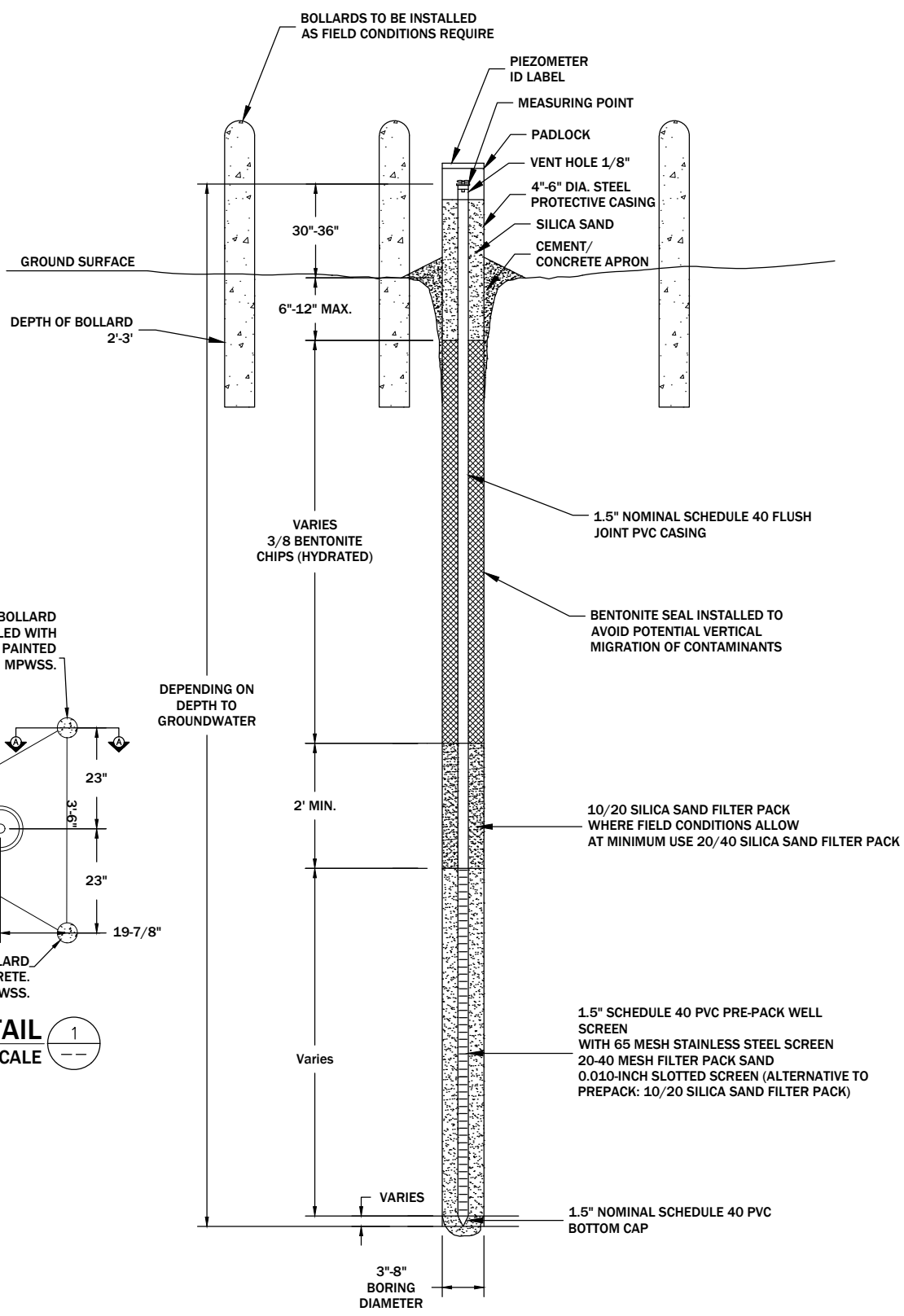

FIGURE 4
ADDITIONAL PHASE III INVESTIGATION LOCATIONS TO BE INSTALLED

DATE: 4/22/2022



DISPLAYED AS: _____
 COORD SYS/ZONE: N/A
 DATUM: N/A
 UNITS: N/A
 SOURCE: PIONEER

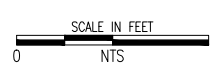

FIGURE 5

**PROPOSED
 PIEZOMETER
 CONSTRUCTION FOR
 STICKUP
 CONFIGURATION**



DATE: 09/2021

Table 2. Proposed Samples for Additional SPLP Analysis

Location	Target Interval (feet below ground surface)
Slag Samples	
BRW18-BH01	15.0 - 16.8
BRW18-BH05	19.5 - 20.9
BRW18-BH08	3.0 - 8.1
BRW18-BH09	1.1 - 2.5
BRW18-BH10	7.8 - 9.5
Leachable Soil Layer near Piezometer BRW18-PZ08	
BRW18-BH01	22.6 - 23.8
BRW18-BH05	20.9 - 21.7
BRW18-BH18	4.1 - 6.1
BRW18-PZ05	4.2 - 6.8
BRW18-PZ06	6.0 - 7.0
BRW18-PZ08	5.5 - 6.6
BRW18-PZ08	7.2 - 8.5
BRW18-PZ09	5.1 - 6.2
BRW18-PZ22	25-26.2

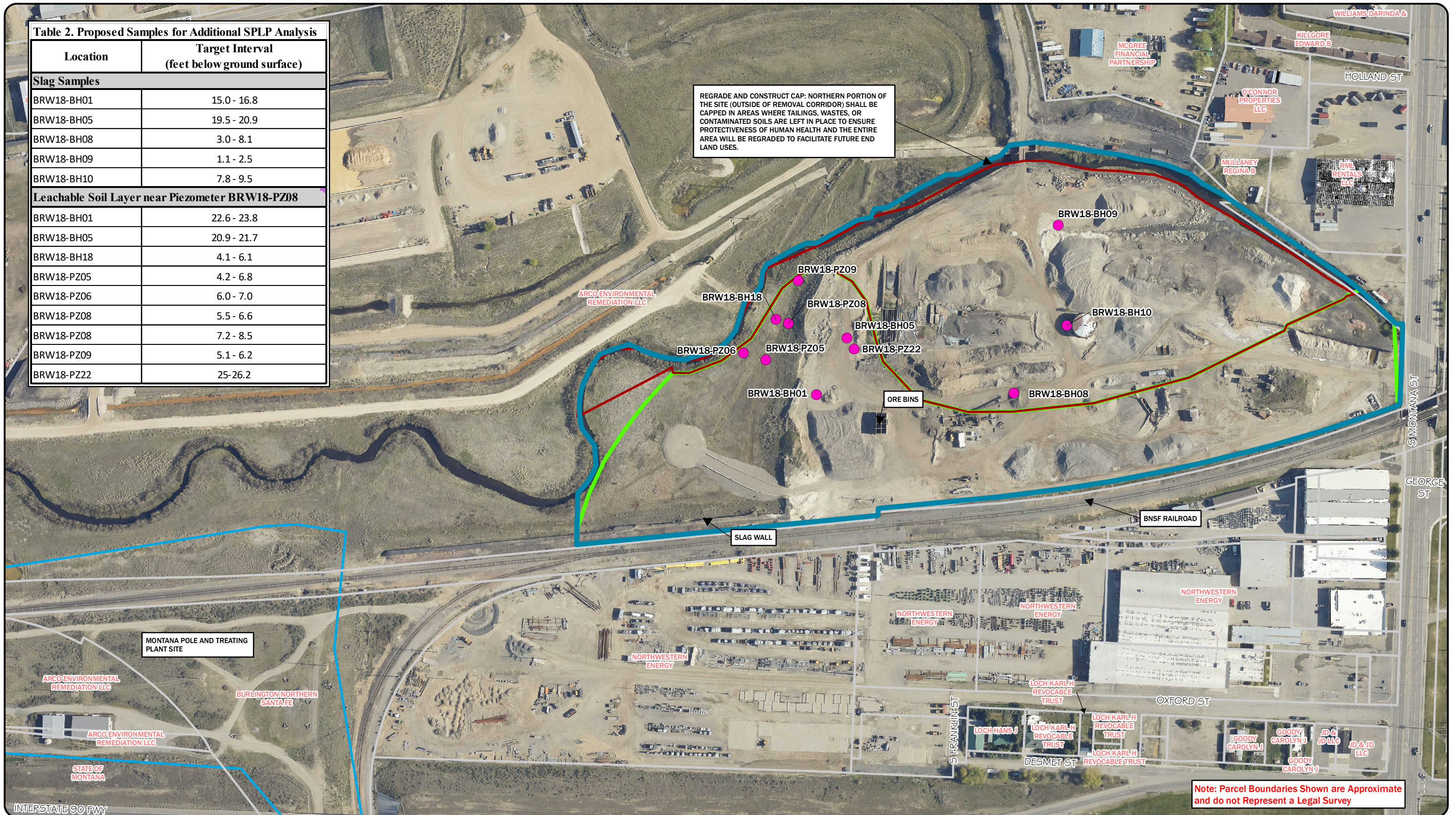

Note: Parcel Boundaries Shown are Approximate and do not Represent a Legal Survey

- Proposed Samples for Additional SPLP Analysis
- MPTP Site Boundary
- BRW Site Boundary
- Preliminary Waste Removal Corridor
- Conceptual Cap Area Boundary
- Approximate Owner Parcel Boundary

Note: These investigation points have already been installed and samples will be collected from archived cores.

Path: Z:\Shared\Active Projects\ARCO\BPSOU\BRW\GIS\I_PhaseII\QAPP\BRW_PIII_QAPP_006_SPLP_22.mxd

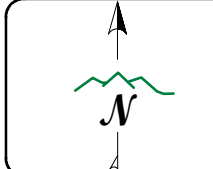

DISPLAYED AS:
 PROJECTION/ZONE: MSP
 DATUM: NAD 83
 UNITS: INT'L FEET
 SOURCE: PIONEER/QSI 2020

FIGURE 6
ADDITIONAL SAMPLES FOR SPLP ANALYSIS

DATE: 4/22/2022



Previously Installed Locations

- ⊕ Proposed Phase III Piezometer*
- ⊕ Existing Monitoring Well
- ⊕ Existing Phase II Piezometer
- ⊕ Existing Phase I Piezometer
- ⊕ Existing Hydrocarbon Piezometer
- MPTP Site Boundary

*Solid material characterization information collected during the installation of the Phase III Piezometers will be used only to inform the design of the BRW hydraulic control.

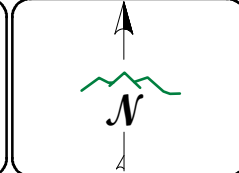

DISPLAYED AS: _____
 PROJECTION/ZONE: MSP
 DATUM: NAD 83
 UNITS: INT'L FEET
 SOURCE: PIONEER/CADSWH 2014

FIGURE 7

GROUNDWATER CHARACTERIZATION SAMPLING LOCATIONS

DATE: 4/11/2022



Note: Groundwater Contours did not use Groundwater Elevations from either FP98-1 or BRW18-PZ03 or Surface Water Elevations from Silver Bow Creek.

● Proposed Phase III Piezometer*
 ● Existing Phase I Piezometer
 ● Existing Monitoring Well
 — Groundwater Contours (May 2019, NAVD 88, 1 Ft Interval)

● Existing Phase II Piezometer
 ▲ Staff Gauge
 Conceptual Removal Area Boundary

*Solid material characterization information collected during the installation of the Phase III Piezometers will be used only to inform the design of the BRW hydraulic control.

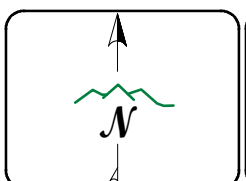

DISPLAYED AS: _____
 PROJECTION/ZONE: MSP
 DATUM: NAD 83
 UNITS: INT'L FEET
 SOURCE: PIONEER/CAD/EARTH 2014

0 125 250 500
Feet

FIGURE 8

**SILVER BOW CREEK
LOADING ANALYSIS
LOCATIONS**

PIONEER
TECHNICAL SERVICES, INC.

DATE: 4/11/2022

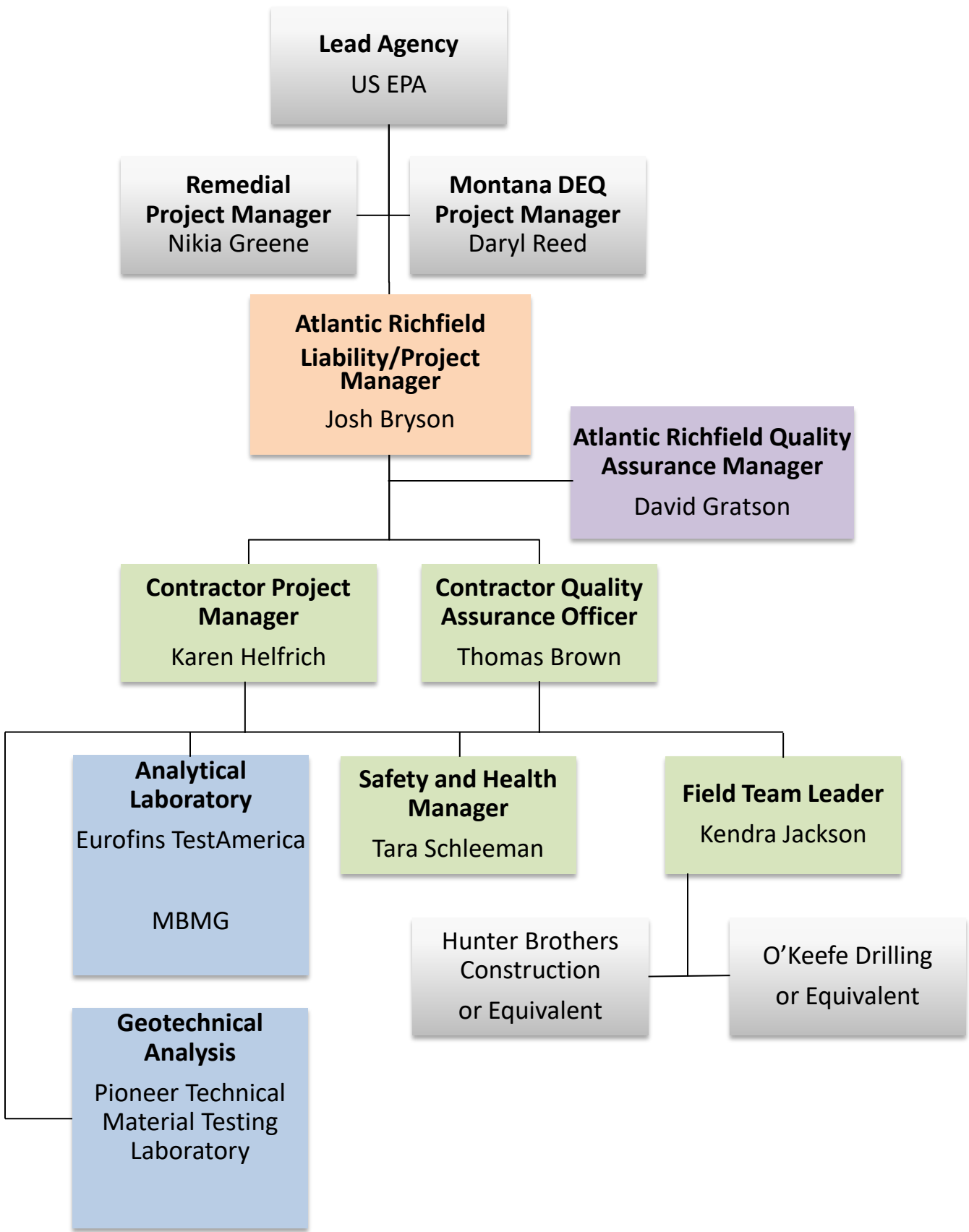

Figure 9



Project Organization Chart

TABLES

Table 1. Data Gaps Summary

Table 2. Applicable and Relevant Standard Operating Procedures

Table 3. Data Quality Objectives

Table 4. Schedule

Table 5. Precision, Accuracy and Completeness Calculation Equations

Table 6. Sample Collection, Preservation, and Holding Times

Table 7. Phase III Site Investigation Locations

Table 8. Limit of Detection for XRF

Table 1. Data Gaps Summary

Data Gap Categories	Objectives	Phase I Site Investigation Additional GWS Sampling	Hydrocarbon Investigation Phase II Site Investigation	Phase III Site Investigation Additional Investigations	Phase I Site Investigation (Phase I QAPP) Additional Groundwater Sampling (Phase I QAPP, RFC 01)	Hydrocarbon Investigation (Phase I QAPP, RFC 03)	Phase II Site Investigation (Phase II QAPP)	Phase III Site Investigation (Phase III QAPP) Supplemental Groundwater and Surface Water Sampling (Phase II QAPP, RFC 01 and RFC 02)	Additional Investigations to Fill Remaining Data Gaps		
Solid Material Characterization	Volume and Distribution of Solid Materials										
	Slag	0	0	✓	+	Laboratory and XRF data, soil lithology logs, and photographic logs from test pits and boreholes were used to determine the volume and distribution of solid materials within the BRW Site.	Laboratory and XRF data, soil lithology logs, and photographic logs from hydrocarbon monitoring well boreholes and test pits were used to augment and refine the volume and distribution of solid materials within the BRW Site.	Laboratory and XRF data, soil lithology logs, and photographic logs from new piezometer boreholes and slag investigation test pits were used to augment and refine the volume and distribution of solid materials within the BRW Site.	A final series of boreholes were constructed. Laboratory and XRF data, soil lithology logs, and photographic logs from boreholes will be used to fill any design-related data gaps pertaining to the volume and distribution of impacted materials within the BRW site.	NA	
	Demolition Debris	✓	+	+	+						
	Impacted Materials (Including Tailings, Alluvium, and Organic Soils)	0	0	0	✓						
	Unimpacted Materials	✓	+	+	+						
	Properties of Solid Materials										
	Metals Concentrations	0	0	0	✓	The test pit and borehole samples were analyzed using an XRF field unit. Select samples were sent for laboratory ICP (metals concentrations) and SPLP analysis (leachability).	Test pit and borehole samples were analyzed using an XRF field unit. Select samples were sent for laboratory ICP (metals concentrations) analyses.	Borehole samples were analyzed using an XRF field unit or sent for laboratory ICP analysis. Select samples were sent for laboratory SPLP (leachability) analyses.	Borehole samples were analyzed using an XRF field unit or sent for laboratory ICP analysis. Select samples were sent for laboratory SPLP (leachability) analyses.	As part of the Microbial Analysis and Bioremediability Study, additional samples from test pits will be sent for metals analysis.	
Leachability of Metals	0		0	0	✓				Additional samples from archived cores will be collected and submitted for SPLP analysis.		
Constructability Considerations	Geotechnical Considerations			0	0	✓	NA	Additional boreholes were drilled during a geotechnical investigation to determine properties of the underlying soil and then the data will be used to evaluate the geotechnical requirements of the end-land use plan and excavation design.	A final geotechnical survey will be performed on the western portion of the site to characterize a clay layer by drilling boreholes and collecting geotechnical samples (i.e., direct shear, gradation, consolidation testing, Atterberg limits).		
	Location of Subsurface Flume/Culvert	✓					+	The geophysical MASW Seismic Survey confirmed the existence and location of the subsurface flume/culvert.	NA	Completion of a primary wave seismic investigation will provide additional data needed to determine if subsurface voids exist within BRW Site where excavation or end-land use structures will be constructed.	
	Remaining Infrastructure	✓					+	Measurements and photographs documented the remaining infrastructure at the BRW Site. Observations from test pits were used to determine the existence of any durable historic infrastructure.	NA		
Groundwater Characterization and Hydraulic Control	Chemistry and Spatial Variability for BPSOU COCs	0	0	0	0	✓		New piezometers were installed, and lithology logs from the piezometer construction and manual groundwater level measurements were used to augment and refine the aquifer geometry.			
	Conductivity and Transmissivity (Impacted Groundwater Volume)	0	0	0	✓	+	Laboratory results from groundwater samples collected from newly installed piezometers were used to determine the spatial variability of the groundwater chemistry within the BRW Site. Low-flow sampling parameters were used to estimate the hydraulic conductivity of the screened aquifer interval. Monthly groundwater levels and transducer data were used to evaluate groundwater elevations, potentiometric surfaces, and seasonal groundwater change. Lithology logs from the piezometer construction and groundwater elevations were used to determine the aquifer geometry.	Laboratory results from groundwater samples collected from newly installed hydrocarbon monitoring wells and existing monitoring wells were used to augment and refine the spatial variability of the groundwater chemistry within the BRW Site. Low-flow sampling parameters were used to estimate the hydraulic conductivity of the screened aquifer interval. Lithology logs from the piezometer construction and manual water level measurements were used to determine the aquifer geometry as well as refine and augment the groundwater elevations, potentiometric surfaces, and seasonal groundwater change.	Two pumping test(s) were conducted to determine the transmissivity, hydraulic conductivity, stativity, presence of hydraulic barriers and/or sources of storage, preferential flow, anisotropy, and heterogeneity of the aquifer, role of confining and/or less conductive units, well efficiency, specific yield, and other relevant information specific to the remedial design.	Groundwater elevations and groundwater samples were collected from select piezometers and monitoring wells during high (Phase III QAPP) and low (Phase II RFC 01 and 02) groundwater and surface water conditions to help refine and augment the spatial variability of the groundwater chemistry within the BRW Site. Low-flow sampling parameters will be used to estimate the hydraulic conductivity of the screened aquifer interval. Monthly groundwater levels were recorded and used to evaluate groundwater elevations, potentiometric surfaces, and seasonal groundwater change.	NA
	Groundwater Elevations, Potentiometric Surface, and Direction of Flow	✓	+	+	+	+			Additional groundwater sampling was conducted before and after the pumping test and samples were submitted for laboratory analyses. These samples were used to refine and augment the spatial variability of the groundwater chemistry within the BRW Site. Manual groundwater level measurements collected during sampling were used to augment and refine the groundwater elevations, potentiometric surface, and direction of flow.	A network of surface water and groundwater monitoring points will be used to determine the impact of BRW groundwater on subsections of SBC during high and low groundwater and surface water conditions. This work included monitoring stream gages, sampling for COCs, and Radon-222 tracing tests to monitor groundwater flux, surface water flux, and COC loading.	
	Seasonal Groundwater Elevation Change	✓	+	+	+	+					
	Evaluation of Groundwater Impact to SBC				0	✓			A network of surface water and groundwater monitoring points were used to determine the impact of BRW groundwater on subsections of SBC as well as assess the potential impacts of the dewatering activities on nearby sites. This work included the installation of additional staff gages in SBC, stream gaging, and sampling for COC and Radon-222 to monitor the groundwater and surface water flux and COC loading.		
	Aquifer Geometry	0		0	✓	+					
Organic Pollutants	Chemistry and Spatial Variability of organic pollutants	0	0	0	✓	+	Laboratory analyses and PID screening of soil samples from test pits and boreholes and groundwater samples from select piezometers were used to determine the chemistry and spatial variability of hydrocarbons.	Groundwater sampling and laboratory analyses of the hydrocarbon monitoring wells and select existing monitoring wells were conducted to refine the chemistry and spatial variability of organic pollutants and help define appropriate Site-specific action levels and determine the proper management plan for soils and groundwater impacted with organic pollutants within the BRW Site. Soil from the newly installed piezometers were screened with PIDs for the presence of hydrocarbons with select samples sent for laboratory analyses. Groundwater samples were taken and submitted for laboratory analysis.	Data was collected to refine the chemistry and spatial variability of organic pollutants and help define appropriate Site-specific action levels and determine the proper management plan for soils and groundwater impacted with organic pollutants within the BRW Site. Soil from the newly installed piezometers were screened with PIDs for the presence of hydrocarbons with select samples sent for laboratory analyses.	Data was collected and sent for laboratory analysis from select wells/piezometers for soil and groundwater to refine the chemistry and spatial variability of organic pollutants and help define appropriate Site-specific action levels and determine the proper management plan for soils and groundwater impacted with organic pollutants within the BRW Site. Soil from the newly installed piezometers was screened with PIDs for the presence of hydrocarbons with select samples sent for laboratory analyses.	Additional organic pollutant data collection will provide more data for the chemistry and spatial variability within BRW Site.
	Plan to Manage Impacted Soil and/or Groundwater	0	0	0	0	0	✓	Additional groundwater sampling and laboratory analyses at those piezometers and monitoring wells that previously contained organic pollutants were collected to refine the chemistry and spatial variability of organic pollutants.			Soil samples and analyses for COCs, nutrients, hydrocarbon concentrations/leachability, and microbial quantification will help to determine impacts to both the existing microbial community and inhibited biological processes that naturally occur in soil. Data will also assist with determining if chemical oxidation is a practical treatment method.
Silver Bow Creek (SBC) Realignment	SBC Bottom Invert at Upstream and Downstream Tie-in Locations	✓				+	The survey team determined the bottom invert at the upstream and downstream tie-in locations on SBC.	NA	NA	NA	Complete a bathymetric survey of the anticipated tie in locations for the reconstructed SBC.
	Evaluation of Potential Lining of Relocated SBC	0	0	0	0	✓	Soil and groundwater chemistry information will be used to determine if a liner will be needed based on the excavation design and the potential impact to the relocated SBC. The additional groundwater data will be used to refine the decision to line the SBC channel.	The additional groundwater data will be used to refine the decision to line the SBC channel.	The additional soil and groundwater chemistry data and the results of the pumping test will be used to determine the excavation design and will guide the decision of whether to line the SBC channel.	The additional groundwater data will be used to refine the decision to line the SBC channel.	The sediment samples will be taken near the tie in locations and submitted for particle sizing analysis to help instruct the design of the SBC channel.

Objective not covered during indicated investigation phase.
 ✓ Objective met during indicated investigation phase.
 0 Objective partially met during indicated investigation phase.
 + Additional data gathered during indicated investigation phase to refine a completed objective.

Acronym Table		
BRW - Butte Reduction Works	ICP - Inductively Coupled Plasma	PID - Photoionization Detector
COC - Contaminant of Concern	MASW - Multichannel Analysis of Surface Waves	QAPP - Quality Assurance Project Plan
GW - Groundwater	NA - Not applicable	SBC - Silver Bow Creek

Table 2. Applicable and Relevant Standard Operating Procedures

SOP Number	Title	Version
PIONEER TECHNICAL SERVICES, INC. STANDARD OPERATING PROCEDURES		
SOP-DE-01	PERSONAL DECONTAMINATION PROCEDURES	12/03/2014
SOP-DE-02	EQUIPMENT DECONTAMINATION	09/08/2020
SOP-DE-02A	EQUIPMENT DECONTAMINATION – PUMPS FOR WELL SAMPLING	05/22/2015
SOP-DE-03	INVESTIGATION DERIVED WASTE HANDLING	12/02/2014
SOP-GW-02	SAMPLING WITH A BAILER	12/03/2014
SOP-GW-02A	SAMPLING WITH A BAILER FOR ORGANIC COMPOUNDS	12/03/2014
SOP-GW-03	DEPTH TO WATER LEVEL MEASUREMENTS	12/03/2014
SOP-GW-10C	PURGING AND SAMPLING WITH A PERISTALTIC PUMP	12/11/2014
SOP-GW-11	GROUNDWATER MONITORING WELL DESIGN AND CONSTRUCTION	04/23/2018
SOP-GW-12	WELL DEVELOPMENT USING A MODIFIED OVER-PUMPING TECHNIQUE	04/10/2018
SOP-GW-14	FIELD WATER QUALITY MEASUREMENTS USING THE GEOTECH MULTI-PROBE FLOWBLOCK FLOW THROUGH DEVICE	05/22/2015
SOP-GW-15	CONTINUOUS GROUNDWATER LEVEL MONITORING (SOLINST MODELS)	06/05/2015
SOP-S-02	SUBSURFACE SOIL SAMPLING	12/11/2014
SOP-S-03	SEDIMENT SAMPLING FROM STREAMS, PONDS, AND LAKES	12/11/2014
SOP-S-12	SAMPLING SOILS FROM A GEOPROBE® LINER	09/25/2020
SOP-S-13	SAMPLING SOILS FROM A CORE GENERATED BY A SONIC DRILL	05/31/2018
SOP-SA-01	SOIL AND WATER SAMPLE PACKAGING AND SHIPPING	12/11/2014
SOP-SA-02	SAMPLE PRESERVATION AND CONTAINERIZATION FOR AQUEOUS SAMPLES	05/28/2015
SOP-SA-03A	FIELD QUALITY CONTROL SAMPLES FOR WATER SAMPLING	09/29/2020
SOP-SA-03B	PREPARATION OF EQUIPMENT RINSATE BLANKS FOR SUBMERSIBLE PUMPS	05/28/2015
SOP-SA-04	CHAIN OF CUSTODY FORMS FOR ENVIRONMENTAL SAMPLES	11/12/2020
SOP-SA-05	PROJECT DOCUMENTATION	12/17/2014
SOP-SFM-02	OPERATING XL3 X-RAY FLUORESCENCE ANALYZER	06/05/2015
SOP-SURVEY-01	STAKING AND SURVEYING	10/24/2016
SOP-SW-01	SURFACE WATER/STREAM SAMPLING	12/17/2014
SOP-SW-02	FIELD SAMPLE FILTRATION	05/28/2015
SOP-WFM-01	FIELD MEASUREMENT OF pH IN WATER	09/29/2020
SOP-WFM-02	FIELD MEASUREMENT OF OXIDATION REDUCTION POTENTIAL IN WATER	12/17/2014
SOP-WFM-03	FIELD MEASUREMENT OF SPECIFIC CONDUCTANCE	12/17/2014
SOP-WFM-04	FIELD MEASUREMENT OF WATER TEMPERATURE	9/30/2020
SOP-WFM-05	STREAMFLOW MEASUREMENT WITH MARSH MCBIRNEY OR FLOWTRACKER2® FLOW METER	04/04/2018
SOP-WFM-07	FIELD MEASUREMENT OF DISSOLVED OXYGEN	12/17/2014
SOP-WFM-08	FIELD TURBIDITY MEASUREMENT	10/13/2020
SOP-WFM-09	BUCKET AND STOPWATCH METHOD FOR MEASURING FLOW	10/13/2020
PIONEER TECHNICAL SERVICES, INC. STANDARD OPERATING PROCEDURES (GEOPROBE)		
SOP-GEOPROBE-01	MOBILIZATION AND LOADING/UNLOADING THE GEOPROBE	11/16/2020
SOP-GEOPROBE-02	PRE AND POST JOB INSPECTION	11/16/2020
SOP-GEOPROBE-03	STARTING AND STOPPING THE KUBOTA ENGINE	11/16/2020
SOP-GEOPROBE-04	DRIVING AND POSITIONING THE GEOPROBE® MODEL 66DTX	11/16/2020
SOP-GEOPROBE-05	GEOPROBE® DT-22 DUAL TUBE SAMPLING SYSTEM	11/16/2020
SOP-GEOPROBE-06	GEOPROBE® DT-325 DUAL TUBE SAMPLING SYSTEM	11/16/2020
SOP-GEOPROBE-07	OPERATING THE GEOPROBE® DURING PROBING OPERATIONS	11/16/2020
SOP-GEOPROBE-08	GEOPROBE 0.5-IN. X 1.4-IN. OD AND 0.75-IN. X 1.4-IN. OD PREPACKED SCREEN MONITORING WELLS	11/05/2013
SOP-GEOPROBE-09	DH66 AUTOMATIC DROP HAMMER	11/16/2020
SOP-GEOPROBE-10	EQUIPMENT DECONTAMINATION - INORGANIC CONTAMINANTS	11/16/2020
O'KEEFE DRILLING COMPANY STANDARD OPERATING PROCEDURES		
GPD5-18	GEOPROBE DRILLING	05/15/2018
MODERN WATER		
N/A	RaPID Assay® PCP Test Kit A00111	11/2019

Table 3. Data Quality Objectives				
Solid Material Characterization	Geotechnical Investigation	Silver Bow Creek Sediment Sampling	Groundwater Characterization	Silver Bow Creek Loading Analysis
HC, WC, and SPLP	GI	SS	HC, PCB, PCP, and GWC	GWC and SWC
<p>This table lists the data quality objectives (DQOs) for the Butte Reduction Works (BRW) Phase III Site Investigation. The investigation is detailed in the BRW Phase III Quality Assurance Project Plan (QAPP). The tables, figures, and sections referenced in this table are part of the BRW Phase III QAPP. The Phase III Site Investigation has been broken into these four components to illustrate how the investigation activities will meet the data gaps listed in Table 1. Each DQO is classified as an "Estimation Problem."</p>				
<p>Step 1: State the Problem: <i>The purpose of this step is to describe the problem to be studied so that the focus of the investigation will not be ambiguous.</i></p>				
<p>Problem: The remedial action (RA) requires the removal of waste (defined by the Waste Identification Screening Criteria [EPA, 2020]) within a removal corridor that will contain a new channel for Silver Bow Creek. The removal corridor is set within the BRW Site (Site) and the extents are generally defined in the BPSOU Consent Decree (CD) (EPA, 2020). The exact extents of the removal corridor and the depth of waste removal are to be determined during the remedial design (RD).</p> <p>Soil impacted with organic pollutants (petroleum-based, polychlorinated biphenyls [PCB], pentachlorophenol [PCP], and dioxins) encountered during waste removal within the removal corridor will be properly managed/disposed. Soil impacted with organic pollutants that is outside of the removal corridor and with concentrations above Site-specific action levels will be properly managed. To define appropriate Site-specific action levels and determine the proper management plan for soil impacted with organic pollutants both within and outside the removal corridor, additional information is needed to refine the extents of the impacted soil and the concentrations of organic pollutants within the soil.</p> <p>Additionally, the RA requires that contaminant of concern (COC)-impacted groundwater within the Site be hydraulically controlled to limit the extent of COC-impacted groundwater discharged to surface water and sediments. To adequately design the BRW hydraulic control, additional information is needed on the chemical stability/leachability of solid materials that may remain within the removal corridor after the RA is complete. In a related effort, materials that are located outside of the removal corridor may be characterized to assist with the design and optimization of the BRW hydraulic control.</p>	<p>Problem: The RA, including end land use, calls for geotechnical details of the Site to evaluate stability conditions during RA construction activities to ensure adequate soil stability around existing structures as well as in areas of potential structural features. Past investigations have collected data related to the soil lithologies within the Site; however, a geotechnical investigation focused on evaluating the physical properties of the soil has not been completed. This information is needed to properly design the excavation surface, particularly the slopes, and any structural features such as foundations, parking lots, etc. that may be part of the end land use design for the Site.</p>	<p>Problem: The RA requires relocation of Silver Bow Creek and the 100-year floodplain away from existing slag walls and associated contaminated sediments and in a new alignment through the Site within the waste removal corridor. A relocated stream system that does not provide the appropriate amount of energy to transport and deposit sediment relative to the stabilized existing stream may result in the encroachment of the stream and 100-year floodplain location into adjacent contaminants outside of the removal corridor. Additionally, if the relocated stream system does not provide the appropriate amount of energy to transport and deposit sediment equal to the existing stream system, the realigned Silver Bow Creek and upgradient and downgradient sections may respond to the change in system energy and encroach out of the removal corridor and existing 100-yr floodplain unpredictably. The existing Silver Bow Creek stream is considered stable and data representing the stream sediment particle size distribution is required to guide the design of the realigned Silver Bow Creek.</p>	<p>Problem: The Site has been characterized to a large degree by previous investigations; however, the data collected in past investigations do not sufficiently characterize the representative range of seasonal groundwater chemistry (such as during high- and low-groundwater and surface water conditions) or provide a potential early detection network to ensure that notable concentrations of PCP from the Montana Pole and Treating Plant (MPTP) Site (located to the west of the BRW Site) do not migrate during construction dewatering and/or as a result of implementing the BRW hydraulic control. A shift in groundwater elevations, implementing the BRW hydraulic control and/or construction dewatering, may result in a corresponding shift in the nature and extent of PCP- or COC-impacted or hydrocarbon-bearing groundwater within and/or adjacent to the Site. Information regarding the nature and extent of this potential change is required to guide the design of the BRW hydraulic control, construction dewatering, the realigned Silver Bow Creek, and/or other groundwater-related design aspects.</p>	<p>Problem: RA requires that COC-impacted groundwater within the Site be hydraulically controlled to limit the extent of impacted groundwater discharge to surface water and sediments in BPSOU generally and in the Site specifically. To adequately design the BRW hydraulic control, additional information is needed to evaluate the changes in the nature, extent, and source of the COC loading to Silver Bow Creek from the area between SS-05B and SS-06A during a representative range of seasonal groundwater and surface water conditions (such as low- and high-groundwater conditions).</p> <p>The Silver Bow Creek Loading Analysis will also function as a pre-remediation condition for later comparison to the post-remediation condition. Comparison of the two conditions will measure the remedial design efficacy and may also inform changes to the hydraulic control design.</p>
<p>Available Resources and Schedule: Pioneer Technical Services Inc. (Pioneer) is the contractor responsible for conducting the elements of the Phase III Site Investigation under the direction of Atlantic Richfield Company. All personnel completing field work will be properly trained in how to perform their tasks. The laboratory(s) selected to analyze the soil and groundwater samples will be an Atlantic Richfield-approved laboratory(s). The Phase III Site Investigation work must be completed by December 2022 to meet the current required design schedule for the RA. However, potential constraints could delay field work and/or the RD (Step 5) and will need to be addressed by Atlantic Richfield and Agencies if they occur.</p> <p>Conceptual Model of Environmental Problem: The Site has a history of multiple industrial uses. As a result, there are accumulations of slag, tailings, demolition debris, and other impacted materials that may be a source of COCs and additional constituents of concern (e.g., manganese, trace elements, organic pollutants, etc.) to the underlying groundwater. The Phase III QAPP includes a detailed description on the Site history, previous investigations, and required RA (Section 2.0).</p> <p>Planning Team: The Phase III QAPP includes a detailed description on the project organization and responsibilities (Section 7.0).</p>				
<p>Step 2: Identify the Goals of the Study: <i>This step identifies the principal questions that the study will attempt to resolve and what actions may result.</i></p>				
<p>Principal Study Questions:</p> <ul style="list-style-type: none"> • What are the locations, depths, and total volume of waste materials (as defined by the Waste Identification Screening Criteria [EPA, 2020]) within the Site? • What are the concentrations and characteristics of soils impacted by organic pollutants within the Site? And what are the locations, depths, and total volume of soils impacted with organic pollutants within the Site? Based on previous sampling, the primary organic pollutant of concern for soil within the Site is petroleum compounds or hydrocarbons. • What is the chemical stability/leachability of select solid materials that may remain within the removal corridor after the RA is complete? • What is the chemical leachability of select solid materials adjacent to the Site that may need to be considered during the design and 	<p>Principal Study Questions:</p> <ul style="list-style-type: none"> • What are the geotechnical properties of the subsurface material that will be encountered during the RA and/or will remain in place after RA? • How will the physical characteristics (shear strength, bearing capacity, chemistry, etc.) of the soil remaining after removal impact the design of the excavation surface and potential end land use infrastructure such as parking lots, walking trails, structural foundations, etc.? <p>Estimation Statement: A geotechnical investigation will address the principal</p>	<p>Principal Study Questions:</p> <ul style="list-style-type: none"> • What is the particle size distribution of the deposited sediment in the existing Silver Bow Creek? • How will the particle size distribution of the sampled sediment impact the design of the realigned stream and the 100-yr floodplain? <p>Estimation Statement: Sediment sample particle size distribution analysis will provide the particle size distribution of the sediment deposited in the existing stream and 100-yr floodplain. Sediment transport capacity calculations guided by the sediment particle size distribution will inform the stability and function of the realigned stream and 100-yr floodplain to achieve proper stabilization and minimize the total</p>	<p>Principal Study Questions:</p> <ul style="list-style-type: none"> • What is the nature and extents of COC-impacted groundwater within the Site? • How do seasonal changes in groundwater and surface water conditions, such as the difference between low- and high-groundwater and surface water conditions, affect the chemical variability and spatial extents of COC-impacted or hydrocarbon-bearing groundwater within and adjacent to the Site? • What are the baseline conditions between the Site and the MPTP Site and how will the BRW hydraulic control and/or RA construction dewatering affect the hydraulic 	<p>Principal Study Question:</p> <ul style="list-style-type: none"> • Does the amount or type of COC loading to Silver Bow Creek from station SS-05B to SS-06A change as a result of seasonal groundwater elevation fluctuations within the Site? <p>Estimation Statement: The principal study questions will be answered by measuring surface water stages, collecting groundwater samples, and stream flow measurements from select locations for specified analyses. The surface water stage measurements, flow measurements, and sampling will occur on the same day. The data will be used to estimate the changes in chemical concentration and</p>

Table 3. Data Quality Objectives				
Solid Material Characterization	Geotechnical Investigation	Silver Bow Creek Sediment Sampling	Groundwater Characterization	Silver Bow Creek Loading Analysis
<p>optimization of the BRW hydraulic control with regards to protection of human health and the environment?</p> <p><u>Estimation Statement:</u> The principal study questions will be answered by documenting the lithology of and collecting samples from the Waste Characterization Boreholes as well as collecting samples from soil cores that were archived from the Site during the Phase I Site Investigation activities. The lithological logs and sample results from the Waste Characterization Boreholes and archived soil cores will be used to refine the estimated locations, depths, and total volume of waste materials and materials impacted with organic pollutants within the Site and to identify materials with notable quantities of leachable COCs that may remain within the removal corridor after the RA is complete. These data will be used during the RD to define the horizontal and vertical extents of the waste removal, to evaluate appropriate management methods for materials impacted with organic pollutants, and to adequately design and optimize the BRW hydraulic control. The lithology logs and sample results from the Phase III Piezometer Boreholes will be used to identify materials with notable quantities of leachable COCs that may exist adjacent to the Site and will be accounted for to optimize the design of the BRW hydraulic control.</p> <p>The data validation procedures detailed in Step 6 will ensure the data collected is useable for this intended purpose. Additional detail on the confidence level and acceptable error of the analysis method chosen to estimate the bottom of waste excavation surface is provided in the BRW Pre-Design Investigation Evaluation Report (PDI ER) (Atlantic Richfield Company, 2020).</p>	<p>study questions. Analysis of lithological logs and sample results will inform quantitative and qualitative estimates for design elements and material needed to achieve proper end land use stability.</p>	<p>new input into upgradient and down gradient stream sections.</p>	<p>gradient and concentrations of PCP-impacted groundwater located to the west of the Site?</p> <p><u>Estimation Statement:</u> The principal study questions will be answered by measuring water elevations, collecting field parameters, installing piezometers, and collecting groundwater samples for specified analyses from select piezometers and monitoring wells. The water elevations, field parameters, groundwater analytical results, and other appropriate data will be used to estimate the spatial variability of groundwater chemistry within the Site during different seasonal conditions and identify any pre-existing concentrations of PCP to the west of the Site. Additional piezometer locations will help define an “early detection network” to ensure that notable concentrations of PCP do not migrate during construction dewatering or when the BRW hydraulic control is brought online. These data will be used to complete the characterization of groundwater within and to the west of the Site and inform the groundwater-related aspects of the design.</p>	<p>load to Silver Bow Creek from a representative range of seasonal groundwater and surface water conditions (such as the changes between low- and high-groundwater and surface water conditions).</p>

Table 3. Data Quality Objectives				
Solid Material Characterization	Geotechnical Investigation	Silver Bow Creek Sediment Sampling	Groundwater Characterization	Silver Bow Creek Loading Analysis
Step 3: Identify Information Inputs: <i>The purpose of this step is to identify the informational variables that will be required to answer the principal study questions and determine which variables require environmental measurements.</i>				
<p><u>Types of Information that are Needed:</u></p> <ul style="list-style-type: none"> Survey-grade Global Positioning System (GPS) location coordinates collected for additional borehole locations. Classification and lithology recorded for each borehole. Presence of hydrocarbons (via sight, smell, and/or detection with two photoionization detectors [PIDs]) recorded for each borehole. If the presence of hydrocarbons is detected, a sample may be collected for hydrocarbon analyses (Table 6 and Table 7). In boreholes where hydrocarbons have been detected, a soil sample may be collected near the top of the saturated layer (in the capillary fringe) for hydrocarbon analyses (Table 6 and Table 7), as determined by the Field Team Leader and Contractor Project Manager (CPM), in consultation with the Contractor Quality Assurance Officer (QAO). X-ray fluorescence (XRF) analysis will be conducted within the borehole cores of the Waste Characterization Boreholes to identify the general bottom of waste horizon. This horizon will be confirmed with ICP-MS samples for specified analytes if there is enough soil to fulfill the required sample volume (Step 5) (Table 6). If the bottom of waste horizon does not have sufficient sample volume to collect an ICP-MS sample, an official XRF analysis will be conducted and the upper 95% correlation of XRF to ICP-OES data from the BRW PDI ER will be used to correlate the data. XRF analyses will be conducted on each lithologic layer from the Waste Characterization Boreholes and Phase III Piezometers. The results will be used to identify appropriate locations to collect Synthetic Precipitation Leaching Procedure (SPLP) samples. (Step 5) (Table 6). SPLP analyses results from archived soil cores. <p><u>Source of Additional Information:</u></p> <ul style="list-style-type: none"> Phase I Site Investigation (BRW Phase I QAPP and Request for Change [RFC] documents) (Atlantic Richfield Company 2021a). Phase II Site Investigation (BRW Phase II QAPP) (Atlantic Richfield Company 2021b). BRW PDI ER. BRW Smelter Site Draft Test Pit Report (NRDP, 2016). <p><u>Applicable Limits/Thresholds:</u></p> <ul style="list-style-type: none"> Waste Identification Screening Criteria (EPA, 2020). Montana Risk-Based Screening Levels (DEQ, 2018). <p><u>Appropriate Sampling and Analysis Methods:</u></p> <ul style="list-style-type: none"> Sampling and analysis methods are detailed in Table 6. All laboratory results will go through a Level 2A validation. The required quantification limit is listed in Table 6. <p><u>Factors That will Contribute to Waste Excavation Depth:</u></p> <ul style="list-style-type: none"> Final corridor width at certain locations. Construction limitations on the removal of waste near boundaries. Feasibility of dewatering near other impacted areas. Capture extents of proposed BRW hydraulic control. Other factors determined during the design. 	<p><u>Types of Information that are Needed:</u></p> <ul style="list-style-type: none"> Classification and lithology recorded for each borehole. Field geotechnical evaluation of soils from selected boreholes, and physical laboratory results for moisture content, resistivity, pH, sulfate, particle size distribution, Atterberg Limits, Standard Proctor, California Bearing Ratio, Triaxial and consolidation analysis for samples at the discretion of the geotechnical engineer and as listed in Table 6. Standard Penetration Tests. Shelby Tube samples. Survey-grade GPS location coordinates for additional boreholes. <p><u>Source of Additional Information:</u></p> <ul style="list-style-type: none"> Phase I Site Investigation (BRW Phase I QAPP). Phase II Site Investigation (BRW Phase II QAPP). BRW PDI ER. Parallel Solid Material Characterization effort. Results from any other investigation activities where borehole and test pit data were collected from the Site and surrounding area (if data meet applicable performance or acceptance criteria). <p><u>Applicable Limits/Thresholds:</u></p> <ul style="list-style-type: none"> This is a preliminary investigation to gather information. Limits/thresholds will depend on finalized end land use plans and the design of the removal corridor. <p><u>Appropriate Sampling and Analysis Methods:</u></p> <ul style="list-style-type: none"> Sampling and analysis methods are detailed in Table 6. 	<p><u>Types of Information that are Needed:</u></p> <ul style="list-style-type: none"> Physical laboratory results for particle size distribution as detailed in Table 6. <p><u>Source of Additional Information:</u></p> <ul style="list-style-type: none"> Results from any other Silver Bow Creek sediment sampling and particle size distribution analysis that may have been performed. <p><u>Applicable Limits/Thresholds:</u></p> <ul style="list-style-type: none"> This is a preliminary investigation to gather information. Limits/thresholds will depend on finalized end land use plans and the design of the realigned stream and 100-yr floodplain. <p><u>Appropriate Sampling and Analysis Methods:</u></p> <ul style="list-style-type: none"> Sampling and analysis method is detailed in Table 6. 	<p><u>Types of Information that are Needed:</u></p> <ul style="list-style-type: none"> Survey-grade GPS location coordinates and measuring point for each piezometer, staff gage, and sampling location listed in Table 7. Groundwater elevations measured from the locations listed in Table 7. Groundwater samples analyzed for the analytes as outlined in Table 6 and Table 7. A Groundwater Conceptual Site Model that will simulate the extent of drawdown and consider the impact to MPTP Site. Supplemental data to be collected during the 2021 BPSOU Butte Treatment Lagoons Stress Test. Other design-related data, as deemed necessary by the Field Team Leader and/or CPM in consultation with the Contractor QAO. <p><u>Source of Additional Information:</u></p> <ul style="list-style-type: none"> Phase I Site Investigation (BRW Phase I QAPP). Phase II Site Investigation (BRW Phase II QAPP including RFC-BRW-2021-01). BRW PDI ER. Parallel Solid Material Characterization effort. 2021 BPSOU Butte Treatment Lagoons Stress Test. Results from any other investigation activities where groundwater and surface water data were collected from the Site and surrounding area (if data meet applicable performance or acceptance criteria). <p><u>Applicable Limits/Thresholds:</u></p> <ul style="list-style-type: none"> Normal Flow Compliance Standards listed in Table 2-1 of Appendix D to the BPSOU CD (EPA, 2020). DEQ Circular DEQ-7 Standards (DEQ, 2019). Montana Risk-Based Screening Levels (DEQ, 2018). <p><u>Appropriate Sampling and Analysis Methods:</u></p> <ul style="list-style-type: none"> Sampling and analysis methods are detailed in Table 6. All laboratory results will go through a Level 2A validation. The required quantification limit is listed in Table 6. 	<p><u>Types of Information that are Needed:</u></p> <ul style="list-style-type: none"> Survey-grade GPS location coordinates and measuring point elevations collected at each of the groundwater and surface water measurement and/or sampling locations identified in Table 7. Surface water and groundwater samples analyzed for the analytes as outlined in Table 6 and Table 7. The samples will be collected during a range of seasonal groundwater and surface water conditions, such as low- and high-groundwater and surface water conditions. Stage and elevation measurements from existing and installed staff gages. Stream flow measurements collected from existing staff gages. <p><u>Source of Additional Information:</u></p> <ul style="list-style-type: none"> Phase I Site Investigation (BRW Phase I QAPP). Phase II Site Investigation (BRW Phase II QAPP). BRW PDI ER. Results from any other investigation activities where groundwater and surface water data were collected from the Site and surrounding area (if data meet applicable performance or acceptance criteria). <p><u>Applicable Limits/Thresholds:</u></p> <ul style="list-style-type: none"> Normal Flow Compliance Standards listed in Table 2-1 of Appendix D to the BPSOU CD (EPA, 2020). <p><u>Appropriate Sampling and Analysis Methods:</u></p> <ul style="list-style-type: none"> Sampling and analysis methods are detailed in Table 6. All laboratory results will go through a Level 2A validation. The required quantification limit is listed in Table 6.

Table 3. Data Quality Objectives				
Solid Material Characterization	Geotechnical Investigation	Silver Bow Creek Sediment Sampling	Groundwater Characterization	Silver Bow Creek Loading Analysis
Step 4: Define the Boundaries of the Study: <i>The purpose of this step is to define the spatial and temporal boundaries of the study.</i>				
<p><u>Target Population:</u> Additional boreholes to be installed are listed in Table 7 and shown on Figure 4. Samples to be collected from the archived soil cores are listed in Figure 6.</p> <p><u>Specific Spatial Boundaries, Temporal Boundaries, and Other Practical Constraints:</u> The targeted completion depths are listed in Table 7. Actual placement and/or completion of the new boreholes in the field will be subject to change based on field conditions, including existing infrastructure and land use in the area due to ongoing Butte-Silver Bow operations, or as deemed necessary by Field Team Leader and/or CPM in consultation with the Contractor QAO.</p> <p>The holding time for the soil samples from the archived core has been exceeded; however, Atlantic Richfield believes this will have little effect on the quality of the data for the COCs (arsenic, cadmium, copper, lead, and zinc).</p> <p><u>Scale of Estimates to be Made:</u> The lithological log and sample results for the Waste Characterization Boreholes and archived soil cores will be used, in combination with other boring logs and sample results, to identify impacted and unimpacted material, the location and concentrations of organic pollutants, and the location (lithologies) of materials with leachable quantities of COCs that may remain within the removal corridor after the RA is complete. To optimize the design of the BRW hydraulic control, the lithological log and sample results for each boring located outside the removal corridor (the Phase III Piezometers) will be used, in combination with other boring logs and sample results, to identify materials with leachable quantities of COCs.</p>	<p><u>Target Population:</u> Figure 4 and Table 7 shows the areas to be analyzed during the Geotechnical Investigation.</p> <p><u>Specific Spatial Boundaries, Temporal Boundaries, and Other Practical Constraints:</u> Personnel will coordinate with ongoing Butte-Silver Bow operations during drilling. Actual placement and/or completion of the borehole locations in the field will be subject to change based on field conditions (including existing infrastructure and land use in the area due to ongoing Butte-Silver Bow operations), changes to the design (including the removal corridor, excavation surface, and end land use features), approval from adjacent landowners, or as deemed necessary by Field Team Leader and/or CPM in consultation with the Contractor QAO. Figure 4 delineates the conceptual area for end land use structures.</p> <p><u>Scale of Estimates to be Made:</u> Geotechnical evaluation from soil data will inform the design of end land use plans and inform the design of the excavation surface within the removal corridor.</p>	<p><u>Target Population:</u> Figure 4 shows the areas to be sampled during the sediment sampling.</p> <p><u>Specific Spatial Boundaries, Temporal Boundaries, and Other Practical Constraints:</u> Actual sample locations in the field will be subject to change based on field conditions, changes to the stream tie in location, or as deemed necessary by Field Team Leader and/or CPM in consultation with the Contractor QAO. Figure 4 delineates the conceptual stream tie in locations.</p> <p><u>Scale of Estimates to be Made:</u> Sediment transport capacity calculations based on particle size distribution analysis from sediment sample data will inform the design of the stream system and 100-yr floodplain within the removal corridor.</p>	<p><u>Target Population:</u> Figure 7 and Table 7 show which locations will be sampled.</p> <p><u>Specific Spatial Boundaries, Temporal Boundaries, and Other Practical Constraints:</u> Collection of physical and chemical data will need to occur during a representative range of groundwater and surface water conditions, such as high- and low-groundwater and surface water conditions, and also at relevant locations adjacent to the Site. Actual placement and/or completion of the borehole and piezometer locations in the field, the locations selected for sampling, and type of analysis will be subject to change as deemed necessary by the Field Team Leader and/or CPM in consultation with the Contractor QAO.</p> <p><u>Scale of Estimates to be Made:</u> The water elevations and groundwater analytical results will be used, in combination with other groundwater analytical results previously collected, to characterize changes in the extent of impacted groundwater within the Site during high- and low-groundwater conditions. These data will be collected for purposes of designing and optimizing the BRW hydraulic control and protecting human health and the environment.</p> <p>Water quality data collected from the new piezometers will also be used to provide a chemistry baseline to the west of the Site and will be used as an early detection network for migration of PCP.</p>	<p><u>Target Population:</u> Figure 8 and Table 7 indicate which locations will be sampled and compared for loading analysis.</p> <p><u>Specific Spatial Boundaries, Temporal Boundaries, and Other Practical Constraints:</u> Collection of physical and chemical data will need to occur during a representative range of seasonal groundwater and surface water conditions. Actual placement and/or completion of the staff gage locations in the field, the locations selected for sampling and type of analysis will be subject to change as deemed necessary by the Field Team Leader and/or CPM in consultation with the Contractor QAO.</p> <p><u>Scale of Estimates to be Made:</u> Because data will be collected on several reaches of Silver Bow Creek, the flow measurements and sampling results for each reach and sampling event will be compared to one another and used to estimate the changes in chemical concentration and load to Silver Bow Creek on a per-reach basis.</p>
<p><u>General Spatial Boundaries, Temporal Boundaries, and Other Practical Constraints:</u> Fieldwork will begin once Agency approval has been received. A proposed schedule is shown in Table 4. Work will be performed as weather conditions permit. Coordination with Butte-Silver Bow will be required for each project task taking place in the vicinity of their operations, particularly near the crushing plant and asphalt plant. Potential constraints that could delay fieldwork include adverse weather conditions, contractor availability, coordination with land managers/users, challenges with drilling caused by Site conditions, unforeseen challenges with Covid-19 pandemic, or other unforeseen issues. Major project delays resulting from these constraints will be recorded in the field logbooks and reported to the Agencies.</p>				
Step 5: Develop the Analytical Approach: <i>The purpose of this step is to specify the appropriate population parameters for making estimates.</i>				
<p><u>Population Parameters:</u></p> <ul style="list-style-type: none"> • Bottom of waste elevation for each Waste Characterization Borehole. • Location (lithologies) of materials with leachable quantities of COCs within the Waste Characterization Boreholes and Phase III Piezometer Boreholes. • Location, depth, volume, and concentrations of materials impacted by organic pollutants within the Waste Characterization Boreholes and Phase III Piezometer Boreholes. <p><u>Specification of Estimator:</u></p> <ul style="list-style-type: none"> • The bottom of waste elevation for the Waste Characterization Borehole locations will be used to refine the estimated location and volume of waste materials within the Site. • The analysis of the data points to refine the bottom of waste horizon will be completed using the Leapfrog Works software (or equivalent). This effort will be completed as part of the RD. 	<p><u>Population Parameters:</u></p> <ul style="list-style-type: none"> • Description of soil properties, characteristics, and presence of slag and demolition debris. • Soil shear strength, unit weight, consolidation, and results of the California Bearing Ratio test. • Groundwater table location and pore water pressure. • Soil bearing capacity, lateral earth loads, and soil corrosivity. • Seismic Zone. • General geotechnical modeling and calculations. • Slope stability analysis. • Liquefaction analysis. 	<p><u>Population Parameters:</u></p> <ul style="list-style-type: none"> • Sediment particle size distribution. • Stream sediment transport capacity calculations. <p><u>Specification of the Estimator:</u> A particle size distribution analysis will yield qualitative results needed to inform the stream realignment design and 100-yr floodplain within the removal corridor.</p>	<p><u>Population Parameters:</u></p> <ul style="list-style-type: none"> • Chemical and spatial variability and baseline • Groundwater elevation (seasonal change) <p><u>Specification of Estimator:</u> Temporal changes to groundwater chemistry and elevation will be used to improve the characterization of groundwater within the Site and identify how it influences COC- or hydrocarbon-impacted groundwater within the Site. The results of this analysis will be used in the basis of design report to determine the extent of the BRW hydraulic control that is anticipated to meet the appropriate base flow standards in Silver Bow Creek.</p> <p>Chemical and spatial variability and groundwater elevations to the west of the Site will be used to establish a baseline for</p>	<p><u>Population Parameter:</u></p> <ul style="list-style-type: none"> • Chemical and physical characteristics of groundwater discharge into a specific surface water reach during a representative range of seasonal groundwater and surface water conditions. <p><u>Specification of Estimator:</u> The total groundwater discharged into a specific surface water reach will be used with changes in chemical concentrations to identify loading changes within Silver Bow Creek during a representative range of groundwater and surface water conditions, such as high- and low-groundwater and surface water conditions.</p>

Table 3. Data Quality Objectives				
Solid Material Characterization	Geotechnical Investigation	Silver Bow Creek Sediment Sampling	Groundwater Characterization	Silver Bow Creek Loading Analysis
<p>• The location (lithologies) of materials with leachable quantities of COCs will be used to estimate the location and extent of the secondary source that may remain within the removal corridor after the RA is complete and the secondary source from materials outside the removal corridor. This configuration will be used during RD of the BRW hydraulic control.</p> <p><u>Specific Action Levels:</u></p> <ul style="list-style-type: none"> • The bottom of waste elevation for the Waste Characterization Boreholes will be defined by the upper surface of the first lithological layer that passes the Waste Identification Screening Criteria (EPA, 2020) and where all deeper intervals continue to pass these criteria. • The trigger for the collection of SPLP samples (Table 6 and Table 7 show from which location SPLP samples will be taken) from individual soil layers is based on two criteria: <ul style="list-style-type: none"> ○ Is the sample coming from material that will not be removed (i.e., is located below and/or adjacent to the extent of the current excavation surface)? ○ Does the layer have field XRF concentration(s) that suggest notable concentrations of leachable COCs? <p>If the answer to both questions is “yes,” an SPLP sample may be collected, as determined by the CPM and Contractor QAO.</p>	<p><u>Specification of the Estimator:</u> A combination of solid material characterization and geotechnical analysis will yield quantitative and qualitative results needed to inform the design of end land use features and inform the excavation design.</p>		<p>groundwater conditions (hydraulic gradient and chemistry) between the MPTP Site and the BRW Site, inform the design of the BRW hydraulic control and construction dewatering system, and provide an early detection network during construction.</p>	<p>The analysis of the data will be used in the basis of design report to inform the design of the BRW hydraulic control.</p>
<p>Step 6: Specify Performance or Acceptance Criteria: <i>The purpose of this step is to define the performance or acceptance criteria that the collected data will need to achieve.</i></p>				
<p><u>Specify Acceptable Limits on Estimation Uncertainty:</u> The data validation procedures detailed below will ensure the data collected is useable to meet this objective (Step 2). Additional detail on the confidence level and acceptable error of the analysis method chosen to estimate the bottom of waste excavation surface is provided in the PDI ER.</p>	<p><u>Specify Acceptable Limits on Estimation Uncertainty:</u> While some uncertainty in the estimate is inevitable and a minimum level of uncertainty is preferred, traditional statistics do not apply to the qualitative aspects of a Geotechnical Investigation. Therefore, non-statistical (expert judgement) methods will be used primarily as the basis for geotechnical evaluation.</p>	<p><u>Specify Acceptable Limits on Estimation Uncertainty:</u> While some uncertainty in the estimate is inevitable and a minimum level of uncertainty is preferred, traditional statistics do not apply to the qualitative aspects of a sediment sample collection. Therefore, non-statistical (expert judgement) methods will be used primarily as the basis for sediment sampling.</p>	<p><u>Specify Acceptable Limits on Estimation Uncertainty:</u> This task includes additional water quality data collected and does not have any specific acceptable limits on estimation uncertainty except for the general performance or acceptance criteria included below. <u>Data validation</u> data from RFC to the Phase II QAPP field sampling are evaluated under these DQOs.</p>	<p><u>Specify Acceptable Limits on Estimation Uncertainty:</u> A composite error, based on equipment and lab errors, will be determined to identify if the samples collected are statistically different. The composite error will be presented in the revised PDI ER.</p>
<p><u>General Performance or Acceptance Criteria:</u> For estimation problems (Step 6B of EPA guidance), the collected data will be used to estimate unknown parameters, together with some reported measure of uncertainty in the estimate. Errors occur when data mislead the Site managers into choosing an inappropriate response. The potential for errors exists because all field and analytical measurements inherently contain sampling error and/or measurement errors.</p> <ul style="list-style-type: none"> • Sampling Error: Sampling design errors occur when the data collection scheme does not adequately address the inherent variability of the matrix being sampled. Sampling design errors will be minimized by following the procedures outlined in the Phase III QAPP. • Measurement Error: Measurement errors occur from the inherent variability in taking field measurements and/or collecting, preparing, and analyzing an environmental sample. Field measurement errors will be minimized by following the relevant Standard Operating Procedures (SOPs) (e.g., SOP for water level measurements). <p>All analytical data gathered during the Phase III Site Investigation will be validated to ensure that the data are suitable for their intended purpose. Specific data validation processes that will be followed to ensure analytical results are within acceptable limits are detailed in Section 3.1. The data validation process will include evaluating analytical control limits and the precision, accuracy, representativeness, comparability, and completeness parameters. If significant issues with the data are found, results will be discussed with the EPA.</p>				
<p>Step 7: Develop the Plan for Obtaining the Data: <i>This step identifies a resource-effective data collection design for generating data expected to satisfy the DQOs.</i> Summaries of the data collection design are listed here. A more detailed description is listed in the Phase III QAPP.</p>				
<p><u>Sampling Design:</u> Log, screen, and/or sample the soil cores, as listed in Table 6, Table 7, and Figure 4. Details are discussed in Section 4.2.</p> <p><u>Evaluating Key Assumptions:</u> The focus of this objective for the Phase III Site Investigation is to collect additional useable data from the Waste Characterization Boreholes to adequately refine the estimated locations and total volume of waste and impacted materials within the Site and to identify materials with leachable quantities of COCs that may remain within the removal corridor after the RA is complete. The Leapfrog Works software realizes data from the Waste Characterization Boreholes to model waste material and leachable quantities of COCs within the Site. Block models within Leapfrog identify where additional data may be needed to prove assumptions made in the Leapfrog model for waste volumes. Formulas involving the Kriging efficiency, slope of regression, and average distance between data points will determine if collected data are sufficiently extrapolated</p>	<p><u>Sampling Design:</u> Log, screen, and sample the soil cores, as listed in Table 6, and Table 7, and Figure 4. Log the results of the standard penetration test (SPT). Details are discussed in Section 4.3.</p> <p><u>Evaluating Key Assumptions:</u> The focus of this objective for the Phase III Site Investigation is to collect additional useable data for a Geotechnical Investigation. The data validation procedures detailed in Step 6 will ensure the data collected is useable for this intended purpose. If the criteria from Step 6 are not met, if design criteria change, or if more information is needed, additional geotechnical boreholes may be</p>	<p><u>Sampling Design:</u> Collect sediment samples at <u>locations shown on Figure 4. Analyze sediment samples for particle size distribution as detailed in Table 6.</u> Details are discussed in Section 4.5.</p> <p><u>Evaluating Key Assumptions:</u> The focus of this objective for the Phase III Site Investigation is to collect additional useable samples for particle size distribution analysis. The data validation procedures detailed in Step 6 will ensure the data collected is useable for this intended purpose. If the criteria from Step 6 are not met, if design criteria change, or if more information is needed, additional stream sediment samples may be collected. Any additional work will be proposed in an RFC for Agencies’ review and approval.</p>	<p><u>Sampling Design:</u> The four new piezometers, new and existing staff gage locations, and existing sampling locations shown on Figure 7 and listed in Table 7 will be surveyed, measured, sampled, and analyzed for the analytes listed in Table 6. Details are discussed in Section 4.4.</p> <p><u>Evaluating Key Assumptions:</u> Additional sampling will provide enough information to adequately characterize the chemistry within and to the west of the Site and identify whether groundwater-elevation variability alters PCP, COC- and/or hydrocarbon-impacted groundwater within and to the west of the Site (see Step 5 and 6). If the criteria from Step 6</p>	<p><u>Sampling Design:</u> Collect groundwater, surface water samples, and flow measurements from the locations shown on Figure 8 and in Table 7, then analyze for the analytes listed in Table 6. Details are discussed in Section 4.5.</p> <p><u>Evaluating Key Assumptions:</u> Sampling will provide enough information to adequately estimate the COC loading to Silver Bow Creek between SS-05B and SS-06A (see Step 5 and 6) during a representative range of seasonal groundwater and surface water conditions. If the criteria from Step 6 are not met, additional sampling may be conducted if additional information is needed. Any additional work</p>

Table 3. Data Quality Objectives				
Solid Material Characterization	Geotechnical Investigation	Silver Bow Creek Sediment Sampling	Groundwater Characterization	Silver Bow Creek Loading Analysis
<p>between data points or if additional sampling is necessary. This objective also seeks to identify materials in the Phase III Piezometer Boreholes with leachable quantities of COCs that may impact the design of the BRW hydraulic control (see Step 5 and 6).</p> <p>The data validation procedures detailed in Step 6 will ensure the data collected is useable for this intended purpose. If the criteria from Step 6 are not met, the usability of the data will be evaluated with Agencies.</p> <p>Additional detail on the confidence level and acceptable error of the analysis method chosen to estimate the bottom of waste excavation surface is provided in the PDI ER.</p>	<p>installed. Any additional work will be proposed in an RFC for Agencies' review and approval.</p>		<p>are not met, additional samples may be collected, or additional piezometers and/or staff gages may be installed if additional information is needed. Any additional work will be proposed in an RFC for Agencies' review and approval.</p>	<p>will be proposed in an RFC for Agencies' review and approval.</p>

References:

- Atlantic Richfield Company, 2021a. Silver Bow Creek/Butte Area NPL Site Butte Priority Soils Operable Unit Butte Reduction Works (BRW) Phase I Quality Assurance Project Plan (QAPP) (which includes associated Request for Change documents). Revision 3. Prepared by Pioneer Technical Services, Inc. February 2021.
- Atlantic Richfield Company, 2021b. Silver Bow Creek/Butte Area NPL Site Butte Priority Soils Operable Unit Final Revised Butte Reduction Works (BRW) Smelter Area Mine Waste Remediation and Contaminated Groundwater Hydraulic Control Site 2021 Phase II Quality Assurance Project Plan (which includes associated Request for Change documents). Revision 2. Prepared by Pioneer Technical Services Inc. February 2021.
- Atlantic Richfield Company, 2020. Silver Bow Creek/Butte Area NPL Site Butte Priority Soils Operable Unit Draft Final Butte Reduction Works (BRW) Smelter Area Mine Waste Remediation and Contaminated Groundwater Hydraulic Control Site Pre-Design Investigation (PDI) Evaluation Report. Prepared by Pioneer Technical Services Inc. October 6, 2020.
- DEQ, 2019. Circular DEQ-7 Montana Numeric Water Quality Standards. Montana Department of Environmental Quality. June 2019.
- DEQ, 2018. Montana Risk-Based Corrective Action Guidance for Petroleum Releases. Montana Department of Environmental Quality, May 2018.
- EPA, 2020. Consent Decree for the Butte Priority Soils Operable Unit. Partial Remedial Design/Remedial Action and Operation and Maintenance. U.S. Environmental Protection Agency. February 13, 2020. Available at <https://www.co.silverbow.mt.us/2161/ButtePriority-Soils-Operable-Unit-Conse>. Sections referenced in this text include Table 1 of Appendix 1 of Attachment C to Appendix D and Table 2-1 of Attachment A to Appendix D.
- NRDP, 2016. Butte Reduction Works Smelter Site Draft Test Pit Report. Natural Resource Damage Program. September 2016.

DESIGN PURPOSE KEY	
Abbreviation	Definition
GI	Geotechnical Investigation
GWC	Groundwater Characterization
HC	Hydrocarbons
PCB	Polychlorinated biphenyls
PCP	Pentachlorophenol
SPLP	(Synthetic Precipitation Leaching Procedure) Potential SPLP Sample Locations
SS	Sediment Sampling
SWC	Surface Water Characterization
WC	Solid Materials/Waste Characterization

Table 4
Schedule

ID	Task Name	Duration	Start	Finish	Notes	Schedule																					
						Qtr 2, 2021	Qtr 3, 2021	Qtr 4, 2021	Qtr 1, 2022	Qtr 2, 2022	Qtr 3, 2022																
						May	Jun	Jul	Aug	Sep	Oct	Nov	Dec	Jan	Feb	Mar	Apr	May	Jun	Jul	Aug	Sep					
0	Phase III QAPP Schedule	348 days	Thu 5/27/21	Mon 9/26/22		[Gantt bar from May 2021 to Sep 2022]																					
1	Installation/Development of Additional Piezometers	29.5 days	Mon 6/7/21	Fri 7/16/21	Completed	[Gantt bar from Mon 6/7/21 to Fri 7/16/21]																					
2	Field Work	2 days	Mon 6/7/21	Tue 6/8/21	Completed	[Gantt bar from Mon 6/7/21 to Tue 6/8/21]																					
3	Lab Analysis	5.5 wks	Wed 6/9/21	Fri 7/16/21	Completed	[Gantt bar from Wed 6/9/21 to Fri 7/16/21]																					
4	Installation of Additional Boreholes & Sampling/Geotech	147 days	Tue 7/6/21	Wed 1/26/22	Completed	[Gantt bar from Tue 7/6/21 to Wed 1/26/22]																					
5	Field Work	22 days	Tue 7/6/21	Wed 8/4/21	Completed	[Gantt bar from Tue 7/6/21 to Wed 8/4/21]																					
6	SPLP Sampling	85 days	Thu 8/5/21	Wed 12/1/21	Completed	[Gantt bar from Thu 8/5/21 to Wed 12/1/21]																					
7	Eurofins Lab Analysis	3.2 wks	Wed 12/1/21	Wed 12/22/21	Completed	[Gantt bar from Wed 12/1/21 to Wed 12/22/21]																					
8	Pioneer Materials Lab Analysis (Geotech)	25 wks	Thu 8/5/21	Wed 1/26/22	Completed	[Gantt bar from Thu 8/5/21 to Wed 1/26/22]																					
9	High-Groundwater Sampling	37 days	Thu 5/27/21	Fri 7/16/21	Completed	[Gantt bar from Thu 5/27/21 to Fri 7/16/21]																					
10	Sampling (Estimated)	17 days	Thu 5/27/21	Fri 6/18/21	Completed	[Gantt bar from Thu 5/27/21 to Fri 6/18/21]																					
11	Lab Analysis	4 wks	Mon 6/21/21	Fri 7/16/21	Completed	[Gantt bar from Mon 6/21/21 to Fri 7/16/21]																					
12	Additional SPLP Sampling	21 days	Thu 8/25/22	Thu 9/22/22	Dependent on Agency approval of 2022 Phase III QAPP.	[Gantt bar from Thu 8/25/22 to Thu 9/22/22]																					
13	Sample Shipping	1 day	Thu 8/25/22	Thu 8/25/22	Samples are already collected. Assuming we only need to ship them.	[Gantt bar from Thu 8/25/22 to Thu 8/25/22]																					
14	Lab Analysis	4 wks	Fri 8/26/22	Thu 9/22/22		[Gantt bar from Fri 8/26/22 to Thu 9/22/22]																					
15	Silver Bow Creek Sediment Sampling	23 days	Thu 8/25/22	Mon 9/26/22	Dependent on Agency approval of 2022 Phase III QAPP.	[Gantt bar from Thu 8/25/22 to Mon 9/26/22]																					
16	Field Work (Survey and Sampling)	3 days	Thu 8/25/22	Mon 8/29/22		[Gantt bar from Thu 8/25/22 to Mon 8/29/22]																					
17	Lab Analysis	4 wks	Tue 8/30/22	Mon 9/26/22		[Gantt bar from Tue 8/30/22 to Mon 9/26/22]																					

Project: Phase III QAPP Schedule
Date: Fri 4/8/22

Summary Progress		Milestone		Inactive Task		Manual Task		Manual Summary		External Tasks		Progress	
Task		Summary		Inactive Milestone		Duration-only		Start-only		External Milestone		Manual Progress	
Split		Project Summary		Inactive Summary		Manual Summary Rollup		Finish-only		Deadline			

Table 5. Precision, Accuracy and Completeness Calculation Equations

Characteristic	Formula	Symbols
Precision (as relative percent difference, RPD)	$RPD = \frac{(x_i - x_j)}{\left(\frac{x_i + x_j}{2}\right)} \times 100$	x_i, x_j : replicate values of x
Precision (as relative standard deviation, RSD, otherwise known as coefficient of variation)	$RSD = \frac{\sigma}{\bar{x}} \times 100$	σ : sample standard deviation \bar{x} : sample mean
Accuracy (as percent recovery, R, for samples without a background level of the analyte, such as reference materials, laboratory control samples and performance evaluation samples)	$R = \frac{x}{t} \times 100$	x : sample value t : true or assumed value
Completeness (as a percentage, C)	$C = \frac{n}{N} \times 100$	n : number of valid data points produced N : total number of samples taken

Table 6. Sample Collection, Preservation, and Holding Times

Analytical Group	Analytical Lab/Company ¹	Analyte	Analytical Method	Lab Reporting Limit	Lab Method Detection Limit ²	Holding Time	Container Size	Preservation ³	Justification			
Groundwater and Surface Water Field Parameters												
(1)	Pioneer	Water level	NA	NA	NA	NA	NA	NA	Determine depth-to-water to monitor seasonal groundwater and surface water conditions.			
(2a)	Pioneer	Temperature	NA	NA	NA	NA	NA	NA	Determine general stabilization parameters during sampling activities.			
		Specific conductance (SC)										
		Dissolved Oxygen (DO)										
		pH										
		Oxidation Reduction Potential (ORP)										
		Turbidity										
(2b)	Pioneer	Modern Water RaPID Assay Pentachlorophenol (PCP)	NA	NA	NA	7 Days	NA	NA	Identify any pre-existing concentrations of PCP to the west of the Site.			
Groundwater and Surface Water Laboratory Samples												
(3)	Eurofins TestAmerica	Total recoverable and dissolved arsenic (As)	EPA 200.8 (Rev 5.4)	0.5 µg/L	0.204 µg/L	180 Days	2, 250-mL high-density polyethylene (HDPE) bottles	Acidified with HNO ₃ (1) bottle field filtered with 0.45 µm filter (dissolved).	Define the effect of seasonal groundwater conditions on unimpacted and impacted groundwater.			
		Total recoverable and dissolved cadmium (Cd)		0.4 µg/L	0.037 µg/L							
		Total recoverable and dissolved copper (Cu)		1 µg/L	0.603 µg/L							
		Total recoverable and dissolved iron (Fe)		50 µg/L	13.3 µg/L							
		Total recoverable and dissolved lead (Pb)		0.4 µg/L	0.04 µg/L							
		Total recoverable and dissolved silver (Ag)		0.15 µg/L	0.025 µg/L							
		Total recoverable and dissolved zinc (Zn)		2 µg/L	0.928 µg/L							
		Total recoverable and dissolved mercury (Hg)	EPA 1631E	0.0005 µg/L	0.00014 µg/L					28 Days	2 Mercury Low Level Sample Kits (Provided by Eurofins TestAmerica)	Raw, Dissolved sample kit field filtered with 0.45 µm filter.
		Total recoverable Phosphate (PO ₄)	EPA 365.1	250 µg/L	95 µg/L					28 Days	1, 250-mL HDPE bottle	Acidified with H ₂ SO ₄ .
		Nitrate (NO ₂) and Nitrite (NO ₃)	EPA 353.2	100 µg/L	60 µg/L					28 Days	1, 250-mL HDPE bottle	Acidified with H ₂ SO ₄ .
(4)	Eurofins TestAmerica	Dissolved Calcium (Ca)	EPA 200.7 (Rev 4.4)	500 µg/L	33.7 µg/L	180 Days	250-mL HDPE bottle	Acidified with HNO ₃ , field filtered with 0.45 µm filter (dissolved).	Provide additional delineation on interactions with surrounding surface water and groundwater.			
		Dissolved Potassium (K)		3,300 µg/L	174 µg/L							
		Dissolved Silica (SiO ₂)		200 µg/L	136 µg/L							
		Dissolved Sodium (Na)		500 µg/L	85.9 µg/L							
		Dissolved Boron (B)		500 µg/L	41 µg/L							
		Dissolved Cobalt (Co)		20 µg/L	0.5 µg/L							
		Dissolved Magnesium (Mg)		500 µg/L	47.4 µg/L							
		Lithium (Li)		100 µg/L	16.9 µg/L							
		Dissolved Aluminum (Al)	EPA 200.8 (Rev 5.4)	40 µg/L	5.78 µg/L							
		Dissolved Barium (Ba)		1.2 µg/L	0.212 µg/L							
		Dissolved Manganese (Mn)		2 µg/L	0.459 µg/L							
		Dissolved Molybdenum (Mo)		0.8 µg/L	0.027 µg/L							
		Dissolved Nickel (Ni)		2.0 µg/L	0.125 µg/L							
		Dissolved Strontium (Sr)		0.40 µg/L	0.039 µg/L							
		Dissolved Cerium (Ce)		4 µg/L	0.0850 µg/L							
		Dissolved Palladium (Pd)		10.0 µg/L	0.444 µg/L							
		Dissolved Rubidium (Rb)		10 µg/L	0.915 µg/L							
		Total Hardness	Calculation	1.1 mg/L	0.0037 mg/L					14 Days	250-mL HDPE bottle	Raw
		Bicarbonate (HCO ₃)	SM 2320B	5 mg/L	5 mg/L							
		Carbonate (CO ₃)		5 mg/L	5 mg/L							
		Alkalinity, Total (as CaCO ₃)		5 mg/L	5 mg/L							
		Chloride (Cl)	EPA 300.0	1.5 mg/L	0.43 mg/L							
		Sulfate (SO ₄)		1.5 mg/L	0.8 mg/L							
		Fluoride (F)		0.20 mg/L	0.03 mg/L							
		Total Dissolved Solids (TDS)	SM2540C	10 mg/L	10 mg/L					7 days	1-L HDPE bottle	Raw
(5)	Eurofins TestAmerica	Polychlorinated biphenyls (PCB)	EPA 8082A	0.45 µg/L	0.08 µg/L	7 Days	2, 250 mL amber glass	Raw	Identify if PCB, PCP, Dioxins and/or any similar compounds exists in and near the BRW area at concentrations above regulatory limits. Determine if any of the similar compounds are present in sufficient quantities to interfere with field and/or laboratory detection.			
		Pentachlorophenol (PCP)	EPA 8270E SIM	1.00 µg/L	0.18 µg/L	7 Days	2, 250 mL amber glass	Raw				
		2,3,4,6-Tetrachlorophenol	EPA 8270E	0.6 µg/L	0.1 µg/L	7 Days	2-1L amber glass	Raw				
		2,3,5,6-Tetrachlorophenol		0.4 µg/L	0.07 µg/L							
		2,4,6-Trichlorophenol		0.6 µg/L	0.1 µg/L							
		2,4-Dichlorophenol		1 µg/L	0.2 µg/L							
		2-Chlorophenol		1 µg/L	0.05 µg/L							
		2,3,7,8-TCDD	EPA 1613B	10 pg/L	Sample Specific					1 Year	2-1L amber glass	Raw
		2,3,7,8-TCDF		10 pg/L								
		1,2,3,7,8-PeCDD		50 pg/L								
		1,2,3,7,8-PeCDF		50 pg/L								
		2,3,4,7,8-PeCDF		50 pg/L								
		1,2,3,4,7,8-HxCDD		50 pg/L								
		1,2,3,6,7,8-HxCDD		50 pg/L								
		1,2,3,7,8,9-HxCDD		50 pg/L								
		1,2,3,4,7,8-HxCDF		50 pg/L								
		1,2,3,6,7,8-HxCDF		50 pg/L								
		1,2,3,7,8,9-HxCDF		50 pg/L								
		2,3,4,6,7,8-HxCDF		50 pg/L								
		1,2,3,4,6,7,8-HpCDD		50 pg/L								
1,2,3,4,6,7,8-HpCDF		50 pg/L										
1,2,3,4,7,8,9-HpCDF		50 pg/L										
OCDD		100 pg/L										
OCDF		100 pg/L										
(6)	Eurofins TestAmerica	Volatile Petroleum Hydrocarbons (VPH)	MT VPH			14 Days	3, 40-mL clear glass VOA vials	Unfiltered, acidified with HCl	Identify if hydrocarbons exist in and near the BRW area at concentrations above regulatory action limits, and determine breakdown of petroleum components.			
		Extractable Petroleum Hydrocarbons (EPH) Fractionation	MT EPH			14 Days	2, 1-L amber glass	Unfiltered, acidified with HCl				
		Polycyclic Aromatic Hydrocarbons (PAHs)	EPA 8270E SIM			7 Days	2, 250-mL amber glass	Raw				
		1, 2 dichloroethane (1,2 DCA)	EPA 8260D			14 Days	3, 40-mL clear glass VOA vials	Unfiltered, acidified with HCl				
		1, 2 dibromoethane (EDB)	EPA 8011			14 Days	3, 40-mL clear glass VOA vials	Unfiltered, preserved with Sodium Thiosulfate				
(7)	Montana Bureau of Mines and Geology (MBMG)	Radon	EPA 913.0	20 pCi/L	Sample Specific	48 hours	125-mL glass - no headspace	Raw	Determine the flux of groundwater to surface water in Silver Bow Creek during high- and low-groundwater and surface water conditions.			

¹Atlantic Richfield may choose to use a different laboratory based on project needs. Regardless of the laboratory chosen, Atlantic Richfield will ensure the necessary reporting limits, required methodology, and the specified quality assurance/quality control and data validation requirements are followed as detailed in the Phase III QAPP. Agencies will be informed of any changes in the reporting limits, methodology, or the quality assurance/quality control and data validation procedures.

²Eurofins TestAmerica and MBMG will report results to the method detection limit. The analytical lab's reporting limits and detection limits are subject to change as these values are updated periodically to reflect analytical sensitivity and capability. Atlantic Richfield will ensure that any updates to the reporting limits or detection limits do not affect the ability for the Data Quality Objectives to be met and the updates will be specified in the Phase III Data Summary Report.

³In addition to the preservation listed, all samples will be cooled to <6 °C. Not all analyses require this but because multiple containers will be collected at most sites, all samples will be cooled.

⁴DEQ, 2017. Circular DEQ-7 Montana Numeric Water Quality Standards. Montana Department of Environmental Quality, May 2017.

⁵DEQ, 2018. Montana Risk-Based Corrective Action Guidance for Petroleum Releases, Montana Department of Environmental Quality, May 2018.

⁶3 days, if Shelby tubes are sealed with plastic caps and duct tape. The hold time can be extended by sealing the plastic caps with wax.

Units:
 pg/L - picograms per liter
 µg/L - microgram per liter
 mg/L - milligram per liter
 pCi/L - picocurie per liter
 S.U. - Standard Unit
 umhos/cm or µS/cm - microsiemen per centimeter
 mg/kg - milligram per kilogram

Table 6. Sample Collection, Preservation, and Holding Times

Analytical Group	Analytical Lab/Company ¹	Analyte	Analytical Method	Lab Reporting Limit	Lab Method Detection Limit ²	Holding Time	Container Size	Preservation ³	Justification	
LNAPL Laboratory Samples										
(8)	Eurofins TestAmerica	Volatile Petroleum Hydrocarbons (VPH)	MTVPH	Analyte Specific - DEQ Risk-Based Screening Level ⁴ where applicable.	0.01 S.U.	15 Minutes	4-oz. amber glass container	None	Identify the chemical components and concentrations of any LNAPL sample collected from BRW area.	
		Extractable Petroleum Hydrocarbons (EPH) Fractionation	MTEPH							
	Polycyclic Aromatic Hydrocarbons (PAHs)	EPA 8270E SIM								
	TBD	Hydrocarbon Fingerprinting Scan	If the interface probe indicates there is an LNAPL layer on the surface of the groundwater, An appropriate fingerprinting lab will be contacted to determine appropriate sampling and analytical methods. Agencies will be notified prior to collecting a sample.							
Soil Field Readings										
(9)	Pioneer XRF	Arsenic (As) Cadmium (Cd) Calcium (Ca) Chromium (Cr) Copper (Cu) Iron (Fe) Lead (Pb) Manganese (Mn) Mercury (Hg) Silver (Ag) Zinc (Zn)	NA	NA	NA	NA	NA	NA	Refine estimates of total metals in the BRW area.	
(10)	Pioneer PIDs MiniRAE (PID MR) - 10.6 eV lamp UltraRAE (PID UR) - 9.8 eV lamp	Volatile Organic Compounds	NA	NA	NA	NA	NA	NA	Screen soils for potential hydrocarbon impact. Refine estimates of hydrocarbons in the BRW area.	
Soil Laboratory Samples										
(11)	Eurofins TestAmerica General Parameters	pH	Method 9045D	0.01 S.U.	0.01 S.U.	15 Minutes	4-oz. amber glass container	None	Determine general chemistry of impacted materials in the BRW area.	
		SC	120.1	10 umhos/cm	8 umhos/cm	28 Days	8-oz. amber glass container	None		
	ICP-MS	Arsenic (As)	SW-846 6020B	0.25 mg/kg	0.05 mg/Kg	180 Days	4-oz. amber glass container	None	Refine estimates of total metals in the BRW area.	
		Cadmium (Cd)		0.4 mg/kg	0.0385 mg/Kg					
		Calcium (Ca)		50 mg/kg	3.12 mg/Kg					
		Chromium (Cr)		0.5 mg/kg	0.0315 mg/Kg					
		Copper (Cu)		0.5 mg/kg	0.110 mg/Kg					
		Iron (Fe)		20 mg/kg	5.77 mg/Kg					
		Lead (Pb)		0.25 mg/kg	0.0240 mg/Kg					
		Manganese (Mn)		0.55 mg/kg	0.227 mg/Kg					
		Silver (Ag)		0.1 mg/kg	0.01 mg/Kg					
		Zinc (Zn)		2.55 mg/kg	0.805 mg/Kg					
		Mercury (Hg)	EPA Method 7471A	0.03 mg/kg	0.009 mg/kg					28 Days
(12)	Eurofins TestAmerica	Volatile Petroleum Hydrocarbons (VPH) 1, 2 dichloroethane (1,2 DCA)	MTVPH EPA 8260D	Analyte Specific - Meets DEQ Risk-Based Screening Level ⁴ where applicable.	0.01 S.U.	15 Minutes	4-oz. amber glass container	None	Identify if hydrocarbons exist in the BRW area at concentrations above regulatory action limits. Identify if lead scavengers exist in the BRW area at concentrations above regulatory action limits.	
		Extractable Petroleum Hydrocarbons (EPH) Fractionation	MTEPH							7 Days
		Polycyclic Aromatic Hydrocarbons (PAHs)	EPA 8270E SIM							14 Days
		1, 2 dibromoethane (EDB)	EPA 8011							
(13)	Eurofins TestAmerica SPLP (20:1)	Arsenic (Dissolved)	SW1312 (20:1) Leachate to be analyzed by ICP-MS (SW-846 6020B). SPLP solids to be analyzed for As, Cd, Cu, Fe, Pb, Ag, Zn (SW-846 6020B)	5 µg/L	1.02 µg/L	180 Days	8-oz. amber glass container	None	Determine the leachability of COCs from impacted materials. The action level for the collection of SPLP samples from individual layers of alluvium from the Waste Characterization Boreholes is based on two criteria: (1) Is the sample coming from material that will not be removed (i.e., is located below and or adjacent to the extent of the current excavation surface)? and (2) Does the alluvial layer have a field XRF concentration for COCs which are relatively higher than the concentrations observed in the other lithological layers? If the answer to both of these questions are "yes," an SPLP sample will be collected.	
		Cadmium (Dissolved)		2 µg/L	0.185 µg/L					
		Copper (Dissolved)		10.0 µg/L	3.02 µg/L					
		Iron (Dissolved)		500 µg/L	66.7 µg/L					
		Lead (Dissolved)		2.00 µg/L	0.200 µg/L					
		Silver (Dissolved)		2.00 µg/L	0.125 µg/L					
		Zinc (Dissolved)		35.0 µg/L	4.64 µg/L					
		Laboratory to report final extraction pH and DO.		0.01 S.U.	0.01 S.U.					
(14)	Pioneer's Material Testing Laboratory	Moisture Content	ASTM D2216	NA	NA	10 Days	500 grams	None	Identify soil parameters for geotechnical analysis and liquefaction calculations. Determine sediment particle size distribution to guide calculations to determine the sediment transport capacity through the Site and assist in the design of the realigned Silver Bow Creek.	
		Resistivity	AASHTO T288			16 hours	1500 grams			
		pH	AASHTO T289			15 minutes	300 grams			
		Sulfate (SO4)	EPA Method 300 or MT 232-04			28 days	1 five gallon bucket			
		Particle Size Distribution	ASTM D6913			None	20000 grams. Approx. 3/4 of five gallon bucket			
		Atterberg Limits	ASTM D4318			None	200 grams			
		Standard Proctor	ASTM D698			None	30000 grams. Approx. 1 five gallon bucket			
		California Bearing Ratio	ASTM D1883			None	2 five gallon buckets			
		Consolidated Undrained Triaxial Compression	ASTM D4767							
		Consolidation of Soils	ASTM D2435			3 days ⁶	1 Shelby tube			

¹Atlantic Richfield may choose to use a different laboratory based on project needs. Regardless of the laboratory chosen, Atlantic Richfield will ensure the necessary reporting limits, required methodology, and the specified quality assurance/quality control and data validation requirements are followed as detailed in the Phase III QAPP. Agencies will be informed of any changes in the reporting limits, methodology, or the quality assurance/quality control and data validation procedures.

²Eurofins TestAmerica and MBMG will report results to the method detection limit. The analytical lab's reporting limits and detection limits are subject to change as these values are updated periodically to reflect analytical sensitivity and capability. Atlantic Richfield will ensure that any updates to the reporting limits or detection limits do not affect the ability for the Data Quality Objectives to be met and the updates will be specified in the Phase III Data Summary Report.

³In addition to the preservation listed, all samples will be cooled to <6 °C. Not all analyses require this but because multiple containers will be collected at most sites, all samples will be cooled.

⁴DEQ, 2017. Circular DEQ-7 Montana Numeric Water Quality Standards. Montana Department of Environmental Quality, May 2017.

⁵DEQ, 2018. Montana Risk-Based Corrective Action Guidance for Petroleum Releases, Montana Department of Environmental Quality, May 2018.

⁶3 days, if Shelby tubes are sealed with plastic caps and duct tape. The hold time can be extended by sealing the plastic caps with wax.

Units:
 pg/L - picograms per liter
 µg/L - microgram per liter
 mg/L - milligram per liter
 pCi/L - picocurie per liter
 S.U. - Standard Unit
 umhos/cm or µS/cm - microsiemen per centimeter
 mg/kg - milligram per kilogram

Table 7. Phase III Site Investigation Locations

Location	Design Purpose	Northing (Approximate)	Easting (Approximate)	Target Depth (ft)	Installation Method	Measuring Point Elevation	Solid Material Characterization (Analytical Group from Table 6)	Geotechnical Investigation (Analytical Group From Table 6)	Groundwater Characterization and Loading Analysis		
									Analytical Group From Table 6	Monthly Manual Water Levels ³	Transducer ³
Proposed Solid Material Characterization Boreholes²											
BRW21-BH42	HC/WC/SPLP	651397.52	1194830.88	Depth of each borehole will extend to bedrock, or as determined by field personnel.	Geoprobe/Sonic	TBD	9, 10, 11, 12, 13	-	-	-	-
BRW21-BH43	HC/WC/SPLP	651187.48	1194740.06		Geoprobe/Sonic	TBD	9, 10, 11, 12, 13	-	-	-	-
BRW21-BH44	HC/WC/SPLP	651434.42	1196505.17		Geoprobe/Sonic	TBD	9, 10, 11, 12, 13	-	-	-	-
BRW21-BH45	HC/WC/SPLP	651499.89	1196453.01		Geoprobe/Sonic	TBD	9, 10, 11, 12, 13	-	-	-	-
BRW21-BH46	HC/WC/SPLP	651570.88	1196128.35		Geoprobe/Sonic	TBD	9, 10, 11, 12, 13	-	-	-	-
Proposed Geotechnical Boreholes											
BRW21-BH30	GI	651522.32	1195715.04	Depth of each borehole will extend to bedrock, or as determined by field personnel.	Geoprobe/Sonic/HSA	TBD	-	14	-	-	-
BRW21-BH31	GI	651508.06	1195798.35		Geoprobe/Sonic/HSA	TBD	-	14	-	-	-
BRW21-BH32	GI	651643.61	1195694.21		Geoprobe/Sonic/HSA	TBD	-	14	-	-	-
BRW21-BH33	GI	651612.57	1195869.07		Geoprobe/Sonic/HSA	TBD	-	14	-	-	-
BRW21-BH34	GI	651079.36	1194856.27		Geoprobe/Sonic/HSA	TBD	-	14	-	-	-
BRW21-BH35	GI	651106.73	1195133.63		Geoprobe/Sonic/HSA	TBD	-	14	-	-	-
BRW21-BH36	GI	651136.36	1195350.86		Geoprobe/Sonic/HSA	TBD	-	14	-	-	-
BRW21-BH37	GI	651300.19	1195341.10		Geoprobe/Sonic/HSA	TBD	-	14	-	-	-
BRW21-BH38	GI	651132.34	1195692.49		Geoprobe/Sonic/HSA	TBD	-	14	-	-	-
BRW21-BH39	GI	651253.10	1195545.04		Geoprobe/Sonic/HSA	TBD	-	14	-	-	-
BRW21-BH40	GI	651222.32	1196111.99		Geoprobe/Sonic/HSA	TBD	-	14	-	-	-
BRW21-BH41	GI	651294.79	1196458.61		Geoprobe/Sonic/HSA	TBD	-	14	-	-	-
Proposed Phase III Piezometers											
BRW21-PZ51	HC/OP/GWC	651131.82	1194329.22	Depth of each borehole will extend to bedrock, or as determined by field personnel. Piezometer screens will be installed in the shallowest conductive unit, as determined by the field team leader in consultation with the QAO.	Geoprobe/Sonic	TBD	9, 10, 11, 12, 13	-	1, 2a, 2b, 3, 4, 5, 6, 7, 8 ^{1,4}	X	X
BRW21-PZ52	HC/OP/GWC	651131.30	1194329.14		Geoprobe/Sonic	TBD	9, 10, 11, 12, 13	-	1, 2a, 2b, 3, 4, 5, 6, 8 ¹	X	X
Phase III Staff Gages (Installed as part of BRW Phase II QAPP RFC 01)											
HCC-00-C	SWC	651337.99	1194040.66	Staff gage installed to prevent movement during high flow.	-	5430.87	-	-	1 ⁴	-	-
HCC-01A1	SWC	651308.42	1193378.50		-	5428.72	-	-	1 ⁴	-	-
HCC-00-B	SWC	651376.28	1194594.26		-	5432.75	-	-	1 ⁴	-	-
HCC-00-A	SWC	651572.97	1194913.50		-	5433.84	-	-	1 ⁴	-	-
Hydrocarbon Monitoring Wells											
BRW19-HCW30	HC/OP/GWC	651450.51	1195374.60	Previously Installed	Previously Installed	5452.08	-	-	1, 2a, 3, 5, 6, 8 ¹	X	-
BRW19-HCW31	GWC	651587.17	1195529.21			5448.68	-	-	-	X	-
BRW19-HCW32	GWC	651556.21	1195703.74			5451.85	-	-	-	X	-
BRW19-HCW33R	GWC	651518.73	1195856.52			5450.07	-	-	-	X	-
BRW19-HCW34	GWC	651484.16	1195915.52			5449.93	-	-	-	X	-
BRW19-HCW35	HC/OP/GWC	651388.39	1195992.91			5450.74	-	-	1, 2a, 3, 5, 6, 8 ¹	X	-
BRW19-HCW36	GWC	651213.42	1196092.76			5449.04	-	-	-	X	-
BRW19-HCW37	GWC	651247.07	1195537.85			5452.52	-	-	1, 2a, 3, 5, 6, 8 ¹	X	-
BRW19-HCW38	HC/OP/GWC	651319.59	1195542.24			5448.49	-	-	1, 2a, 3, 5, 6, 8 ¹	X	-
BRW19-HCW39	GWC	651381.32	1195720.77			5447.93	-	-	-	X	-
BRW19-HCW40	GWC	651172.99	1195824.47			5447.05	-	-	-	X	-
BRW19-HCW41	HC/OP/GWC	651297.44	1196317.74			5447.89	-	-	1, 2a, 3, 5, 6, 8 ¹	X	-
BRW19-HCW42	HC/OP/GWC	651111.54	1195564.83			5446.22	-	-	1, 2a, 3, 5, 6, 8 ¹	X	-

¹ Only test for LNAPL (Group (8)) if the interface probe indicates there is an LNAPL layer on the surface of the groundwater. Once the LNAPL layer has been sampled, bail out the LNAPL and use low flow sampling to take samples for Group (3) dissolved only. If the interface probe shows no presence of LNAPL, take samples as indicated in the SOPs.

² Hydrocarbon Sampling: At the discretion of the Field Team Leader, take a soil sample and test for hydrocarbons (Group (12)) at the capillary zone. If field personnel have a positive PID reading in the soil cuttings and Field Team Leader determines appropriate, take a soil sample (Group (12)) at that interval.

³ Transducers implemented during the Phase I Site Investigation will be used during Phase III Site Investigation to measure water levels in approximately 20 locations as determined by the Field Team Leader and CPM in consultation with the Contractor QAO. Additional transducers may be added, or locations may be modified based on specific design-related needs. Manual water elevation measurements from Phase I will continue through Phase III as well.

⁴ Sample groundwater locations, surface water locations, and measure staff gages within the same day for the Silver Bow Creek Loading Analysis.

Table 7. Phase III Site Investigation Locations

Location	Design Purpose	Northing (Approximate)	Easting (Approximate)	Target Depth (ft)	Installation Method	Measuring Point Elevation	Solid Material Characterization (Analytical Group from Table 6)	Geotechnical Investigation (Analytical Group From Table 6)	Groundwater Characterization and Loading Analysis		
									Analytical Group From Table 6	Monthly Manual Water Levels ³	Transducer ³
2018 and 2019 Piezometers											
BRW18-PZ01	GWC	651078.74	1194833.30	Previously Installed	Previously Installed	5442.51	-	-	1, 2a, 2b, 3, 5, 8 ¹	X	-
BRW19-PZ01S	HC/OP/GWC	651080.94	1194840.03			5442.48	-	-	1, 2a, 2b, 3, 5, 6, 8 ¹	X	-
BRW19-PZ01DR	OP/GWC	651085.48	1194837.20			5441.75	-	-	1, 2a, 2b, 3, 5, 8 ¹	X	-
BRW18-PZ02	GWC	651239.59	1195014.45			5440.44	-	-	1, 2a, 3, 4, 7, 8 ^{1,4}	X	-
BRW18-PZ03	GWC	651357.94	1195110.57			5441.04	-	-	1, 2a, 3, 4, 7, 8 ^{1,4}	X	-
BRW19-PZ03D	GWC	651359.05	1195104.76			5440.98	-	-	1, 2a, 3, 8 ¹	X	-
BRW18-PZ04	GWC	651390.83	1195150.38			5441.37	-	-	1, 2a, 3, 8 ¹	X	-
BRW18-PZ05	GWC	651430.31	1195183.84			5441.63	-	-	-	X	X
BRW19-PZ05S	GWC	651425.33	1195185.47			5441.44	-	-	1, 2a, 3, 8 ¹	X	-
BRW18-PZ06	GWC	651445.38	1195134.85			5441.45	-	-	1, 2a, 3, 8 ¹	X	-
BRW18-PZ08	GWC	651510.98	1195233.98			5443.77	-	-	1, 2a, 3, 8 ¹	X	-
BRW18-PZ09	GWC	651605.22	1195255.40			5441.70	-	-	1, 2a, 3, 4, 7, 8 ^{1,4}	X	X
BRW18-PZ10	HC/OP/GWC	651099.62	1195378.38			5448.72	-	-	1, 2a, 3, 5, 6, 8 ¹	X	-
BRW19-PZ10D	OP/GWC	651103.74	1195375.07			5448.70	-	-	1, 2a, 3, 5, 8 ¹	X	-
BRW18-PZ11	GWC	651107.61	1195553.96			5447.87	-	-	1, 2a, 3, 8 ¹	X	-
BRW19-PZ11S	GWC	651110.55	1195548.13			5448.40	-	-	1, 2a, 3, 8 ¹	X	-
BRW18-PZ12	HC/OP/GWC	651169.20	1195817.94			5448.99	-	-	1, 2a, 3, 5, 6, 8 ¹	X	X
BRW19-PZ12D	OP/GWC	651170.37	1195813.31			5449.78	-	-	1, 2a, 3, 5, 8 ¹	X	-
BRW18-PZ13	HC/OP/GWC	651208.55	1196088.55			5450.49	-	-	1, 2a, 3, 5, 6, 8 ¹	X	-
BRW18-PZ14	HC/OP/GWC	651342.37	1196560.24			5448.88	-	-	1, 2a, 3, 5, 6, 8 ¹	X	-
BRW18-PZ15	GWC	651437.61	1196565.88			5448.24	-	-	1, 2a, 3, 8 ¹	X	X
BRW18-PZ16	GWC	651547.25	1196380.33			5461.92	-	-	-	X	-
BRW19-PZ16S	GWC	651542.73	1196380.43			5461.70	-	-	1, 2a, 3, 8 ¹	X	-
BRW18-PZ17	GWC	651415.53	1196291.03			5448.56	-	-	1, 2a, 3, 8 ¹	X	-
BRW18-PZ18	GWC	651380.51	1195727.67			5449.74	-	-	1, 2a, 3, 8 ¹	X	-
BRW18-PZ19	GWC	651521.13	1195774.28			5454.82	-	-	-	X	-
BRW18-PZ20	GWC	651321.48	1195549.12			5451.47	-	-	-	X	-
BRW18-PZ21	HC/GWC	651255.68	1195537.42			5455.08	-	-	1, 2a, 3, 6, 8 ¹	X	-
BRW18-PZ22	GWC	651453.87	1195379.49			5453.88	-	-	-	X	-
BRW18-PZ23	GWC	651584.45	1195523.49			5450.55	-	-	-	X	-
BRW18-PZ24	GWC	651802.85	1195648.06			5460.15	-	-	1, 2a, 3, 8 ¹	X	-
BRW18-PZ25	GWC	651508.01	1194940.45			5440.46	-	-	1, 2a, 3, 8 ¹	X	-
BRW19-PZ26	GWC	651265.10	1194828.94			5439.55	-	-	1, 2a, 3, 8 ¹	X	-
BRW19-PZ27	GWC	651271.93	1194908.24			5440.64	-	-	1, 2a, 3, 8 ¹	X	-
BRW19-PZ28R	GWC	651216.85	1195101.83			5441.41	-	-	-	X	-
BRW19-PZ29	GWC	651173.47	1195199.34			5448.17	-	-	-	X	-
BRW19-PZ30	GWC	651173.59	1194932.55			5440.57	-	-	1, 2a, 3, 8 ¹	X	-
BRW19-PZ31	GWC	651309.76	1195071.65			5440.94	-	-	-	X	-
BRW19-PZ32	GWC	651238.96	1194999.89			5443.23	-	-	1, 2a, 3, 8 ¹	X	-
BRW19-PZ40	GWC	651273.72	1195274.43			5449.87	-	-	-	X	-
BRW19-PZ41	GWC	651259.65	1195465.01			5453.49	-	-	-	X	-

¹ Only test for LNAPL (Group (8)) if the interface probe indicates there is an LNAPL layer on the surface of the groundwater. Once the LNAPL layer has been sampled, bail out the LNAPL and use low flow sampling to take samples for Group (3) dissolved only. If the interface probe shows no presence of LNAPL, take samples as indicated in the SOPs.

² Hydrocarbon Sampling: At the discretion of the Field Team Leader, take a soil sample and test for hydrocarbons (Group (12)) at the capillary zone. If field personnel have a positive PID reading in the soil cuttings and Field Team Leader determines appropriate, take a soil sample (Group (12)) at that interval.

³ Transducers implemented during the Phase I Site Investigation will be used during Phase III Site Investigation to measure water levels in approximately 20 locations as determined by the Field Team Leader and CPM in consultation with the Contractor QAO. Additional transducers may be added, or locations may be modified based on specific design-related needs. Manual water elevation measurements from Phase I will continue through Phase III as well.

⁴ Sample groundwater locations, surface water locations, and measure staff gages within the same day for the Silver Bow Creek Loading Analysis.

Table 7. Phase III Site Investigation Locations

Location	Design Purpose	Northing (Approximate)	Easting (Approximate)	Target Depth (ft)	Installation Method	Measuring Point Elevation	Solid Material Characterization (Analytical Group from Table 6)	Geotechnical Investigation (Analytical Group From Table 6)	Groundwater Characterization and Loading Analysis		
									Analytical Group From Table 6	Monthly Manual Water Levels ³	Transducer ³
2018 and 2019 Piezometers (Cont.)											
BRW19-PZ42	HC/GWC	651323.16	1195509.96	Previously Installed	Previously Installed	5451.14	-	-	1, 2a, 3, 6, 8 ¹	X	-
BRW19-PZ43	GWC	651231.79	1195611.59			5448.78	-	-	-	X	-
BRW19-PZ44	GWC	651201.50	1195576.03			5449.19	-	-	-	X	-
BRW19-PZ45	GWC	651250.06	1195802.41			5449.30	-	-	1, 2a, 3, 8 ¹	X	-
BRW19-PZ46	HC/OP/GWC	651061.56	1194745.18			5444.40	-	-	1, 2a, 2b, 3, 4, 5, 6, 7, 8 ^{1,4}	X	-
BRW19-PZ47	HC/OP/GWC	651091.05	1195030.30			5446.46	-	-	1, 2a, 2b, 3, 5, 6, 8 ¹	X	-
BRW19-PZ48	HC/OP/GWC	651136.33	1195673.99			5448.79	-	-	1, 2a, 3, 5, 6, 8 ¹	X	-
BRW19-PZ49	HC/OP/GWC	651189.20	1195955.66			5450.52	-	-	1, 2a, 3, 5, 6, 8 ¹	X	-
BRW19-PZ50	HC/OP/GWC	651158.97	1195757.20			5449.24	-	-	1, 2a, 3, 5, 6, 8 ¹	X	-
Existing Surface Water Locations											
B-6	SWC	651432.38	1194969.09	Previously Installed	Previously Installed	5435.08	-	-	1, 2a, 3, 4, 7 ⁴	-	-
BRW-SS-01	SWC	651135.65	1194636.57			5434.31	-	-	1, 2a, 3, 4, 7 ⁴	-	-
B-5	SWC	651145.42	1193887.10			5431.81	-	-	1, 2a, 3, 4, 7 ⁴	-	-
SS-04	SWC	651043.32	1197358.41			5441.22	-	-	-	X	-
SS-05	SWC	651486.68	1196597.16			5440.64	-	-	-	X	X
SS-05.6	SWC	651869.30	1195726.02			5437.82	-	-	-	X	-
SS-05.7	SWC	651873.93	1195681.57			5437.38	-	-	-	X	-
SS-05.9R	SWC	651837.15	1195584.49			5437.52	-	-	-	X	-
SS-05A	SWC	651698.56	1195316.48			5436.41	-	-	1, 2a, 3, 4, 7 ⁴	X	X
SS-05B	SWC	651538.68	1195129.45			5436.13	-	-	1, 2a, 3, 4, 7 ⁴	X	-
SBC Sed B-8	SWC	651690.29	1196322.31			5438.24	-	-	-	X	X
SS-06A	SWC	651180.07	1192651.80			5431.00	-	-	1, 2a, 3, 4, 7 ⁴	-	-
BRW-00	SWC	651757.70	1194972.44			5443.65	-	-	1, 2a, 3, 4, 7 ⁴	X	X
Existing Monitoring Wells											
AMW-02	GWC	651600.33	1196999.20	Previously Installed	Previously Installed	5452.54	-	-	-	X	-
BPS07-08A	GWC	651929.32	1196286.30			5450.47	-	-	-	X	-
BPS07-13A	GWC	651644.07	1196257.93			5463.58	-	-	-	X	X
BPS07-13B	GWC	651647.09	1196252.70			5464.70	-	-	-	X	X
BPS07-14A	GWC	651801.25	1195646.00			5459.52	-	-	-	X	X
BPS07-15A	GWC	651691.02	1195953.51			5459.33	-	-	-	X	X
BPS07-25	GWC	651930.29	1195699.87			5449.08	-	-	-	X	X
BPS11-01	GWC	652032.37	1196519.82			5450.08	-	-	-	X	-
BPS11-02	GWC	651688.16	1196542.27			5447.27	-	-	-	X	-
BPS11-05A1	GWC	651319.58	1196512.37			5449.38	-	-	-	X	X
BPS11-05A2	GWC	651322.72	1196521.57			5449.46	-	-	-	X	X
BPS11-06	GWC	651447.56	1196042.04			5452.05	-	-	-	X	X
BPS11-07	GWC	652017.09	1195871.59			5455.46	-	-	-	X	-
BPS11-08	GWC	652318.31	1196084.17			5456.82	-	-	-	X	-
BPS11-09	GWC	651018.77	1197015.15			5448.20	-	-	-	X	-

¹ Only test for LNAPL (Group (8)) if the interface probe indicates there is an LNAPL layer on the surface of the groundwater. Once the LNAPL layer has been sampled, bail out the LNAPL and use low flow sampling to take samples for Group (3) dissolved only. If the interface probe shows no presence of LNAPL, take samples as indicated in the SOPs.

² Hydrocarbon Sampling: At the discretion of the Field Team Leader, take a soil sample and test for hydrocarbons (Group (12)) at the capillary zone. If field personnel have a positive PID reading in the soil cuttings and Field Team Leader determines appropriate, take a soil sample (Group (12)) at that interval.

³ Transducers implemented during the Phase I Site Investigation will be used during Phase III Site Investigation to measure water levels in approximately 20 locations as determined by the Field Team Leader and CPM in consultation with the Contractor QAO. Additional transducers may be added, or locations may be modified based on specific design-related needs. Manual water elevation measurements from Phase I will continue through Phase III as well.

⁴ Sample groundwater locations, surface water locations, and measure staff gages within the same day for the Silver Bow Creek Loading Analysis.

Table 7. Phase III Site Investigation Locations

Location	Design Purpose	Northing (Approximate)	Easting (Approximate)	Target Depth (ft)	Installation Method	Measuring Point Elevation	Solid Material Characterization (Analytical Group from Table 6)	Geotechnical Investigation (Analytical Group From Table 6)	Groundwater Characterization and Loading Analysis		
									Analytical Group From Table 6	Monthly Manual Water Levels ³	Transducer ³
Existing Monitoring Wells (cont.)											
BPS11-12A	GWC	650631.21	1197056.64	Previously Installed	Previously Installed	5452.35	-	-	-	X	-
FP98-01B	GWC	651510.42	1195275.85			5461.32	-	-	-	X	X
FP98-1	GWC	651477.17	1195210.87			5443.13	-	-	1, 2a, 3, 4, 7, 8 ^{1,4}	X	X
FP98-2	GWC	651577.81	1195030.65			5441.49	-	-	-	X	-
GS-13A	GWC	651974.41	1195561.75			5443.81	-	-	-	X	-
GS-13B	GWC	651978.13	1195542.63			5441.89	-	-	-	X	-
HCA-MG3	GWC	652262.56	1194778.68			5460.35	-	-	-	X	-
FP98-3	GWC	651126.85	1195161.74			5445.89	-	-	-	X	-
FP98-5	GWC	651316.64	1194489.87			5439.44	-	-	-	X	-
GS-29SR	GWC	651277.68	1196900.37			5448.85	-	-	-	X	-
MW-03-MPC	HC/OP/GWC	651110.26	1196245.85			5447.22	-	-	1, 2a, 3, 5, 6, 8 ¹	X	-
MW-03A-MPC	GWC	651103.31	1196232.69			5447.32	-	-	-	X	-
MW-02-MPC	GWC	650982.18	1195763.23			5447.23	-	-	-	X	-
MW-01-MPC	GWC	650964.97	1196145.41			5449.47	-	-	-	X	-
GW-13	HC/OP/GWC	651004.61	1194528.66			TBD	-	-	1, 2a, 2b, 3, 4, 5, 6, 8 ¹	X	-
GW-17	HC/OP/GWC	651004.61	1194528.66			TBD	-	-	1, 2a, 2b, 3, 4, 5, 6, 7, 8 ^{1,4}	X	-
MW-I-96	HC/OP/GWC	650900.38	1194210.56			5439.10	-	-	1, 2a, 2b, 3, 4, 5, 6, 8 ¹	X	-
MW-O-01	HC/OP/GWC	650632.17	1194160.27			5441.40	-	-	1, 2a, 2b, 3, 4, 5, 6, 8 ¹	X	-
Quality Assurance Samples											
Field Duplicate	Verify sampling procedures, 1 per 20 samples	-	-	-	-	-	11, 12, 13	-	2a, 2b, 3, 4, 5, 6, 7, 8	-	-
Equipment Blank	Verify equipment decontamination procedures, 1 per 20 samples	-	-	-	-	-	11, 12, 13	-	2a, 2b, 3, 4, 5, 6, 7, 8	-	-
Field Blank	Verify DI water concentrations, 1 per 20 samples	-	-	-	-	-	11, 12, 13	-	2a, 2b, 3, 4, 5, 6, 7, 8	-	-
XRF Blank	Monitor for cross contamination, 1 per 20 samples	-	-	-	-	-	9	-	-	-	-
XRF Standards	Check accuracy of XRF, 1 per 20 samples	-	-	-	-	-	9	-	-	-	-
XRF Duplicate Sample	Track precision of the XRF, and the homogeneity of the sample matrix, 1 per 20 samples	-	-	-	-	-	9	-	-	-	-
XRF Replicate Sample	Track precision of XRF, 1 per 20 samples	-	-	-	-	-	9	-	-	-	-

¹ Only test for LNAPL (Group (8)) if the interface probe indicates there is an LNAPL layer on the surface of the groundwater. Once the LNAPL layer has been sampled, bail out the LNAPL and use low flow sampling to take samples for Group (3) dissolved only. If the interface probe shows no presence of LNAPL, take samples as indicated in the SOPs.

² Hydrocarbon Sampling: At the discretion of the Field Team Leader, take a soil sample and test for hydrocarbons (Group (12)) at the capillary zone. If field personnel have a positive PID reading in the soil cuttings and Field Team Leader determines appropriate, take a soil sample (Group (12)) at that interval.

³ Transducers implemented during the Phase I Site Investigation will be used during Phase III Site Investigation to measure water levels in approximately 20 locations as determined by the Field Team Leader and CPM in consultation with the Contractor QAO. Additional transducers may be added, or locations may be modified based on specific design-related needs. Manual water elevation measurements from Phase I will continue through Phase III as well.

⁴ Sample groundwater locations, surface water locations, and measure staff gages within the same day for the Silver Bow Creek Loading Analysis.

Design Purpose Key		
Abbreviation	Definition	Notes
GI	Geotechnical Investigation	More boreholes may be drilled as end land use plan develops or if the geotechnical Additional samples may be collected from boreholes without the designated design purpose. Will depend on what is encountered in the field while sampling.
HC	Hydrocarbons	
OP	Organic Pollutants (OP)	
WC	Solid Materials/Waste Characterization	
SPLP	Potential SPLP Sample Location	
GWC	Groundwater Characterization	
SWC	Surface Water Characterization	

Table 8. Limit of Detection for XRF

Metals	EPA Method 6200 (mg/kg)	Niton XL3* (mg/kg)
Arsenic (As)	40	3
Cadmium (Cd)	100	7
Calcium (Ca)	70	26
Copper (Cu)	50	14
Chromium (Cr)	150	9
Iron (Fe)	60	28
Mercury (Hg)	30	10
Lead (Pb)	20	4
Manganese (Mn)	70	30
Silver (Ag)	70	12
Zinc (Zn)	50	7

*Niton XL3 limit of detection is based on acquisition time of 120 seconds analyzing a quartz-sand matrix. Actual in-field detection limits are typically higher due to soil matrix effects.
mg/kg: milligrams per kilogram.

Appendix A.

Standard Operating Procedures



**SOP-DE-01;
PERSONAL DECONTAMINATION
PROCEDURES**

DATE ISSUED:
12/03/2014
REVISION: 0
PAGE 1 of 6

PURPOSE	To provide standard instructions for decontamination of all personnel leaving a contaminated area.
SCOPE	This practice has been prepared for the Pioneer Technical Services, Inc. (Pioneer) workforce and applies to work carried out by and on behalf of Pioneer. All members of the Pioneer workforce who conduct the work shall be trained and competent in the risk-assessed work described below.

WORK INSTRUCTIONS

The following instructions are intended to provide sufficient guidance to perform the task in a safe, accurate, and reliable manner. Should these instructions present information that is inaccurate or unsafe, operations personnel must bring the issue to the attention of the Project Manager and the appropriate revisions made. All work carried under this SOP will be consistent with procedures and policies described in the appropriate Operation, Maintenance, and Monitoring (O&M) Plan (where applicable), appropriate Site-Specific Health and Safety Plan (SSHASP), and Pioneer Corporate Health and Safety Plan (HASP).

TASK	INSTRUCTIONS
1. Wash/ Remove outer contaminated items.	<p>Remove nitrile or latex gloves by grasping the outside of the opposite glove near the wrist. Pull and peel the glove away from the hand, turning the glove inside out with the contaminated side now on the inside. Hold the removed glove in the opposite gloved hand. Slide one or two fingers of the ungloved hand under the wrist of the remaining glove. Peel glove off from the inside, creating a bag for both gloves.</p> <p>If wearing protective coveralls such as Tyvec suites, brush built up material off the suit, only if in designated decontamination zone. Unzip the coverall and begin rolling that outwards, rolling it down over your shoulders. Place both hands behind your back and pull down each arm until completely removed. Sit down and remove each shoe then roll the coveralls down (ensuring the contaminated side is not touched or comes into contact with clothing) over your knees until completely removed.</p> <p>If there is not a designated decontamination zone, remove personal protective equipment (PPE) carefully to contain material and place it in the appropriate disposal container.</p> <p>For instructions to remove additional PPE not described in this document, refer to the project's HASP.</p> <p>Wash with soap (nonphosphate) and tap water the outer, more heavily contaminated items, such as boots. Rinse the items in tap water.</p>
2. Wash inner contaminated items.	If necessary, wash with soap (nonphosphate) and tap water the inner, less contaminated items. Rinse the items in tap water.
3. Store/ transport items.	Store/transport contaminated items in a separate designated area to prevent cross contamination prior to disposal.



**SOP-DE-01;
PERSONAL DECONTAMINATION
PROCEDURES**

DATE ISSUED:
12/03/2014
REVISION: 0
PAGE 2 of 6

4. Dispose of contaminated items.	Dispose of contaminated clothing and equipment in accordance with site/project, client, and/or federal and state requirements.
5. Contact the Safety and Health Manager.	For contaminants other than those found typically at uncontrolled hazardous waste sites, such as asbestos, PCB, PCE, etc. see the Safety and Health Manager.
Information about Emergency Decontamination	
1. During life-saving process.	If the decontamination procedure is essential to the life-saving process, decontamination must be performed immediately.
2. During heat-related illness.	If heat-related illness develops, protective clothing should be removed as soon as possible. Wash, rinse, and/or cut off protective clothing/equipment.
3. When medical treatment is needed.	<p>If medical treatment is required to save a life, decontamination should be delayed until the victim is stabilized. Wrap the victim to reduce contamination of others.</p> <p>Alert medical personnel to the emergency and instruct them about potential contamination. Instruct medical personnel about specific decontamination procedures.</p>



HSSE CONSIDERATIONS

This section to be completed with concurrence from the Safety and Health Manager.

<i>SOURCE</i>	<i>HAZARDS</i>	<i>WHERE</i>	<i>HOW, WHEN, RESULT</i>	<i>CONTROLS</i>
CHEMICAL	Potential contact with contaminated items and resulting water from decontamination procedures.	Sites.	Inadvertent exposure to contaminated items and water resulting from decontamination procedures could lead to adverse health effects.	Personnel will practice proper personal hygiene – wash hands prior to eating/drinking and when leaving the site. Employees will follow decontamination procedures as described above. Employees will wear nitrile gloves and safety glasses when handling contaminated items.
NOISE	Not applicable.			
ELECTRICAL	Not applicable.			
BODY MECHANICS	Not applicable.			
GRAVITY	Slips and falls.	Areas designated for decontamination procedures.	Slips and falls could occur while performing decontamination procedures due to slippery surfaces resulting in bruises, scrapes, or broken bones.	Workers will wear work boots with good traction and ankle support. Keep work area as dry as possible. Wear muck boots as necessary.
WEATHER	Cold/heat stress. Hypothermia/frost bite.	Sites. Sites where air temperature is 35.6°F (2°C) or	Exposure to cold climates may result in cold burns, frostbites, and hypothermia. Exposure to high temperatures may result in heat cramps, heat exhaustion, or heat stroke. Workers whose clothing becomes wet	Training on signs and symptoms of cold/heat stress is required. Personnel will wear appropriate clothing when working outdoors. Employees will remain hydrated and will have sufficient caloric intakes during the day. Employees will change clothing, if it becomes wet.



**SOP-DE-01;
PERSONAL DECONTAMINATION
PROCEDURES**

DATE ISSUED:
12/03/2014
REVISION: 0
PAGE 4 of 6

HSSE CONSIDERATIONS

This section to be completed with concurrence from the Safety and Health Manager.

	Lightning.	less. Outdoor sites.	during decontamination procedures may be exposed to hypothermia and/or frostbite. Electrocution, injury, death, or equipment damage could be caused by lightning strike.	Employees will follow the 30/30 rule during lightning storms.
RADIATION	Ultraviolet (UV) radiation.	Outdoors.	Employees could be exposed to UV radiation during summer months causing sun burns, skin damage, and eye damage.	Employees will wear safety glasses with tinted lenses, long-sleeve work shirts, and long pants. Employees should wear sunscreen, if necessary.
BIOLOGICAL	Plants, insects, and animals.	Sites.	Exposure to plants, insects, and/or animals may cause rashes, blisters, redness, and swelling.	Training on the signs and symptoms of exposure to plants, insects, and animals is required. Avoid contact with plants, insects, and animals. First-aid kits will be available on site. Employees with allergies will notify their supervisor.
MECHANICAL	Not applicable.			
PRESSURE	Not applicable.			
THERMAL	Not applicable.			
HUMAN FACTORS	Inexperienced and improperly trained worker.	Sites.	Inexperienced workers and improper training could cause incidents resulting in adverse health	Employees will be properly trained in this procedure and other applicable procedures. Employees will implement stop work procedures, if necessary.



**SOP-DE-01;
PERSONAL DECONTAMINATION
PROCEDURES**

DATE ISSUED:
12/03/2014
REVISION: 0
PAGE 5 of 6

HSSE CONSIDERATIONS

This section to be completed with concurrence from the Safety and Health Manager.

			effects and/or property damage.	
SIMOPS	Not applicable.			

ADDITIONAL HSSE CONSIDERATIONS

This section to be completed with concurrence from the Safety and Health Manager.

REQUIRED PPE	Safety glasses, high-visibility work shirt or vest, long pants, work boots, and nitrile gloves.
APPLICABLE SDS	Safety Data Sheets (SDSs) will be maintained based on site characterization and contaminants.
REQUIRED PERMITS/FORMS	Per site/project requirements.
ADDITIONAL TRAINING	Per site/project requirements.

DRAWINGS, DOCUMENTS, AND TOOLS/EQUIPMENT

The following documents should be referenced to assist in completing the associated task.

P&IDS	
DRAWINGS	
RELATED SOPs/PROCEDURES/ WORK PLANS	
TOOLS	In general, the following items will be needed: soap, tap water, tarps, decontamination tubs, brushes, and sprayers. The Sampling and Analysis Plan (SAP) or Quality Assurance Project Plan (QAPP) will describe additional items needed for decontamination.
FORMS/CHECKLIST	





**SOP-DE-01;
PERSONAL DECONTAMINATION
PROCEDURES**

DATE ISSUED:
12/03/2014
REVISION: 0
PAGE 6 of 6

APPROVALS/CONCURRENCE

By signing this document, all parties acknowledge the completeness and applicability of this SOP for its intended purpose. Also, by signing this document, it serves as acknowledgement that I have received training on the procedure and associated competency testing.

SOP TECHNICAL AUTHOR	DATE
 Julie Flammang	12/03/2014
SAFETY AND HEALTH MANAGER	DATE
 Tara Schleeman	12/03/2014

Revisions:

Revision	Description	Date



PURPOSE	To provide standard instructions for equipment decontamination.
SCOPE	Pioneer Technical Services, Inc. (Pioneer) prepared this practice for the workforce and this Standard Operating Procedure (SOP) applies to all work performed by and on behalf of Pioneer. All members of the Pioneer workforce who conduct the work shall be trained and competent (as defined by OSHA) in the risk-assessed procedure described below before performing the work.
NOTES	<p>All equipment leaving the contaminated area of a site must be decontaminated. Decontamination methods include removal of contaminants through physical, chemical, or a combination of both methods. Decontamination procedures are to be performed at the same level of protection used in the contaminated area of a site. In some cases, decontamination personnel may be sufficiently protected by wearing one level lower protection. The information for site-specific equipment decontamination and personnel protection levels, as detailed in the Sampling and Analysis Plan (SAP), work plan (WP), and Site-Specific Health and Safety Plan (SSHASP), should be followed.</p> <p>The following decontamination procedures are for typical uncontrolled hazardous waste sites. For a specific or unusual contaminant, such as dioxins, see the SSHASP and consult with the Safety and Health Manager. Decontamination procedures should be used in conjunction with methods to prevent contamination of sampling and monitoring equipment. If practical, particularly with organic contaminants, one-time-use equipment should be used and disposed of in accordance with the SAP, WP, and SSHASP.</p> <p>This SOP covers all equipment decontamination EXCEPT for submersible pumps. Decontamination of pumps is detailed in SOP-DE-02A – Equipment Decontamination - Pumps for Well Sampling.</p>
<p>WORK INSTRUCTIONS</p> <p>The following instructions provide guidance to perform the task in a safe, accurate, and reliable manner. If these instructions present information that is inaccurate or unsafe, personnel must notify the Project Manager, Safety Manager, and the SOP Technical Author to initiate appropriate revisions. Personnel will perform all work under this SOP in a manner that is consistent with procedures and policies described in the appropriate Operation, Maintenance, and Monitoring (O&M) Plan (where applicable), appropriate Site-Specific Health and Safety Plans (SSHASP), and Pioneer Corporate Health and Safety Plan (HASP).</p>	
TASK	INSTRUCTIONS
<p>1. Set up decontamination station.</p>	<p>a. Review the SAP or WP and determine if decontamination fluids need to be contained and the need for special decontamination requirements (i.e., chemical rinse).</p> <p>b. If the fluids require containment, set up the decontamination station so that it is located within a small plastic swimming pool or on plastic sheeting with turned up edges to contain water that may slop over during the decontamination process.</p>



	<p>c. If pressurized or gravity flow water is available, attach a hose or piping to reach the decontamination area. If no water is available, bring 5-gallon containers of tap and deionized water (DI) to the decontamination area to clean the equipment.</p> <p>d. Label empty 5-gallon buckets: <i>gross wash</i>, <i>soap wash</i>, <i>DI rinse</i>, <i>final rinse</i>, and <i>chemical rinse</i> (if required).</p> <p>e. Lay out clean plastic or foil to place cleaned equipment on to allow for air drying.</p> <p>f. If a chemical rinse is required, fill a spray bottle with the appropriate chemical and label the spray bottle with the chemical's name.</p> <p>g. Pour approximately 2.5 to 3 gallons of tap water into the buckets labeled: <i>gross wash</i> and <i>soap wash</i>.</p> <p>h. Add a few drops (1-3 drops) of Liquinox[®] soap to the bucket marked <i>soap wash</i>.</p> <p>i. Pour 2.5-3 gallons of DI water into the buckets labeled: <i>DI rinse</i> and <i>final rinse</i>. If a chemical rinse is required, pour DI water into the bucket labeled: <i>chemical rinse</i>.</p>
<p>2. Remove gross contamination.</p>	<p>Remove gross contamination using pressurized or gravity flow tap water, if available. If not, manually scrub the equipment using the 5-gallon bucket of water marked <i>gross wash</i> and a stiff brush (dedicated to the gross wash step).</p>
<p>3. Wash equipment.</p>	<p>Move the equipment to the 5-gallon bucket marked <i>soap wash</i>. Wash equipment with a stiff brush (dedicated to the soap wash step).</p>
<p>4. Triple rinse equipment.</p>	<p>In the bucket marked <i>DI rinse</i>, triple rinse the equipment with DI water to remove any soap residue.</p>
<p>5. Second rinse with deionized water.</p>	<p>Using DI water, triple rinse the equipment again in the bucket marked <i>final rinse</i> if a chemical rinse is not required.</p>
<p>6. Rinse equipment with chemicals.</p>	<p>In many cases, the tap water and DI water rinses will be sufficient. However, if specified in the SAP, WP, or SSHASP, chemical rinses of the equipment may be required. For inorganic contaminants, a mixture of 10:1 nitric acid in distilled water (10 parts water to 1 part nitric acid) may be specified. A methanol rinse may be required for some organic contaminants, such as hydrocarbons.</p> <p>Spray bottles, clearly marked with the appropriate chemical name, are an acceptable means of rinsing most equipment. To perform the chemical rinse:</p> <ol style="list-style-type: none"> Hold the equipment over a collection container (5-gallon bucket or bowl). Make sure that all personnel and vehicles are upwind of the spray. Spray the piece of equipment inside and out starting at the top and working down to the bottom. Dispose of the contained chemicals as described in the SAP, WP or SSHASP. The Safety and Health Manager and/or Project Manager must approve the disposal method used.



7. Rinse equipment with deionized water.	<p>After a required chemical rinse, rinse the equipment again with the DI water in the bucket marked <i>chemical rinse</i>. This DI water will need to be retained (i.e., do not dispose of this water on the site), tested, and disposed of according to federal and state requirements for the chemical used. The Safety and Health Manager and/or Project Manager must approve the disposal method used.</p> <p>After the rinse in the <i>chemical rinse</i> bucket, triple rinse the equipment again in the bucket marked <i>final rinse</i>.</p>
8. Air dry equipment.	<p>Place equipment on plastic sheeting or foil to air dry.</p>
9. Transport/ store equipment.	<p>Wrap equipment in foil or plastic wrap to transport or store.</p>
10. Clean decontamination equipment.	<ul style="list-style-type: none">a. Triple rinse equipment from the <i>gross wash</i> and <i>soap wash</i> (brushes and buckets) with clean tap water, preferably with pressurized water. Soap can be used on particularly dirty equipment.b. Triple rinse all decontamination equipment with DI water, including <i>DI rinse</i> and <i>final rinse</i> buckets.c. Store decontamination equipment, labeled and in a clean location so they are used only for decontamination purposes.
11. Dispose of decontamination solutions.	<p>Storage of contained decontamination fluids as required by the SAP, QAPP, or WP or of residue from a chemical rinse should have been arranged on site prior to sampling. Once the sampling and associated decontamination is complete, sampling of the stored fluids for hazardous waste criteria will be required. If the fluids are determined to be hazardous (e.g., meet the characteristics of a hazardous waste [ignitability, corrosivity, reactivity, or toxicity] or contain listed wastes from title 40 of the Code of Federal Regulations [CFR] in part 261.4), dispose of them according to federal and state requirements. The Safety and Health Manager and/or Project Manager must approve the disposal method used.</p> <p><u>Note:</u> when using other than the above-mentioned solutions, check with the Safety and Health Manager and the Project Manager.</p>
12. Measure effectiveness of procedures.	<p>Measure the effectiveness of the decontamination procedures using field equipment rinsate blanks as discussed in the SAP, QAPP, or WP.</p>



HEALTH SAFETY SECURITY ENVIRONMENT (HSSE) CONSIDERATIONS

This section to be completed with concurrence from the Safety and Health Manager.

<i>SOURCE</i>	<i>HAZARDS</i>	<i>WHERE</i>	<i>HOW, WHEN, RESULT</i>	<i>CONTROLS</i>
CHEMICAL	Potential contact with contaminated items and resulting water from decontamination procedures.	Sites.	Inadvertent exposure to contaminated items and water resulting from decontamination procedures could lead to adverse health effects.	Personnel will practice proper personal hygiene (wash hands prior to eating/drinking and when leaving the site); follow decontamination procedures as described above; and wear nitrile gloves and safety glasses when handling contaminated items.
	Chemical rinse (e.g., dilute nitric acid, methanol, and hexane).	Sites.	Personnel could be exposed to chemicals via ingestion and skin/eye contact when decontaminating equipment. Exposure could cause irritation of skin/eye and adverse health effects.	<p>Personnel will check and follow safety procedures as outlined in the chemical-specific Safety Data Sheets. Personnel will prevent skin/eye contact with chemicals and they will wear nitrile gloves and eye protection when handling chemicals. Personnel will practice proper personal hygiene (wash hands prior to eating/drinking, after decontaminating equipment, and when leaving the site).</p> <p>All personnel and vehicles will stand upwind when spraying equipment with chemicals. Refer to the Chemical Flushing Guidelines available inside any Pioneer vehicle's first aid kit for first-aid procedures in case of contact with chemicals.</p>
NOISE	Not applicable.			
ELECTRICAL	Not applicable.			



HEALTH SAFETY SECURITY ENVIRONMENT (HSSE) CONSIDERATIONS

This section to be completed with concurrence from the Safety and Health Manager.

<i>SOURCE</i>	<i>HAZARDS</i>	<i>WHERE</i>	<i>HOW, WHEN, RESULT</i>	<i>CONTROLS</i>
BODY MECHANICS	Improper lifting.	Sites.	Back injuries and muscle/back strains could result when using improper techniques to lift and carry 5-gallon containers.	Personnel will use proper lifting techniques: get a good grip, keep the load close to the body, lift with legs and not with back, and avoid lifting loads above shoulder's height. Two people will lift awkward/heavy tools and equipment.
GRAVITY	Falls from slips and trips.	Areas designated for decontamination procedures.	Slips and falls could occur while performing decontamination procedures due to slippery surfaces resulting in bruises, scrapes, or broken bones.	Personnel will wear work boots with good traction and ankle support. Personnel will also be aware of working/walking surfaces and choose a path to avoid hazards, keep work areas as dry as possible, and wear muck boots as necessary.
WEATHER	Cold/heat stress. Hypothermia/frostbite.	Sites. Sites where air temperature is 35.6 °F (2 °C) or less.	Exposure to cold climates may result in cold burns, frostbites, and hypothermia. Exposure to high temperatures may result in heat cramps, heat exhaustion, or heat stroke. Personnel whose clothing becomes wet during decontamination procedures may be exposed to hypothermia and/or frostbite.	Training on signs and symptoms of cold/heat stress is required. Personnel will wear appropriate clothing when working outdoors, remain hydrated, and have sufficient caloric intakes during the day. Personnel will also follow procedures outlined in applicable SSHASP and/or Pioneer corporate HASP. Personnel will change clothing if it becomes wet.



HEALTH SAFETY SECURITY ENVIRONMENT (HSSE) CONSIDERATIONS

This section to be completed with concurrence from the Safety and Health Manager.

<i>SOURCE</i>	<i>HAZARDS</i>	<i>WHERE</i>	<i>HOW, WHEN, RESULT</i>	<i>CONTROLS</i>
	Lightning.	Outdoor sites.	Electrocution, injury, death, or equipment damage could be caused by lightning strike.	Personnel will follow the 30/30 rule during lightning storms.
RADIATION	Ultraviolet (UV) radiation.	Outdoors.	Personnel could be exposed to UV radiation during summer months causing sun burns, skin damage, and eye damage.	Personnel will wear safety glasses with tinted lenses, long-sleeve work shirts, and long pants. Personnel should wear sunscreen, if necessary.
BIOLOGICAL	Plants, insects, and animals.	Sites.	Exposure to plants, insects, and/or animals may cause rashes, blisters, redness, and swelling.	Training on the signs and symptoms of exposure to plants, insects, and animals is required. Personnel will avoid contact with plants, insects, and animals. First-aid kits will be available on the site. Personnel with allergies will notify their supervisor.
MECHANICAL	Not applicable.			
PRESSURE	Not applicable.			
THERMAL	Contact with hot surfaces.	Foil and decontamination equipment.	If foil and decontamination equipment are placed directly in the sun, they could get hot. Contact with hot surfaces could result in personal injury.	Personnel will not set decontamination stations directly in the sun.



HEALTH SAFETY SECURITY ENVIRONMENT (HSSE) CONSIDERATIONS

This section to be completed with concurrence from the Safety and Health Manager.

<i>SOURCE</i>	<i>HAZARDS</i>	<i>WHERE</i>	<i>HOW, WHEN, RESULT</i>	<i>CONTROLS</i>
HUMAN FACTORS	Inexperienced and improperly trained personnel.	Sites.	Inexperienced personnel and improper training could cause incidents resulting in injuries and/or property damage.	Personnel will be properly trained in this procedure and other applicable procedures. Personnel will implement stop work procedures, if necessary.
SIMOPS (Simultaneous Operations)	Not applicable.			

ADDITIONAL HSSE CONSIDERATIONS

This section to be completed with concurrence from the Safety and Health Manager.

REQUIRED PPE	Personnel Protection Equipment (PPE): Safety glasses, high-visibility work shirt or vest, long pants, work boots, and nitrile gloves.
APPLICABLE SDSs	Safety Data Sheets (SDSs) for corresponding chemicals used during chemical rinse will be maintained based on the site characterization and contaminants. Safety Data Sheets are available to Pioneer personnel at the link below: https://pioneertechnicalservices.sharepoint.com/Safety/SafetyDataSheets
REQUIRED PERMITS/ FORMS	Per site/project requirements.
ADDITIONAL TRAINING	Per site/project requirements.

DRAWINGS, DOCUMENTS, AND TOOLS/EQUIPMENT

The following documents should be referenced to assist in completing the associated task.

DRAWINGS	
RELATED SOPs/ PROCEDURES/ WORK PLANS	



TOOLS/ EQUIPMENT	Five empty 5-gallon buckets, tap water, stiff brushes, Liquinox soap, four 5-gallon containers of DI (or distilled water if DI water is not available), chemicals for chemical rinse (if required), small plastic swimming pool/plastic sheeting or foil, tarps, and sprayers (if available). If additional items for decontamination are needed, they will be listed on the SAP.
FORMS/ CHECKLIST	

APPROVALS/CONCURRENCE	
By signing this document, all parties acknowledge the completeness and applicability of this SOP for its intended purpose. Also, by signing this document, it serves as acknowledgement that I have received training on the procedure and associated competency testing.	
SOP TECHNICAL AUTHOR	DATE
 Julie Flammang	09/08/2020
SAFETY AND HEALTH MANAGER	DATE
 Tara Schleeman	09/08/2020



**SOP-DE-02A;
EQUIPMENT DECONTAMINATION –
PUMPS FOR WELL SAMPLING**

DATE ISSUED:
05/22/2015
REVISION: 0
PAGE 1 of 11

PURPOSE	To provide standard instructions for equipment decontamination to pumps for well sampling.
SCOPE	This practice has been prepared for the Pioneer Technical Services, Inc. (Pioneer) workforce and applies to work carried out by and on behalf of Pioneer. All members of the Pioneer workforce who conduct the work shall be trained and competent in the risk-assessed work described below.

WORK INSTRUCTIONS

The following instructions are intended to provide sufficient guidance to perform the task in a safe, accurate, and reliable manner. Should these instructions present information that is inaccurate or unsafe, operations personnel must bring the issue to the attention of the Project Manager and the appropriate revisions made. All work carried under this SOP will be consistent with procedures and policies described in the appropriate Operation, Maintenance, and Monitoring (O&M) Plan (where applicable), appropriate Site-Specific Health and Safety Plan (SSHASP), and Pioneer Corporate Health and Safety Plan (HASP).

TASK	INSTRUCTIONS
Notes	<p>All non-disposable or non-dedicated equipment used for sampling or monitoring activities must be decontaminated prior to leaving a site. Decontamination methods include removal of contaminants through physical methods, chemical cleaning or a combination of both methods. Decontamination of equipment should be performed in the same level of protection as worn during sampling. In some cases, personnel may be sufficiently protected during decontamination activities by wearing one level lower of PPE. Requirements for site specific equipment decontamination and personnel protection levels as detailed in the sampling and analysis plan (SAP), work plan (WP) or Site-Specific Health and Safety Plan (HASP) should be followed.</p> <p>The following decontamination procedures are for typical uncontrolled hazardous waste sites. For a specific or unusual contaminant such as dioxins, the decontamination procedures should be discussed in the SAP, WP and or HASP. Decontamination procedures should be used in conjunction with storage methods that prevent contamination of cleaned sampling and monitoring equipment.</p> <p>One time use equipment is preferred if practical, and should be disposed of in accordance with the site-specific HASP, SAP or WP. Dedicated equipment should be used, when practical for long term sampling at a location.</p> <p>Prior to the sampling event review the HASP and SAP to determine if purge and decontamination water needs to be contained and and/or proper disposal and storage requirements. When preparing a SAP/HASP determine if water from all stages of the decontamination procedure needs to be contained or if only water from initial stages of the process requires containment. As part of the planning process in determining a method for storage and disposal of purge and decontamination fluids, the amount of water that could be generated during the sampling event, and the type and concentrations of potential contaminants should be estimated. If needed the proper equipment for either storage or disposal should be available on-site at the start of sampling. Water can be contained at the sampling location or on site in</p>



	tanks, barrels or buckets for later disposal. Purge and decontamination water stored on the site can be sampled and analyzed so that the proper disposal method can be determined. Waste water could also be removed at the time of sampling with a pump truck to a disposal site.
--	--

Decontamination Procedures for Inorganic Contaminants

<p>1. Decontamination procedures for inorganic contaminants.</p>	<ol style="list-style-type: none"> 1. Set up the decontamination station. If water needs to be contained, place a sheet of plastic on the ground or a small swimming pool in the decontamination area. Wrap the edges of the plastic sheeting around pieces of PVC or boards to form a small pool to prevent any spilled water from running onto adjacent ground. All decontamination activities should take place within this confined area. If containment of decontamination fluids is required, set up a means of collecting the water (bucket, hose, barrel, etc.) 2. Remove pump from the well making sure that tubing and pump do not contact the ground surface. If disposable or dedicated tubing is being used, remove tubing from the pump and place in appropriate storage/refuse container. Don a new pair of gloves and if needed add a small piece of tubing to pump. 3. Place pump in decontamination container containing tap water. The size of the pump and amount of tubing needing decontamination will determine the size of the container. The container can range from a stainless steel pan which holds 1 -2 gallons for the smaller 12 volt submersible pumps with a small amount of tubing to a 5 gallon bucket or similar large container that will hold the larger pumps such as the Grunfoss Redi-Flo II and larger 12 volt submersible pumps . The pump should be placed in a container that is tall enough to submerge the pump, and is easy to pour additional fluid into. Non-dedicated tubing such as that on the Grunfoss Redi-Flo II will be decontaminated on the reel or for smaller amounts of reusable tubing typically found on the 12 volt submersible pumps, the tubing and electric cord will be coiled as it is removed from the well and placed in a bucket dedicated to decontamination. 4. If not done previously, don a new pair of nitrile gloves. 5. Pour tap water into the container to cover the pump. Turn the pump on and continue pouring tap water into the container until all water from the well has been flushed from the pump and tubing. The amount will depend on the amount of tubing associated with the pump and can range from 1 gallon for the smaller pumps to 5 gallons for the Grunfoss pumps. If the water purged from the well was turbid or colored, the water flowing from the pump discharge can be monitored to determine when the well water has been removed. If the water is to be contained, make sure it is discharged throughout the decontamination process into the appropriate container. 6. Add a very small pinch or drop of non-phosphate soap (use Liquinox[®] or Alconox[®]) to the container and turn on pump. Continue pouring tap water into the container to flush the pump until the soapy water has been pumped through the entire length of tubing.
--	---



**SOP-DE-02A;
EQUIPMENT DECONTAMINATION –
PUMPS FOR WELL SAMPLING**

DATE ISSUED:
05/22/2015
REVISION: 0
PAGE 3 of 11

	<p>7. Turn the pump off and place it in a second container for a de-ionized (DI) water flush of the soapy water. Pour DI water into the container to cover the pump. Turn the pump on and continue pouring DI water into the container until the soapy water has been flushed from the system. This water should be discharged over any tubing that will be reinserted into the next well. Keep in mind that this process is to remove contaminants from the pump and tubing so that they are not introduced to the next well. Make sure that the tubing is thoroughly rinsed. Water purged from the next well will flush remaining DI water from the tubing.</p> <p>8. Turn the pump off, empty water from the bucket containing tubing if necessary and place pump and tubing into a bucket dedicated for pump storage. The Grunfoss Redi-Flow II pump should be returned to the pump holder on the reel, remember to rinse the pump holder with DI water between wells. Care should be taken to keep tubing and pumps from touching the ground or other surface during transport and storage. A plastic bag can be placed over the container holding the pump or a dedicated plastic container can be used to transport or store the pump.</p> <p>9. If containment is required, empty the water remaining in the decontamination containers into the storage/disposal container. Cover the dedicated decontamination containers with plastic, foil or a lid to prevent contaminants from entering the containers during transport or storage. Empty the water in the swimming pool or plastic into the storage container by scooping the water into the disposal container. If needed a funnel dedicated to the project can be used to help in getting water into the container.</p>
--	--

Decontamination Procedures for Organic Contaminants

<p>1. Decontamination procedures for organic contaminants.</p>	<p>It is strongly recommended that disposable or dedicated tubing be used for all organic contaminant sampling.</p> <p>If a submersible pump is required for sampling, a stainless steel pump that can be taken apart for cleaning is recommended.</p> <p>If free product is detected in a well, use disposable tubing or a bailer to collect the sample as purging large amounts of product through tubing makes it almost impossible to clean.</p> <p>1. Set up the decontamination station. If water needs to be contained, place a sheet of plastic on the ground or a small swimming pool in the decontamination area. Wrap the edges of the plastic sheeting around pieces of PVC or boards to form a small pool to prevent any spilled water from running onto adjacent ground. All decontamination activities should take place within this confined area. If containment of decontamination fluids is required, set up a means of collecting the water (bucket, hose, barrel, etc.).</p> <p>2. Remove pump from the well making sure that tubing and pump do not contact the ground surface. If disposable or dedicated tubing is being used, remove</p>
--	--



**SOP-DE-02A;
EQUIPMENT DECONTAMINATION –
PUMPS FOR WELL SAMPLING**

**DATE ISSUED:
05/22/2015
REVISION: 0
PAGE 4 of 11**

tubing from pump and place in appropriate storage/refuse container. Don a new pair of nitrile gloves. Wipe pump with a paper towel wetted with DI or methanol (or solvent specified in the SAP/WP/HASP). Add a small piece of tubing to pump. If tubing is to be reused, wet a paper towel with a small amount of DI or methanol (or other solvent specified in the SAP) and wipe pump and tubing as it is removed from the well.

3. Place pump in decontamination container containing tap water. The size of the pump and amount of tubing needing decontamination will determine the size of the container. The container can range from a stainless steel pan which holds 1 -2 gallons for the smaller 12 volt submersible pumps with a small amount of tubing to a 5 gallon bucket or similar large container that will hold the larger pumps such as the Grunfoss Redi-Flo II and the larger 12 volt submersible pumps. The pump should be placed in a container that is tall enough to submerge the pump, and is easy to pour additional fluid into. Non-dedicated tubing such as that on the Grunfoss Redi-Flo II will be decontaminated on the reel or for smaller amounts of reusable tubing on the 12 volt submersible pumps, the tubing and electric cord will be coiled as it is removed from the well and placed in a bucket dedicated to decontamination.
4. If not done previously, don a new pair of nitrile gloves.
5. Pour tap water into the container to cover the pump. Turn the pump on and continue pouring tap water into the container until all water from the well has been flushed from the pump and tubing. The amount will depend on the amount of tubing associated with the pump and can range from 1 gallon for the smaller pumps to 5 gallons for the Grunfoss pumps. If the water purged from the well was turbid or colored, the water flushing from the pump discharge can be monitored to determine when the well water has been removed. If the water is to be contained make sure it is discharged throughout the decontamination process into the appropriate container.
6. Add a **very** small pinch or drop of non-phosphate soap (use Liquinox[®] or Alconox[®]) to the container and turn on pump. Continue pouring tap water into the container to flush the pump until the soapy water has at least been pumped through the entire length of tubing.
7. At this time a small amount of methanol or solvent can be run through the pump, depending on the expected contaminants. Turn off the pump and place it into a container holding the appropriate solvent. Turn the pump on and run the solvent through the pump. Make sure that a container is available to catch and retain the used solvent. Turn the pump off.
8. If using a stainless steel pump that can be taken apart, follow the manufacturer's directions, disassemble the pump, wipe all parts of the pump with methanol, DI or other solvent and reassemble.
9. Place the pump in a container for a de-ionized (DI) water flush of the pump and tubing. Pour DI water into the container to cover the pump. Turn the pump on



**SOP-DE-02A;
EQUIPMENT DECONTAMINATION –
PUMPS FOR WELL SAMPLING**

DATE ISSUED:
05/22/2015
REVISION: 0
PAGE 5 of 11

	<p>and continue pouring DI water into the container until the solvent (methanol) has been flushed from the system. This water should be discharged over any tubing that will be reinserted into the next well. Keep in mind that this process is to remove contaminants from the pump and tubing so that they are not introduced to the next well. Make sure that the tubing is thoroughly rinsed. Water from the next well will be run through the tubing prior to sampling, any DI water remaining will be flushed from the pump during the purging.</p> <p>10. Turn the pump off, empty water from the bucket containing tubing if necessary and place pump and tubing into a bucket dedicated for pump storage. The Grunfoss Redi-Flow II pump should be returned to the pump holder on the reel, remember to rinse the pump holder with DI water between wells. Care should be taken to keep tubing and pumps from touching the ground or other surface during transport and storage. A plastic bag can be placed over the container holding the pump or a dedicated plastic container can be used to transport or store the pump.</p> <p>11. If containment is required empty the water remaining in the decontamination containers into the storage/disposal container. Cover the dedicated decontamination containers with plastic, foil or a lid to prevent contaminants from entering the containers during transport or storage. Empty the water in the swimming pool or plastic into the storage container by scooping the water into the disposal container. If needed a funnel dedicated to the project can be used to help in getting water into the container</p>
Equipment Used for Decontamination	
1. Equipment used for decontamination.	<p>1. Rinse equipment used in the decontamination process with tap water, preferably pressurized. Do not rinse the container labeled DI!</p> <p>2. Keep decontamination equipment separated so that it is only used for decontamination. Make sure it is labeled appropriately.</p>
Disposal of Decontamination Solutions	
1. Disposal of decontamination solutions.	<p>1. Dispose of the soap/tap water solution and the de-ionized water rinse as detailed in the SAP/WP or site specific HASP.</p> <p>2. Dispose of the solvent rinse residue into proper waste containers. Be sure to check with the health and safety officer and the project manager for disposal requirements. For example, some solvents can be evaporated.</p>
Effectiveness of Decontamination	
1. Effectiveness of decontamination.	1. Effectiveness of the decontamination procedures will be measured using field equipment rinsate blanks (see the site-specific Quality Assurance Project Plan and SOP-SA-03B Preparation of Equipment Rinsate Blanks for Submersible Pumps).



**SOP-DE-02A;
EQUIPMENT DECONTAMINATION –
PUMPS FOR WELL SAMPLING**

**DATE ISSUED:
05/22/2015
REVISION: 0
PAGE 6 of 11**

HSSE CONSIDERATIONS

This section to be completed with concurrence from the Safety and Health Manager.

<i>SOURCE</i>	<i>HAZARDS</i>	<i>WHERE</i>	<i>HOW, WHEN, RESULT</i>	<i>CONTROLS</i>
CHEMICAL	Potential contact with contaminated items and resulting water from decontamination procedures.	Sites.	Inadvertent exposure to contaminated items and water resulting from decontamination procedures could lead to adverse health effects.	Personnel will practice proper personal hygiene – wash hands prior to eating/drinking, after decontamination procedures, and when leaving the site. Employees will follow decontamination procedures as described above. Employees will wear nitrile gloves and safety glasses when handling contaminated items and decontaminating equipment.
	Methanol.	Sites.	Employees could be exposed to methanol via skin/eye contact and ingestion/ inhalation when decontaminating equipment. Exposure could cause irritation of skin/eye. Adverse health effects can also result if methanol is ingested and/or inhaled. Direct contact with methanol during winter months can result in skin discomfort due to rapid evaporative cooling.	Employees will prevent skin/eye contact with methanol and they will wear nitrile gloves and safety glasses when handling methanol. Employees will use methanol in well-ventilated areas. Employees will practice proper personal hygiene – wash hands prior to eating/drinking, after decontamination procedures, and when leaving the site. During winter months, personnel will wear a pair of liner gloves underneath nitrile gloves.
	Liquinox [®] / Alconox [®]	Sites.	Employees could be exposed to Liquinox [®] / Alconox [®] via ingestion and	Employees will wear nitrile gloves and safety glasses during equipment decontamination.



**SOP-DE-02A;
EQUIPMENT DECONTAMINATION –
PUMPS FOR WELL SAMPLING**

**DATE ISSUED:
05/22/2015
REVISION: 0
PAGE 7 of 11**

HSSE CONSIDERATIONS

This section to be completed with concurrence from the Safety and Health Manager.

			skin/eye contact during equipment decontamination resulting in adverse health effects.	
NOISE	Not applicable.			
ELECTRICAL	Not applicable.			
BODY MECHANICS	Improper lifting.	Sites.	Back injuries and muscle/back strains could result when using improper techniques to lift and carry containers, decontamination solutions, and tools/equipment.	Personnel will use proper lifting techniques – get a good grip, keep the load close to the body, lift with legs and not with back, and avoid lifting loads above shoulder’s height. Two people will lift awkward/heavy tools/equipment, if necessary.
GRAVITY	Falls from slips and trips.	Areas designated for decontamination procedures.	Slips and falls could occur while performing decontamination procedures due to slippery surfaces resulting in bruises, scrapes, or broken bones.	Workers will wear work boots with good traction and ankle support. Personnel will be aware of working/walking surfaces and choose a path to avoid hazards. Keep work areas as dry as possible. Wear muck boots, as necessary.
	Dropping decontamination solution containers.	Work truck and decontamination site.	Decontamination solution containers could fall and strike worker while carrying them and pouring solution.	Workers will wear steel-toed boots and be cautious when carrying/moving containers.
WEATHER	Cold/heat stress.	Sites.	Exposure to cold climates may result in cold burns, frostbites,	Training on signs and symptoms of cold/heat stress is required. Personnel will wear appropriate clothing when



**SOP-DE-02A;
EQUIPMENT DECONTAMINATION –
PUMPS FOR WELL SAMPLING**

DATE ISSUED:
05/22/2015
REVISION: 0
PAGE 8 of 11

HSSE CONSIDERATIONS

This section to be completed with concurrence from the Safety and Health Manager.

	Hypothermia/frost bite.	Sites where air temperature is 35.6°F (2°C) or less.	and hypothermia. Exposure to high temperatures may result in heat cramps, heat exhaustion, or heat stroke. Workers whose clothing becomes wet during decontamination procedures may be exposed to hypothermia and/or frostbite.	working outdoors. Employees will remain hydrated and will have sufficient caloric intakes during the day. Personnel will follow procedures outlined in applicable SSHASP and/or Pioneer corporate HASP. Employees will change clothing, if it becomes wet.
	Lightning.	Outdoor sites.	Electrocution, injury, death, or equipment damage could be caused by lightning strike.	Employees will follow the 30/30 rule during lightning storms.
RADIATION	Ultraviolet (UV) radiation.	Outdoors.	Employees could be exposed to UV radiation during summer months causing sun burns, skin damage, and eye damage.	Employees will wear safety glasses with tinted lenses, long-sleeve work shirts, and long pants. Employees should wear sunscreen, if necessary.
BIOLOGICAL	Plants, insects, and animals.	Sites.	Exposure to plants, insects, and/or animals may cause rashes, blisters, redness, and swelling.	Training on the signs and symptoms of exposure to plants, insects, and animals is required. Avoid contact with plants, insects, and animals. First-aid kits will be available on site. Employees with allergies will notify their supervisor.



**SOP-DE-02A;
EQUIPMENT DECONTAMINATION –
PUMPS FOR WELL SAMPLING**

DATE ISSUED:
05/22/2015
REVISION: 0
PAGE 9 of 11

HSSE CONSIDERATIONS

This section to be completed with concurrence from the Safety and Health Manager.

MECHANICAL	Pinch points.	Pumps.	Employees could be exposed to hand injuries such as pinched fingers when taking apart pumps for cleaning.	Employees will wear gloves when taking pumps apart for cleaning.
PRESSURE	Not applicable.			
THERMAL	Contact with hot surfaces.	Foil and decontamination equipment.	If foil and decontamination equipment (e.g., stainless steel pans) are placed directly in the sun, they could get hot. Contact with hot surfaces could result in personal injuries.	Personnel will prevent setting decontamination stations directly in the sun.
HUMAN FACTORS	Inexperienced and improperly trained worker.	Sites.	Inexperienced workers and improper training could cause incidents resulting in adverse health effects and/or property damage.	Employees will be properly trained in this procedure and other applicable procedures. Employees will implement stop work procedures, if necessary.
SIMOPS	Not applicable.			

ADDITIONAL HSSE CONSIDERATIONS

This section to be completed with concurrence from the Safety and Health Manager.

REQUIRED PPE	Hard hat, safety glasses, high-visibility work shirt or vest, long pants, work boots, and nitrile gloves. Liner gloves, during winter months.
APPLICABLE SDS	Methanol and Liquinox [®] / Alconox [®] . Safety Data Sheets (SDSs) will be maintained based on site characterization and contaminants.



**SOP-DE-02A;
EQUIPMENT DECONTAMINATION –
PUMPS FOR WELL SAMPLING**

**DATE ISSUED:
05/22/2015
REVISION: 0
PAGE 10 of 11**

HSSE CONSIDERATIONS

This section to be completed with concurrence from the Safety and Health Manager.

REQUIRED PERMITS/FORMS	Per site/project requirements.
ADDITIONAL TRAINING	Per site/project requirements.



DRAWINGS, DOCUMENTS, AND TOOLS/EQUIPMENT

The following documents should be referenced to assist in completing the associated task.

P&IDS	
DRAWINGS	Map with site location and sample locations.
RELATED SOPs/PROCEDURES/WORK PLANS	SOP-SA-03B Preparation of Equipment Rinsate Blanks for Submersible Pumps
TOOLS	Pump, small swimming pool or plastic sheeting and pieces of PVC or boards, tap water, stainless steel pan or 5 gallon bucket/similar large container (to fit pump), Liquinox© or Alconox, DI water, plastic bags. Optional: bucket, hose, barrel, etc. for water containment, funnel, methanol.
FORMS/CHECKLIST	

APPROVALS/CONCURRENCE

By signing this document, all parties acknowledge the completeness and applicability of this SOP for its intended purpose. Also, by signing this document, it serves as acknowledgement that I have received training on the procedure and associated competency testing.

SOP TECHNICAL AUTHOR	DATE
 Julie Flammang	05/22/2015
SAFETY AND HEALTH MANAGER	DATE
 Tara Schleeman	05/22/2015



**SOP-DE-02A;
EQUIPMENT DECONTAMINATION –
PUMPS FOR WELL SAMPLING**

**DATE ISSUED:
05/22/2015
REVISION: 0
PAGE 11 of 11**

APPROVALS/CONCURRENCE

By signing this document, all parties acknowledge the completeness and applicability of this SOP for its intended purpose. Also, by signing this document, it serves as acknowledgement that I have received training on the procedure and associated competency testing.

Revisions:

Revision	Description	Date



**SOP-DE-03;
INVESTIGATION DERIVED WASTE
HANDLING**

DATE ISSUED:
12/03/2014
REVISION: 0
PAGE 1 of 7

PURPOSE	To provide standard instructions for handling investigation-derived waste in accordance with the US Environmental Protection Agency (EPA) protocols and Department of Environmental Quality (DEQ) guidance. Investigation-derived waste may be generated during a Site Assessment (SA), Site Investigation (SI), or Remedial Investigation (RI).
SCOPE	This practice has been prepared for the Pioneer Technical Services, Inc. (Pioneer) workforce and applies to work carried out by and on behalf of Pioneer. All members of the Pioneer workforce who conduct the work shall be trained and competent in the risk-assessed work described below.

WORK INSTRUCTIONS

The following instructions are intended to provide sufficient guidance to perform the task in a safe, accurate, and reliable manner. Should these instructions present information that is inaccurate or unsafe, operations personnel must bring the issue to the attention of the Project Manager and the appropriate revisions made. All work carried under this SOP will be consistent with procedures and policies described in the appropriate Operation, Maintenance, and Monitoring (O&M) Plan (where applicable), appropriate Site-Specific Health and Safety Plan (SSHASP), and Pioneer Corporate Health and Safety Plan (HASP).

TASK	INSTRUCTIONS
1. Collect and dispose of decontamination fluids.	<p>Collect and dispose of decontamination fluids by using one of the following methods:</p> <ul style="list-style-type: none"> - Send fluids to a Treatment, Storage, and Disposal (TSD) facility. - Evaporate fluids. - Tread fluids using an activated carbon or air sparging unit. - Temporarily store fluids until determined if they are contaminated. <p>Dispose of decontamination fluids, generated from cleaning equipment used in background sampling or for sampling in areas where past results indicate that contaminants are below standards, to the ground surface.</p>
2. Discharge groundwater from developing and purging wells.	If past monitoring results and laboratory analysis indicate that all contaminants are below groundwater standards, discharge groundwater generated from developing and purging monitoring wells to the ground surface.
3. Collect/label/store contaminated groundwater from developing and purging wells.	<p>If past monitoring results indicate that one or more contaminants are above groundwater standards, collect the purged water and potentially contaminated water.</p> <p>There may be instances (e.g., inclement weather) where purge water and/or decontamination water will be temporarily stored in drums or tanks to be treated on site with granulated activated carbon or air sparging. If the water is determined by laboratory analysis to contain contaminants above groundwater standards and cannot be treated on site, store the water on site until shipping/disposal arrangements can be made.</p> <p>If the water is visibly contaminated, drum, label, and store the water on site until</p>



**SOP-DE-03;
INVESTIGATION DERIVED WASTE
HANDLING**

DATE ISSUED:
12/03/2014
REVISION: 0
PAGE 2 of 7

	shipping/disposal arrangements are made. Label all containers stored on site with the following information: date, time, contents, any corresponding analytical data, collection location, contact person, and contact agency, etc.
4. Return soils back to borehole.	Unless it is visibly contaminated, place soil and/or cuttings from monitoring well installation back in the borehole.
5. Collect/label/store contaminated soils from installing wells.	<p>If the soil is visibly contaminated, drum, label, and store the soil/cuttings on site until shipping/disposal arrangements are made.</p> <p>Drum and label soils from borings/well installations located in previously sampled areas that are known to be contaminated. Leave these soils on site until shipping/disposal arrangements are made.</p>
6. Pack and dispose of one-time use equipment and PPE.	<p>Pack disposable equipment intended for one-time use and personal protective equipment (PPE) materials for appropriate disposal. Double bag the disposable equipment and PPE utilized for sampling and dispose of it as a solid waste in the local landfill.</p> <p>Package, drum, and label disposable equipment and PPE utilized for sampling visibly contaminated sites or sites known to be contaminated from previous monitoring. Leave equipment and PPE on site until shipping/disposal arrangements are made.</p>
7. Dispose of samples not used for analysis.	<p>Laboratories will dispose of the portions of the samples submitted, but not used for analysis.</p> <p>If samples are retained and not sent for analysis, they need to be returned to the site prior to remediation or disposed of according to federal and state regulations.</p>



**SOP-DE-03;
INVESTIGATION DERIVED WASTE
HANDLING**

DATE ISSUED:
12/03/2014
REVISION: 0
PAGE 3 of 7

HSSE CONSIDERATIONS

This section to be completed with concurrence from the Safety and Health Manager.

<i>SOURCE</i>	<i>HAZARDS</i>	<i>WHERE</i>	<i>HOW, WHEN, RESULT</i>	<i>CONTROLS</i>
CHEMICAL	<p>Potential contact with contaminated soils and resulting water from decontamination procedures.</p> <p>Nitric acid.</p>	<p>Sites.</p> <p>Sites.</p>	<p>Inadvertent exposure to contaminated soils and water resulting from decontamination procedures could lead to adverse health effects.</p> <p>Employees could be exposed to nitric acid via ingestion and skin/eye contact when decontaminating equipment. Exposure could cause irritation of skin/eye and adverse health effects.</p>	<p>Personnel will practice proper personal hygiene – wash hands prior to eating/drinking and when leaving the site. Employees will follow decontamination procedures as described above. Employees will wear nitrile gloves and safety glasses when handling contaminated items.</p> <p>Employees will prevent skin/eye contact with nitric acid and they will wear nitrile gloves and eye protection when handling nitric acid. Employees will practice proper personal hygiene – wash hands prior to eating/drinking, after decontaminating equipment, and when leaving the site. Refer to the Chemical Flushing Guidelines available inside vehicle’s first aid kit for first-aid procedures in case of contact with nitric acid.</p>
NOISE	Not applicable.			
ELECTRICAL	Not applicable.			
BODY MECHANICS	Improper shoveling techniques.	Sites.	Personnel could be injured if using improper shoveling techniques to store contaminated soils/cuttings in drums, causing back injuries and muscle/back strains.	Personnel will use proper shoveling techniques: keep feet wide apart, place front foot close to shovel, put weight on front foot, use leg to push shovel, shift weight to rear foot, keep load close to body, and turn feet in direction of throw.



**SOP-DE-03;
INVESTIGATION DERIVED WASTE
HANDLING**

DATE ISSUED:
12/03/2014
REVISION: 0
PAGE 4 of 7

HSSE CONSIDERATIONS

This section to be completed with concurrence from the Safety and Health Manager.

	Improper lifting.	Sites.	Back injuries and muscle/back strains could result when using improper techniques to lift and carry 5-gallon containers of tap water.	Personnel will use proper lifting techniques – get a good grip, keep the load close to the body, lift with legs and not with back, and avoid lifting loads above shoulder’s height.
GRAVITY	Falls from slips and trips.	Uneven terrain, slick/muddy/wet surfaces and steep slopes.	Walking/working on slick/muddy/wet and uneven terrain could cause slips and trips resulting in falls and injuries.	Workers will wear work boots with good traction and ankle support. Personnel will be aware of working/walking surfaces and choose a path to avoid hazards. Keep work areas as dry as possible. Wear muck boots, as necessary.
WEATHER	Cold/heat stress.	Sites.	Exposure to cold climates may result in cold burns, frostbites, and hypothermia. Exposure to high temperatures may result in heat cramps, heat exhaustion, or heat stroke.	Training on signs and symptoms of cold/heat stress is required. Personnel will wear appropriate clothing when working outdoors. Employees will remain hydrated and will have sufficient caloric intakes during the day. Personnel will follow procedures outlined in applicable SSHASP and/or Pioneer corporate HASP.
	Hypothermia/frost bite.	Sites where air temperature is 35.6°F (2°C) or less.	Workers whose clothing becomes wet during decontamination procedures may be exposed to hypothermia and/or frostbite.	Employees will change clothing, if it becomes wet.
	Lightning.	Outdoor sites.	Electrocution, injury, death, or equipment damage could be	Employees will follow the 30/30 rule during lightning storms.



**SOP-DE-03;
INVESTIGATION DERIVED WASTE
HANDLING**

DATE ISSUED:
12/03/2014
REVISION: 0
PAGE 5 of 7

HSSE CONSIDERATIONS

This section to be completed with concurrence from the Safety and Health Manager.

			caused by lightning strike.	
RADIATION	Ultraviolet (UV) radiation.	Outdoors.	Employees could be exposed to UV radiation during summer months causing sun burns, skin damage, and eye damage.	Employees will wear safety glasses with tinted lenses, long-sleeve work shirts, and long pants. Employees should wear sunscreen, if necessary.
BIOLOGICAL	Plants, insects, and animals.	Sites.	Exposure to plants, insects, and/or animals may cause rashes, blisters, redness, and swelling.	Training on the signs and symptoms of exposure to plants, insects, and animals is required. Avoid contact with plants, insects, and animals. First-aid kits will be available on site. Employees with allergies will notify their supervisor.
MECHANICAL	Not applicable.			
PRESSURE	Not applicable.			
THERMAL	Not applicable.			
HUMAN FACTORS	Inexperienced and improperly trained worker.	Sites.	Inexperienced workers and improper training could cause incidents resulting in adverse health effects and/or property damage.	Employees will be properly trained in this procedure and other applicable procedures. Employees will implement stop work procedures, if necessary.
SIMOPS	Not applicable.			

ADDITIONAL HSSE CONSIDERATIONS

This section to be completed with concurrence from the Safety and Health Manager.

REQUIRED PPE	Hard hat, safety glasses, high-visibility work shirt or vest, long pants, work boots, and nitrile gloves.
---------------------	---



**SOP-DE-03;
INVESTIGATION DERIVED WASTE
HANDLING**

DATE ISSUED:
12/03/2014
REVISION: 0
PAGE 6 of 7

HSSE CONSIDERATIONS

This section to be completed with concurrence from the Safety and Health Manager.

APPLICABLE SDS	Safety Data Sheets (SDSs) will be maintained based on site characterization and contaminants. Nitric acid.
REQUIRED PERMITS/FORMS	Per site/project requirements.
ADDITIONAL TRAINING	Per site/project requirements.

DRAWINGS, DOCUMENTS, AND TOOLS/EQUIPMENT

The following documents should be referenced to assist in completing the associated task.

P&IDS	
DRAWINGS	
RELATED SOPs/PROCEDURES/ WORK PLANS	SOP-DE-02 Equipment Decontamination.
TOOLS	Five 5-gallon buckets, tap water, stiff brushes, soap, de-ionized or distilled water, nitric acid (if required), plastic sheeting or foil, tarps, decontamination tubs and buckets, sprayers, storage containers, labels, and shovels.
FORMS/CHECKLIST	





**SOP-DE-03;
INVESTIGATION DERIVED WASTE
HANDLING**

DATE ISSUED:
12/03/2014
REVISION: 0
PAGE 7 of 7

APPROVALS/CONCURRENCE

By signing this document, all parties acknowledge the completeness and applicability of this SOP for its intended purpose. Also, by signing this document, it serves as acknowledgement that I have received training on the procedure and associated competency testing.

SOP TECHNICAL AUTHOR	DATE
 Julie Flammang	12/03/2014
SAFETY AND HEALTH MANAGER	DATE
 Tara Schleeman	12/03/2014

Revisions:

Revision	Description	Date



**SOP-GW-02;
SAMPLING WITH A BAILER**

DATE ISSUED:
12/03/2014
REVISION: 0
PAGE 1 of 7

PURPOSE	To provide standard instructions for sampling with a bailer.
SCOPE	This practice has been prepared for the Pioneer Technical Services, Inc. (Pioneer) workforce and applies to work carried out by and on behalf of Pioneer. All members of the Pioneer workforce who conduct the work shall be trained and competent in the risk-assessed work described below.
WORK INSTRUCTIONS	
The following instructions are intended to provide sufficient guidance to perform the task in a safe, accurate, and reliable manner. Should these instructions present information that is inaccurate or unsafe, operations personnel must bring the issue to the attention of the Project Manager and the appropriate revisions made. All work carried under this SOP will be consistent with procedures and policies described in the appropriate Operation, Maintenance, and Monitoring (O&M) Plan (where applicable), appropriate Site-Specific Health and Safety Plan (SSHASP), and Pioneer Corporate Health and Safety Plan (HASP).	
TASK	INSTRUCTIONS
1. Determine water level in the well.	Using clean, non-contaminating equipment (e.g., an electronic depth to water level indicator (avoid indicating paste)) (per SOP-DE-02 Equipment Decontamination), determine the water level in the well. Refer to SOP-GW-03 Depth to Water Level Measurements for instructions. If required, check for the presence of free or floating product with an interface probe or clear bailer. Calculate the fluid volume in the casing and determine the appropriate volume of water to be purged prior to any sample collection.
2. Collect sample with bailer.	Attach a clean, decontaminated bailer to clean line for lowering and raising the bailer into the well. A disposable or dedicated bailer is preferred. Make sure the knot will not come loose. Lower bailer slowly until it contacts water surface. The bailer should not contact the bottom of the well. Allow bailer to sink slowly and fill with a minimum of surface disturbance. Slowly raise bailer to surface. Do not allow bailer line to contact the ground surface.
3. Discharge purged water into appropriate container.	Use bottom discharge device to slowly discharge purged water into an appropriate container, or pour slowly from top of bailer. Purged water shall be disposed of in accordance with the site-specific Sampling and Analysis Plan (SAP), client disposal requirements and/or SOP-DE-03 Investigation Derived Waste Handling.
4. Acquire sufficient purge volume.	Repeat task #2 as needed to acquire sufficient purge volume.



**SOP-GW-02;
SAMPLING WITH A BAILER**

DATE ISSUED:
12/03/2014
REVISION: 0
PAGE 2 of 7

5. Pour water into appropriate containers.	Once sufficient purge volume has been collected, use bottom discharge device or pour slowly from top of bailer into appropriate sample containers.
6. Acquire sufficient sample volume.	Repeat task #2 as needed to acquire sufficient sample volume.
7. Preserve and cap the samples.	<p>If water is being collected for volatile organic compounds (VOCs) analysis, place preservative in vials (if appropriate, prior to filling).</p> <p>Check that a Teflon liner is present in cap if one is required. After filling, secure the cap tightly. Check for air bubbles.</p> <p>To check for air bubbles: turn the VOC bottle upside down, tap lightly, turn right side up, see if any bubbles float to the top. If you see a bubble, remove lid, add additional water, and reseal.</p>
8. Label the samples.	Label the sample bottle with an appropriate tag/label. Be sure to complete the tag with necessary information. Record the information in the field logbook and complete all chain-of-custody documents.
9. Transport the samples.	Place the properly labeled sample bottle in an appropriate carrying container maintained at 4°C +/- 2°C throughout the sampling and transportation period.
10. Decontaminate bailer.	Decontaminate bailer thoroughly after each use according to SOP-DE-02 Equipment Decontamination.



**SOP-GW-02;
SAMPLING WITH A BAILER**

DATE ISSUED:
12/03/2014
REVISION: 0
PAGE 3 of 7

HSSE CONSIDERATIONS

This section to be completed with concurrence from the Safety and Health Manager.

<i>SOURCE</i>	<i>HAZARDS</i>	<i>WHERE</i>	<i>HOW, WHEN, RESULT</i>	<i>CONTROLS</i>
CHEMICAL	<p>Potential contact with contaminated soils and water.</p> <p>Preservatives (HCL, HNO3, H2SO4, Zinc, Acetate, NaOH)</p>	<p>Sites.</p> <p>In bottles or added to bottles through sampling process</p>	<p>Inadvertent exposure to contaminated soils and water could lead to adverse health effects.</p> <p>Inadvertent exposure to preservatives could lead to adverse health effects.</p>	<p>Personnel will practice proper personal hygiene – wash hands prior to eating/drinking and when leaving the site. Employees will wear nitrile gloves and safety glasses when collecting and handling samples. Pour water from bailer into bucket, or from bucket into disposal area slowly to prevent splashes and skin contact.</p> <p>Safety Data Sheets for each preservative chemical are available to all employees on the Pioneer company web site. Personnel will wear nitrile gloves and safety glasses when adding preservatives to sample bottles. Refer to the Chemical Flushing Guidelines available inside vehicle's first aid kit for first-aid procedures in case of contact with preservatives.</p>
NOISE	Not applicable.			
ELECTRICAL	Not applicable.			
BODY MECHANICS	<p>Improper lifting and carrying tools, equipment, and/or samples.</p> <p>Bending, squatting, and kneeling.</p>	<p>Sites.</p> <p>During sample collection.</p>	<p>Back injuries and muscle/back strains could result when using improper techniques to lift and carry tools, equipment, and/or samples.</p> <p>Bending, squatting, and kneeling during</p>	<p>Personnel will use proper lifting techniques – get a good grip, keep the load close to the body, lift with legs and not with back, and avoid lifting loads above shoulder's height.</p> <p>Employees should stretch prior to starting work and they will take breaks when necessary.</p>



**SOP-GW-02;
SAMPLING WITH A BAILER**

DATE ISSUED:
12/03/2014
REVISION: 0
PAGE 4 of 7

HSSE CONSIDERATIONS

This section to be completed with concurrence from the Safety and Health Manager.

			sample collection could result in muscle/back strains or other injuries.	
GRAVITY	Falls from slips and trips.	Uneven terrain, slick/muddy/wet surfaces and steep slopes.	Walking/working on slick/muddy/wet and uneven terrain could cause slips and trips resulting in falls and injuries.	Workers will wear work boots with good traction and ankle support. Personnel will be aware of working/walking surfaces and choose a path to avoid hazards. Keep work areas as dry as possible. Wear muck boots, as necessary.
WEATHER	Cold/heat stress. Lightning.	Sites. Outdoor sites.	Exposure to cold climates may result in cold burns, frostbites, and hypothermia. Exposure to high temperatures may result in heat cramps, heat exhaustion, or heat stroke. Electrocution, injury, death, or equipment damage could be caused by lightning strike.	Training on signs and symptoms of cold/heat stress is required. Personnel will wear appropriate clothing when working outdoors. Employees will remain hydrated and will have sufficient caloric intakes during the day. Personnel will follow procedures outlined in applicable SSHASP and/or Pioneer corporate HASP. Employees will follow the 30/30 rule during lightning storms.
RADIATION	Ultraviolet (UV) radiation.	Outdoors.	Employees could be exposed to UV radiation during summer months causing sun burns, skin damage, and eye damage.	Employees will wear safety glasses with tinted lenses, long-sleeve work shirts, and long pants. Employees should wear sunscreen, if necessary.
BIOLOGICAL	Plants, insects, and animals.	Sites.	Exposure to plants, insects, and/or animals	Training on the signs and symptoms of exposure to plants, insects, and animals is



**SOP-GW-02;
SAMPLING WITH A BAILER**

DATE ISSUED:
12/03/2014
REVISION: 0
PAGE 5 of 7

HSSE CONSIDERATIONS

This section to be completed with concurrence from the Safety and Health Manager.

			may cause rashes, blisters, redness, and swelling.	required. Avoid contact with plants, insects, and animals. First-aid kits will be available on site. Employees with allergies will notify their supervisor.
MECHANICAL	Pinch points.	Well caps.	Personal injury could result from fingers getting pinched in well caps.	Personnel will wear leather gloves when removing well caps.
	Sharp tools/equipment.	Sites.	Personal injury could occur while using a knife to cut bailer line.	Personnel will use proper tools for the job. Workers cannot use leather gloves while cutting the bailer line because of the potential for cross contamination. Use extreme caution and cut away from the body. Use approved cutting device.
PRESSURE	Not applicable.			
THERMAL	Not applicable.			
HUMAN FACTORS	Inexperienced and improperly trained worker.	Sites.	Inexperienced workers and improper training could cause incidents resulting in adverse health effects and/or property damage.	Employees will be properly trained in this procedure and other applicable procedures. Employees will implement stop work procedures, if necessary.
SIMOPS	Struck by and/or caught in between heavy equipment or vehicles.	Sites.	Personnel could be injured if struck by and/or caught in between heavy equipment or vehicles while collecting samples.	Employees will communicate with the contractors on site. Personnel will avoid working near heavy equipment/vehicles, when possible. Personnel will wear high visibility clothing. When possible, personnel will park field vehicles or use traffic cones to prevent third



**SOP-GW-02;
SAMPLING WITH A BAILER**

DATE ISSUED:
12/03/2014
REVISION: 0
PAGE 6 of 7

HSSE CONSIDERATIONS

This section to be completed with concurrence from the Safety and Health Manager.

				party vehicles from coming into the work area.
--	--	--	--	--

ADDITIONAL HSSE CONSIDERATIONS

This section to be completed with concurrence from the Safety and Health Manager.

REQUIRED PPE	Hard hat, safety glasses, high-visibility work shirt or vest, long pants, work boots, and nitrile gloves.
APPLICABLE SDS	HCL, HNO ₃ , H ₂ SO ₄ , Zinc, Acetate, and NaOH. Additional Safety Data Sheets (SDSs) will be maintained based on site characterization and contaminants.
REQUIRED PERMITS/FORMS	Per site/project requirements.
ADDITIONAL TRAINING	Per site/project requirements.

DRAWINGS, DOCUMENTS, AND TOOLS/EQUIPMENT

The following documents should be referenced to assist in completing the associated task.

P&IDS	
DRAWINGS	
RELATED SOPs/PROCEDURES/WORK PLANS	SOP-DE-02 Equipment Decontamination, SOP-DE-03 Investigation Derived Waste Handling, and SOP-GW-03 Depth to Water Level Measurements.
TOOLS	Electronic depth to water level indicator, disposable or dedicated bailer, buckets, sample bottles, clean string, and field logbook.
FORMS/CHECKLIST	





**SOP-GW-02;
SAMPLING WITH A BAILER**

DATE ISSUED:
12/03/2014
REVISION: 0
PAGE 7 of 7

APPROVALS/CONCURRENCE

By signing this document, all parties acknowledge the completeness and applicability of this SOP for its intended purpose. Also, by signing this document, it serves as acknowledgement that I have received training on the procedure and associated competency testing.

SOP TECHNICAL AUTHOR	DATE
 Julie Flammang	12/03/2014
SAFETY AND HEALTH MANAGER	DATE
 Tara Schleeman	12/03/2014

Revisions:

Revision	Description	Date



**SOP-GW-02A;
SAMPLING WITH A BAILER
FOR ORGANIC COMPOUNDS**

DATE ISSUED:
12/03/2014
REVISION: 0
PAGE 1 of 7

PURPOSE	To provide standard instructions for sampling with a bailer for organic compounds.
SCOPE	This practice has been prepared for the Pioneer Technical Services, Inc. (Pioneer) workforce and applies to work carried out by and on behalf of Pioneer. All members of the Pioneer workforce who conduct the work shall be trained and competent in the risk-assessed work described below.
WORK INSTRUCTIONS	
The following instructions are intended to provide sufficient guidance to perform the task in a safe, accurate, and reliable manner. Should these instructions present information that is inaccurate or unsafe, operations personnel must bring the issue to the attention of the Project Manager and the appropriate revisions made. All work carried under this SOP will be consistent with procedures and policies described in the appropriate Operation, Maintenance, and Monitoring (O&M) Plan (where applicable), appropriate Site-Specific Health and Safety Plan (SSHASP), and Pioneer Corporate Health and Safety Plan (HASP).	
TASK	INSTRUCTIONS
1. Record the ambient air or background value.	<p>If there is potential for organic vapors to be present in a well, turn on and calibrate the appropriate field monitoring instrument (e.g., Photoionization Detector [PID]), as directed in the instruments operation manual.</p> <p>Once the instrument has been calibrated, turn the instrument on. Hold the instrument near the unopened well head. Once the reading has stabilized, record the ambient air or background value.</p>
2. Monitor the well for organic vapors.	Remove the well cap and immediately insert the probe from the field monitoring instrument (e.g., PID) into the casing (head space) to measure. Lightly cover the well with the cap, taking care not to crush the instrument probe. Monitor the instrument and record the highest measurement in the field log book. Refer to the instruments operation manual for detailed information on screening well headspace if organic vapors are present.
3. Determine water level in the well.	Using clean, non-contaminating equipment (e.g., an electronic depth to water level indicator (avoid indicating paste)), determine the water level in the well. Refer to SOP-GW-03 Depth to Water Level Measurements for instructions. If required check for the presence of free or floating product with an interface probe or clear bailer. Calculate the fluid volume in the casing and determine the appropriate purge volume required prior to sample collection.
4. Collect sample with bailer.	<p>Attach a clean, decontaminated bailer to clean line for lowering and raising the bailer into the well. A disposable or dedicated bailer is preferred. Make sure the knot will not come loose.</p> <p>Lower bailer slowly until it contacts water surface. The bailer should not contact the bottom of the well.</p> <p>Allow bailer to sink slowly and fill with a minimum of surface disturbance.</p> <p>Slowly raise bailer to surface. Do not allow bailer line to contact the ground</p>



**SOP-GW-02A;
SAMPLING WITH A BAILER
FOR ORGANIC COMPOUNDS**

DATE ISSUED:
12/03/2014
REVISION: 0
PAGE 2 of 7

	surface.
5. Discharge purge water into appropriate container.	Use bottom discharge device to slowly discharge purge water into an appropriate container, or pour slowly from top of bailer. Purge water shall be disposed of in accordance with the site-specific Sampling and Analysis Plan (SAP), client disposal requirements and/or SOP-DE-03 Investigation Derived Waste Handling.
6. Acquire sufficient purge volume.	Repeat task #4 as needed to acquire sufficient purge volume.
7. Place preservative in vials.	If water is being collected for volatile organic compounds (VOCs) analysis, place preservative in vials (if appropriate).
8. Pour water into appropriate containers.	Once sufficient purge volume has been collected, use bottom discharge device or pour slowly from top of bailer into appropriate sample containers.
9. Acquire sufficient sample volume.	Repeat task #4 as needed to acquire sufficient sample volume.
10. Cap the sample containers.	Check that a Teflon liner is present in cap, if one is required. Secure the cap tightly. For VOC analysis, check for air bubbles after securing the cap. To check for air bubbles: turn the VOC bottle upside down, tap lightly, turn right side up, see if any bubbles float to the top. If you see a bubble, remove lid, add additional water, and reseal.
11. Label the samples.	Label the sample bottle with an appropriate tag/label. Be sure to complete the tag with necessary information. Record the information in the field logbook and complete all chain-of-custody documents.
12. Transport the samples.	Immediately place the properly labeled sample bottle in an appropriate carrying container (e.g., cooler) maintained at 4°C +/- 2°C throughout the sampling and transportation period.



**SOP-GW-02A;
SAMPLING WITH A BAILER
FOR ORGANIC COMPOUNDS**

DATE ISSUED:
12/03/2014
REVISION: 0
PAGE 3 of 7

HSSE CONSIDERATIONS

This section to be completed with concurrence from the Safety and Health Manager.

<i>SOURCE</i>	<i>HAZARDS</i>	<i>WHERE</i>	<i>HOW, WHEN, RESULT</i>	<i>CONTROLS</i>
CHEMICAL	Potential contact with contaminated soils and water.	Sites.	Inadvertent exposure to contaminated soils and water could lead to adverse health effects.	Personnel will practice proper personal hygiene – wash hands prior to eating/drinking and when leaving the site. Employees will wear nitrile gloves and safety glasses when collecting and handling samples. Pour water from bailer into bucket, or from bucket into disposal area slowly to prevent splashes and skin contact.
	Toxic levels of organic vapors.	Sites.	Inadvertent exposure (inhalation) to toxic levels of organic vapors, when collecting samples, could lead to adverse health effects.	Personnel will monitor the ambient air near the unopened well head and inside the well for toxic organic vapors. If toxic levels of organic vapors are present, stop work and contact the Safety and Health Manager. Make sure the work area is well ventilated prior to starting work.
	Preservatives (HCL, HNO3, H2SO4, Zinc, Acetate, NaOH)	In bottles or added to bottles through sampling process	Inadvertent exposure to preservatives could lead to adverse health effects.	Safety Data Sheets for each preservative chemical are available to all employees on the Pioneer company web site. Personnel will wear nitrile gloves and safety glasses when adding preservatives to sample bottles. Refer to the Chemical Flushing Guidelines available inside vehicle's first aid kit for first-aid procedures in case of contact with preservatives.
NOISE	Not applicable.			
ELECTRICAL	Not applicable.			



**SOP-GW-02A;
SAMPLING WITH A BAILER
FOR ORGANIC COMPOUNDS**

DATE ISSUED:
12/03/2014
REVISION: 0
PAGE 4 of 7

BODY MECHANICS	<p>Improper lifting and carrying tools, equipment, and/or samples.</p> <p>Bending, squatting, and kneeling.</p>	<p>Sites.</p> <p>During sample collection.</p>	<p>Back injuries and muscle/back strains could result when using improper techniques to lift and carry tools, equipment, and/or samples.</p> <p>Bending, squatting, and kneeling during sample collection could result in muscle/back strains or other injuries.</p>	<p>Personnel will use proper lifting techniques – get a good grip, keep the load close to the body, lift with legs and not with back, and avoid lifting loads above shoulder’s height. Two workers will lift objects, if necessary.</p> <p>Employees should stretch prior to starting work and they will take breaks when necessary.</p>
GRAVITY	<p>Falls from slips and trips.</p>	<p>Uneven terrain, slick/muddy/wet surfaces and steep slopes.</p>	<p>Walking/working on slick/muddy/wet and uneven terrain could cause slips and trips resulting in falls and injuries.</p>	<p>Workers will wear work boots with good traction and ankle support. Personnel will be aware of working/walking surfaces and choose a path to avoid hazards. Keep work areas as dry as possible. Wear muck boots, as necessary.</p>
WEATHER	<p>Cold/heat stress.</p> <p>Lightning.</p>	<p>Sites.</p> <p>Outdoor sites.</p>	<p>Exposure to cold climates may result in cold burns, frostbites, and hypothermia. Exposure to high temperatures may result in heat cramps, heat exhaustion, or heat stroke.</p> <p>Electrocution, injury, death, or equipment damage could be caused by lightning strike.</p>	<p>Training on signs and symptoms of cold/heat stress is required. Personnel will wear appropriate clothing when working outdoors. Employees will remain hydrated and will have sufficient caloric intakes during the day. Personnel will follow procedures outlined in applicable SSHASP and/or Pioneer corporate HASP.</p> <p>Employees will follow the 30/30 rule during lightning storms.</p>



**SOP-GW-02A;
SAMPLING WITH A BAILER
FOR ORGANIC COMPOUNDS**

DATE ISSUED:
12/03/2014
REVISION: 0
PAGE 5 of 7

RADIATION	Ultraviolet (UV) radiation.	Outdoors.	Employees could be exposed to UV radiation during summer months causing sun burns, skin damage, and eye damage.	Employees will wear safety glasses with tinted lenses, long-sleeve work shirts, and long pants. Employees should wear sunscreen, if necessary.
BIOLOGICAL	Plants, insects, and animals.	Sites.	Exposure to plants, insects, and/or animals may cause rashes, blisters, redness, and swelling.	Training on the signs and symptoms of exposure to plants, insects, and animals is required. Avoid contact with plants, insects, and animals. First-aid kits will be available on site. Employees with allergies will notify their supervisor.
MECHANICAL	Pinch Points. Sharp tools/equipment.	Well caps. Sites.	Personal injury could result from fingers getting pinched in well caps. Personal injury could occur while using a knife to cut bailer line.	Personnel will wear leather gloves when removing well caps. Personnel will use proper tools for the job. Workers cannot use leather gloves while cutting the bailer line because of the potential for cross contamination. Use extreme caution and cut away from the body. Use approved cutting device.
PRESSURE	Not applicable.			
THERMAL	Not applicable.			
HUMAN FACTORS	Inexperienced and improperly trained worker.	Sites.	Inexperience workers and improper training could cause incidents resulting in adverse health effects and/or property damage.	Employees will be properly trained in this procedure and other applicable procedures. Employees will implement stop work procedures, if necessary.



**SOP-GW-02A;
SAMPLING WITH A BAILER
FOR ORGANIC COMPOUNDS**

DATE ISSUED:
12/03/2014
REVISION: 0
PAGE 6 of 7

SIMOPS	Struck by and/or caught in between heavy equipment or vehicles.	Sites.	Personnel could be injured if struck by and/or caught in between heavy equipment or vehicles while collecting samples.	Employees will communicate with the contractors on site. Personnel will avoid working near heavy equipment/vehicles, when possible. Personnel will wear high visibility clothing. When possible, personnel will park field vehicles or use traffic cones to prevent third party vehicles from coming into the work area.
---------------	---	--------	--	--

ADDITIONAL HSSE CONSIDERATIONS

This section to be completed with concurrence from the Safety and Health Manager.

REQUIRED PPE	Hard hat, safety glasses, high-visibility work shirt or vest, long pants, work boots, and nitrile gloves.
APPLICABLE SDS	HCL, HNO ₃ , H ₂ SO ₄ , Zinc, Acetate, and NaOH. Additional Safety Data Sheets (SDSs) will be maintained based on site characterization and contaminants.
REQUIRED PERMITS/FORMS	Per site/project requirements.
ADDITIONAL TRAINING	Per site/project requirements.

DRAWINGS, DOCUMENTS, AND TOOLS/EQUIPMENT

The following documents should be referenced to assist in completing the associated task.

P&IDS	
DRAWINGS	
RELATED SOPs/PROCEDURES/WORK PLANS	SOP-DE-02 Equipment Decontamination, SOP-DE-03 Investigation Derived Waste Handling, and SOP-GW-03 Depth to Water Level Measurements.
TOOLS	Field monitoring instruments (e.g., PID), electronic depth to water level indicator, disposable or designated bailer, buckets, sample bottles, clean string, and field logbook. Additional decontamination solvents may be needed as indicated in the SAP or Quality Assurance Project Plan (QAPP).
FORMS/CHECKLIST	





**SOP-GW-02A;
SAMPLING WITH A BAILER
FOR ORGANIC COMPOUNDS**

DATE ISSUED:
12/03/2014
REVISION: 0
PAGE 7 of 7

APPROVALS/CONCURRENCE

By signing this document, all parties acknowledge the completeness and applicability of this SOP for its intended purpose. Also, by signing this document, it serves as acknowledgement that I have received training on the procedure and associated competency testing.

SOP TECHNICAL AUTHOR	DATE
 Julie Flammang	12/03/2014
SAFETY AND HEALTH MANAGER	DATE
 Tara Schleeman	12/03/2014

Revisions:

Revision	Description	Date



**SOP-GW-03;
DEPTH TO WATER LEVEL
MEASUREMENTS**

DATE ISSUED:
12/03/2014
REVISION: 0
PAGE 1 of 6

PURPOSE	To provide standard instructions for conducting depth to water level measurements.
SCOPE	This practice has been prepared for the Pioneer Technical Services, Inc. (Pioneer) workforce and applies to work carried out by and on behalf of Pioneer. All members of the Pioneer workforce who conduct the work shall be trained and competent in the risk-assessed work described below.

WORK INSTRUCTIONS

The following instructions are intended to provide sufficient guidance to perform the task in a safe, accurate, and reliable manner. Should these instructions present information that is inaccurate or unsafe, operations personnel must bring the issue to the attention of the Project Manager and the appropriate revisions made. All work carried under this SOP will be consistent with procedures and policies described in the appropriate Operation, Maintenance, and Monitoring (O&M) Plan (where applicable), appropriate Site-Specific Health and Safety Plan (SSHASP), and Pioneer Corporate Health and Safety Plan (HASP).

TASK	INSTRUCTIONS
Electric Depth to Water Indicator	
1. Inspect well casing.	Inspect well and casing for a marked measuring point. If no measuring point is marked, locate the north side of the well and establish a marking point. Choose the point for ease of accurately reading the measuring tape.
2. Test the water level indicator.	Test that the water level indicator is on and working by pushing the test button on the indicator and checking the buzzer sound level and/or checking for the light. Make sure the equipment is clean and decontaminated per SOP-DE-02 Equipment Decontamination.
3. Lower the sensor.	Lower the sensor probe slowly into the well to minimized disturbance of water when it is encountered. As the sensor is lowered down the well, the buzzer and/or flashing light will indicate contact with water. Be aware that sensor may indicate water prior to actual water level, if the probe contacts condensation on the well casing.
4. Align probe cable.	Once the buzzer has sounded, align the marked probe cable with the designated marking point and gently raise and lower the probe until the exact mark on the probe cable, when water is encountered, is identified.
5. Record information.	Record this information in the project logbook as the depth to water (DTW). In addition, record where the marking point was located (e.g., top of casing [TOC], top of PVC [TOPVC], inner PVC [IPVC]) to help maintain continuity, if subsequent DTW readings are needed from this well.
6. Reel in equipment.	Reel in sensor probe.



**SOP-GW-03;
DEPTH TO WATER LEVEL
MEASUREMENTS**

DATE ISSUED:
12/03/2014
REVISION: 0
PAGE 2 of 6

7. Decontaminate equipment.	Decontaminate all equipment prior to re-use per SOP-DE-02 Equipment Decontamination.
Chalked Measuring Tape Depth to Water Measurements	
1. Coat tape with chalk.	Make sure the equipment is clean and decontaminated per SOP-DE-02 Equipment Decontamination. Coat the lower three to five feet of tape with chalk and lower into well. Listen for weight to contact water and lower tape an additional 0.5 foot.
2. Record information.	Record measure point and pull tape carefully from well. Read the wetted chalk mark and record. Subtract the wetted chalk mark from the measure point for true depth to water.
3. Decontaminate equipment.	Decontaminate all equipment prior to re-use per SOP-DE-02 Equipment Decontamination.



**SOP-GW-03;
DEPTH TO WATER LEVEL
MEASUREMENTS**

DATE ISSUED:
12/03/2014
REVISION: 0
PAGE 3 of 6

HSSE CONSIDERATIONS

This section to be completed with concurrence from the Safety and Health Manager.

<i>SOURCE</i>	<i>HAZARDS</i>	<i>WHERE</i>	<i>HOW, WHEN, RESULT</i>	<i>CONTROLS</i>
CHEMICAL	Potential contact with contaminated water.	Sites.	Inadvertent exposure to contaminated soils and water could lead to adverse health effects.	Personnel will practice proper personal hygiene – wash hands prior to eating/drinking and when leaving the site. Employees will wear nitrile gloves and safety glasses when collecting and handling samples.
NOISE	Not applicable.			
ELECTRICAL	Not applicable.			
BODY MECHANICS	Bending, squatting, and kneeling.	During depth measurements.	Bending, squatting, and kneeling during depth measurements could result in muscle/back strains or other injuries.	Employees should stretch prior to starting work and they will take breaks when necessary.
GRAVITY	Falls from slips and trips.	Uneven terrain, slick/muddy/wet surfaces and steep slopes.	Walking/working on slick/muddy/wet and uneven terrain could cause slips and trips resulting in falls and injuries.	Workers will wear work boots with good traction and ankle support. Personnel will be aware of working/walking surfaces and choose a path to avoid hazards. Keep work areas as dry as possible. Wear muck boots, as necessary.
WEATHER	Cold/heat stress.	Sites.	Exposure to cold climates may result in cold burns, frostbites, and hypothermia. Exposure to high temperatures may result in heat cramps, heat exhaustion, or heat stroke.	Training on signs and symptoms of cold/heat stress is required. Personnel will wear appropriate clothing when working outdoors. Employees will remain hydrated and will have sufficient caloric intakes during the day. Personnel will follow procedures outlined in applicable SSHASP and/or Pioneer corporate HASP.



**SOP-GW-03;
DEPTH TO WATER LEVEL
MEASUREMENTS**

DATE ISSUED:
12/03/2014
REVISION: 0
PAGE 4 of 6

	Lightning.	Outdoor sites.	Electrocution, injury, death, or equipment damage could be caused by lightning strike.	Employees will follow the 30/30 rule during lightning storms.
RADIATION	Ultraviolet (UV) radiation.	Outdoors.	Employees could be exposed to UV radiation during summer months causing sun burns, skin damage, and eye damage.	Employees will wear safety glasses with tinted lenses, long-sleeve work shirts, and long pants. Employees should wear sunscreen, if necessary.
BIOLOGICAL	Plants, insects, and animals.	Sites and well casings.	Exposure to plants, insects, and/or animals may cause rashes, blisters, redness, and swelling.	Training on the signs and symptoms of exposure to plants, insects, and animals is required. Avoid contact with plants, insects, and animals. First-aid kits will be available on site. Employees with allergies will notify their supervisor.
MECHANICAL	Scrapes and cuts.	Well casing.	Scrapes and cuts could result, when taking measurements, from sharp edges in metals or PVC casings.	Employees will inspect well casing for sharp edges. If edges are very sharp, employees will wear leather gloves.
PRESSURE	Not applicable.			
THERMAL	Not applicable.			
HUMAN FACTORS	Inexperienced and improperly trained worker.	Sites.	Inexperienced workers and improper training could cause incidents resulting in adverse health effects and/or property damage.	Employees will be properly trained in this procedure and other applicable procedures. Employees will implement stop work procedures, if necessary.



**SOP-GW-03;
DEPTH TO WATER LEVEL
MEASUREMENTS**

DATE ISSUED:
12/03/2014
REVISION: 0
PAGE 5 of 6

SIMOPS	Struck by and/or caught in between heavy equipment or vehicles.	Sites.	Personnel could be injured if struck by and/or caught in between heavy equipment or vehicles while collecting samples.	Employees will communicate with the contractors on site. Personnel will avoid working near heavy equipment/vehicles, when possible. Personnel will wear high visibility clothing. When possible, personnel will park field vehicles or use traffic cones to prevent third party vehicles from coming into the work area.
---------------	---	--------	--	--

ADDITIONAL HSSE CONSIDERATIONS

This section to be completed with concurrence from the Safety and Health Manager.

REQUIRED PPE	Hard hat, safety glasses, high-visibility work shirt or vest, long pants, work boots, and nitrile gloves.
APPLICABLE SDS	Safety Data Sheets (SDSs) will be maintained based on site characterization and contaminants.
REQUIRED PERMITS/FORMS	Per site/project requirements.
ADDITIONAL TRAINING	Per site/project requirements.

DRAWINGS, DOCUMENTS, AND TOOLS/EQUIPMENT

The following documents should be referenced to assist in completing the associated task.

P&IDS	
DRAWINGS	Map with well locations.
RELATED SOPs/PROCEDURES/WORK PLANS	SOP-DE-02 Equipment Decontamination.
TOOLS	Water level indicator or measuring tape and chalk, and field logbook.
FORMS/CHECKLIST	





**SOP-GW-03;
DEPTH TO WATER LEVEL
MEASUREMENTS**

DATE ISSUED:
12/03/2014
REVISION: 0
PAGE 6 of 6

APPROVALS/CONCURRENCE

By signing this document, all parties acknowledge the completeness and applicability of this SOP for its intended purpose. Also, by signing this document, it serves as acknowledgement that I have received training on the procedure and associated competency testing.

SOP TECHNICAL AUTHOR	DATE
 Julie Flammang	12/03/2014
SAFETY AND HEALTH MANAGER	DATE
 Tara Schleeman	12/03/2014

Revisions:

Revision	Description	Date



**SOP-GW-10C;
PURGING AND SAMPLING
WITH A PERISTALTIC PUMP**

DATE ISSUED:
12/11/2014
REVISION: 0
PAGE 1 of 7

PURPOSE	To provide standard instructions for purging and sampling with a peristaltic pump.
SCOPE	This practice has been prepared for the Pioneer Technical Services, Inc. (Pioneer) workforce and applies to work carried out by and on behalf of Pioneer. All members of the Pioneer workforce who conduct the work shall be trained and competent in the risk-assessed work described below.
WORK INSTRUCTIONS	
The following instructions are intended to provide sufficient guidance to perform the task in a safe, accurate, and reliable manner. Should these instructions present information that is inaccurate or unsafe, operations personnel must bring the issue to the attention of the Project Manager and the appropriate revisions made. All work carried under this SOP will be consistent with procedures and policies described in the appropriate Operation, Maintenance, and Monitoring (O&M) Plan (where applicable), appropriate Site-Specific Health and Safety Plan (SSHASP), and Pioneer Corporate Health and Safety Plan (HASP).	
TASK	INSTRUCTIONS
Note	Sampling wells in order of increasing chemical concentrations is preferred.
1. Determine the water level in the well.	Using clean, non-contaminating equipment (e.g., an electronic depth to water level indicator (avoid indicating paste)), per SOP-DE-02 Equipment Decontamination, determine the water level in the well. Refer to SOP-GW-03 Depth to Water Level Measurements for instructions. Calculate the fluid volume in the case (“casing volume”) and record in the logbook. If depth to mid-point of screen is over 8 meters, choose alternative system.
2. Measure tubing to be used.	Measure the appropriate amount of disposable or decontaminated tubing to be inserted into the well. Add an additional two to four feet of tubing that will remain outside the well and attach to the soft tubing in the peristaltic pump. Teflon or Teflon lined tubing is preferred when sampling for volatile organic compounds (VOCs), semivolatile organic compounds (SVOCs), pesticides, and polychlorinated biphenyl (PCBs). Polyvinyl chloride (PVC), polyethylene and polypropylene tubing can be used when sampling for inorganics.
3. Insert tubing into the well.	Insert the tubing into the well to the predetermined sampling zone. The mid-point of the saturated screen is used by convention as the location of the tubing end. Chemical concentrations or permeability considerations may require tubing placement in a different zone. This will be indicated in the Sampling Analysis Plan (SAP) or work plan. If possible keep the tubing at least 2 feet from the bottom of the well to avoid mobilization of particulates in the bottom of the well.
4. Measure and record the discharge rate.	Insert the soft tubing into the peristaltic pump following the instructions in the operating manual. Insert the hard tubing into the soft tubing end. Start the pump head and adjust the pump speed until an appropriate discharge rate is achieved. The pump should discharge at an extraction rate that avoids drawing down the water level below the pump intake. Measure the discharge rate using a bottle or beaker and a stop watch. Record this information in the logbook. If the recharge rate is slower than an attainable extraction rate using the pump and the well becomes



**SOP-GW-10C;
PURGING AND SAMPLING
WITH A PERISTALTIC PUMP**

DATE ISSUED:
12/11/2014
REVISION: 0
PAGE 2 of 7

	essentially dewatered (e.g., water level falls below the intake level), the well should be allowed to recover sufficiently to fill all the appropriate sample containers. If possible, do not move the pump intake during this process. Samples may then be collected.
5. Dispose of purged water and record total purge volume.	Collect and dispose of purged water in accordance with SOP-DE-03 Investigation Derived Waste Handling. Measure and record the total purge volume.
6. Monitor and record field parameters and depth to water level measurements.	<p>During well purging, monitor indicator field parameters including pH, conductivity, and temperature. The SAP or work plan may indicate other field parameters that need to be monitored, such as eH, dissolved oxygen (DO), and turbidity. Water quality parameters will be considered stable when three consecutive readings (generally 2-5 minutes apart) are as follows:</p> <ul style="list-style-type: none"> a. Temperature range is no more than +/- 1 degree Celsius (°C); b. pH varies by no more than 0.1 pH units; and c. Specific conductivity readings are within 3% of the average. <p>Field parameters should be recorded in the logbook or on field data sheets.</p>
7. Collect samples.	<p>Purge a minimum of three casing volumes and/or until water quality parameters stabilize. Once these conditions occur, sampling can commence. In general, VOC samples should not be collected when using a peristaltic pump. If VOC analysis is required, collect the VOC samples first and then place them directly into pre-preserved sample containers. Fill the sample containers by allowing pump discharge to flow gently down the side of the bottle with minimal entry turbulence. Double check for bubbles as this method tends to produce them. Cap each bottle as filled. Add preservative as required by analytical methods to samples immediately after collection, if not collected in pre-preserved containers.</p> <p>If a filtered sample is required, an in-line high capacity (0.45 µm) should be inserted into the discharge end of the soft tubing after the other sample containers are filled. Fill the sample bottle and preserve immediately; cap the bottle.</p> <p>To check for air bubbles: turn the VOC bottle upside down, tap lightly, turn right side up, see if any bubbles float to the top. If you see a bubble, remove lid, add additional water, and reseal.</p>
8. Label sample bottles.	Label the sample bottle with an appropriate tag/label. Be sure to complete the tag with necessary information. Record the information in the field logbook and complete all chain-of-custody documents.
9. Transport sample bottles.	Place the properly labeled sample bottles in an appropriate carrying container maintained at 4°C +/- 2°C throughout the sampling and transportation period.



**SOP-GW-10C;
PURGING AND SAMPLING
WITH A PERISTALTIC PUMP**

DATE ISSUED:
12/11/2014
REVISION: 0
PAGE 3 of 7

10. Dispose of used tubing.	Tubing used in the well sampling will be disposed of in accordance with SOP-DE-03 Investigation Derived Waste Handling.
-----------------------------	---



**SOP-GW-10C;
PURGING AND SAMPLING
WITH A PERISTALTIC PUMP**

DATE ISSUED:
12/11/2014
REVISION: 0
PAGE 4 of 7

HSSE CONSIDERATIONS				
This section to be completed with concurrence from the Safety and Health Manager.				
<i>SOURCE</i>	<i>HAZARDS</i>	<i>WHERE</i>	<i>HOW, WHEN, RESULT</i>	<i>CONTROLS</i>
CHEMICAL	<p>Potential contact with contaminated soils and water.</p> <p>Preservatives (HCL, HNO₃, H₂SO₄, Zinc, Acetate, NaOH).</p>	<p>Sites.</p> <p>In bottles or added to bottles through sampling process.</p>	<p>Inadvertent exposure to contaminated soils and water could lead to adverse health effects.</p> <p>Inadvertent exposure to preservatives could lead to adverse health effects.</p>	<p>Personnel will practice proper personal hygiene – wash hands prior to eating/drinking and when leaving the site. Employees will wear nitrile gloves and safety glasses when collecting and handling samples. Pour water from bucket into disposal area slowly to prevent splashes and skin contact.</p> <p>Safety Data Sheets for each preservative chemical are available to all employees on the Pioneer company web site. Personnel will wear nitrile gloves and safety glasses when adding preservatives to samples bottles. Refer to the Chemical Flushing Guidelines available inside vehicle's first aid kit for first-aid procedures in case of contact with preservatives.</p>
NOISE	Not applicable.			
ELECTRICAL	Not applicable.			
BODY MECHANICS	<p>Improper lifting.</p> <p>Bending, squatting, and kneeling.</p>	<p>Testing sites.</p> <p>During sample collection.</p>	<p>Back injuries and muscle/back strains could result when using improper techniques to lift and carry tools and equipment.</p> <p>Bending, squatting, and kneeling during sample collection</p>	<p>Personnel will use proper lifting techniques – get a good grip, keep the load close to the body, lift with legs and not with back, and avoid lifting loads above shoulder's height. Two people will lift objects, if necessary.</p> <p>Employees should stretch prior to starting work and they will take breaks when necessary.</p>



**SOP-GW-10C;
PURGING AND SAMPLING
WITH A PERISTALTIC PUMP**

DATE ISSUED:
12/11/2014
REVISION: 0
PAGE 5 of 7

			could result in muscle/back strains or other injuries.	
GRAVITY	Falls from slips and trips.	Uneven terrain, slick/muddy/wet surfaces and steep slopes.	Walking/working on slick/muddy/wet and uneven terrain could cause slips and trips resulting in falls and injuries.	Workers will wear work boots with good traction and ankle support. Personnel will be aware of working/walking surfaces and choose a path to avoid hazards. Keep work areas as dry as possible. Wear muck boots, as necessary.
WEATHER	Cold/heat stress. Lightning.	Sites. Outdoor sites.	Exposure to cold climates may result in cold burns, frostbites, and hypothermia. Exposure to high temperatures may result in heat cramps, heat exhaustion, or heat stroke. Electrocution, injury, death, or equipment damage could be caused by lightning strike.	Training on signs and symptoms of cold/heat stress is required. Personnel will wear appropriate clothing when working outdoors. Employees will remain hydrated and will have sufficient caloric intakes during the day. Personnel will follow procedures outlined in applicable SSHASP and/or Pioneer corporate HASP. Employees will follow the 30/30 rule during lightning storms.
RADIATION	Ultraviolet (UV) radiation.	Outdoors.	Employees could be exposed to UV radiation during summer months causing sun burns, skin damage, and eye damage.	Employees will wear safety glasses with tinted lenses, long-sleeve work shirts, and long pants. Employees should wear sunscreen, if necessary.
BIOLOGICAL	Plants, insects, and animals.	Sites.	Exposure to plants, insects, and/or animals may cause rashes, blisters, redness, and swelling.	Training on the signs and symptoms of exposure to plants, insects, and animals is required. Avoid contact with plants, insects, and animals. First-aid kits will be available



**SOP-GW-10C;
PURGING AND SAMPLING
WITH A PERISTALTIC PUMP**

DATE ISSUED:
12/11/2014
REVISION: 0
PAGE 6 of 7

				on site. Employees with allergies will notify their supervisor.
MECHANICAL	Pinch points.	Well caps.	Personal injury could result from fingers getting pinched in the well cap.	Personnel will wear leather gloves when removing well caps.
PRESSURE	Not applicable.			
THERMAL	Not applicable.			
HUMAN FACTORS	Inexperienced and improperly trained worker.	Sites.	Inexperienced workers and improper training could cause incidents resulting in adverse health effects and/or property damage.	Employees will be properly trained in this procedure and other applicable procedures. Employees will implement stop work procedures, if necessary.
SIMOPS	Struck by and/or caught in between heavy equipment or vehicles.	Sites.	Personnel could be injured if struck by and/or caught in between heavy equipment or vehicles while collecting samples.	Employees will communicate with the contractors on site. Personnel will avoid working near heavy equipment/vehicles, when possible. Personnel will wear high visibility clothing. When possible, personnel will park field vehicles or use traffic cones to prevent third party vehicles from coming into the work area.

ADDITIONAL HSSE CONSIDERATIONS

This section to be completed with concurrence from the Safety and Health Manager.

REQUIRED PPE	Hard hat, safety glasses, high-visibility work shirt or vest, long pants, work boots, nitrile gloves, and leather gloves.
APPLICABLE SDS	HCL, HNO3, H2SO4, Zinc, Acetate, and NaOH. Additional Safety Data Sheets (SDSs) will be maintained based on site characterization and contaminants.
REQUIRED PERMITS/FORMS	Per site/project requirements.





**SOP-GW-10C;
PURGING AND SAMPLING
WITH A PERISTALTIC PUMP**

DATE ISSUED:
12/11/2014
REVISION: 0
PAGE 7 of 7

ADDITIONAL TRAINING	Per site/project requirements.
----------------------------	--------------------------------

DRAWINGS, DOCUMENTS, AND TOOLS/EQUIPMENT	
The following documents should be referenced to assist in completing the associated task.	
P&IDS	
DRAWINGS	Map with site location and sample locations.
RELATED SOPs/PROCEDURES/WORK PLANS	SOP-DE-02 Equipment Decontamination, SOP-DE-03 Investigation Derived Waste Handling, and SOP-GW-03 Depth to Water Level Measurements.
TOOLS	Sample bottles, water quality meters, 5-gallon buckets, electronic depth to water level indicator, peristaltic pump, stop watch, cooler, and field logbook.
FORMS/CHECKLIST	

APPROVALS/CONCURRENCE	
By signing this document, all parties acknowledge the completeness and applicability of this SOP for its intended purpose. Also, by signing this document, it serves as acknowledgement that I have received training on the procedure and associated competency testing.	
SOP TECHNICAL AUTHOR	DATE
 Julie Flammang	12/11/2014
SAFETY AND HEALTH MANAGER	DATE
 Tara Schleeman	12/11/2014

Revisions:

Revision	Description	Date



**SOP-GW-11;
GROUNDWATER MONITORING
WELL DESIGN AND
CONSTRUCTION**

**AUTHORIZED VERSION:
04/23/2018
PAGE 1 of 12**

PURPOSE	To provide standard instructions for groundwater monitoring well design and construction.
SCOPE	This practice is for the Pioneer Technical Services, Inc. (Pioneer) workforce and applies to work carried out by and on behalf of Pioneer. All members of the Pioneer workforce who conduct the work shall be trained and competent in the risk-assessed procedure described below.
NOTE	<p>A set procedure for designing and constructing groundwater monitoring wells cannot be presented as a standardized operating procedure. Every location within a site may vary depending on contamination encountered, lithology of the subsurface, and depth to groundwater. A technique that may work at one location may be inappropriate at the next. The following sections discuss general guidelines for well design and construction, but actual well designs will depend on specific site conditions and the associated contaminants of concern.</p> <p>Wells drilled for a Comprehensive Environmental Response, Compensation, and Liability Act (CERCLA) investigation will be designed to specifications suggested by the site being investigated, provided such design presents no conflict with investigation sampling objectives. This policy will permit the site to incorporate any new wells into on-going monitoring programs by ensuring that new wells are constructed in the same manner as existing wells. Conflicts may result when existing well construction is not suitable for the proposed sampling. For example, polyvinyl chloride (PVC) casing will not be used, if the site is contaminated with high-concentrations of organic compounds, even though existing wells contain PVC casings. Such conflicts will be resolved on a site-specific, case-by-case basis. The method of well construction and the materials used in the casing and screen affect the quality of the well, and its utility for groundwater monitoring, throughout its lifetime.</p> <p>The elements of proper monitoring well construction presented serve as guides for any wells constructed for the groundwater investigation. In addition, these guidelines can be applied to evaluate the adequacy of existing wells when sampling will be conducted from available wells.</p>

WORK INSTRUCTIONS

The following instructions are intended to provide sufficient guidance to perform the task in a safe, accurate, and reliable manner. Should these instructions present information that is inaccurate or unsafe, operations personnel must bring the issue to the attention of the Project Manager and the appropriate revisions made. All work performed under this Standard Operating Procedure (SOP) will be consistent with procedures and policies described in the appropriate Operation, Maintenance, and Monitoring (O&M) Plan (where applicable), appropriate Site-Specific Health and Safety Plan (SSHASP), and Pioneer Corporate Health and Safety Plan (HASP).

TASK	INSTRUCTIONS
1. Coordinate utility locates.	Prior to starting work, the drilling subcontractor will have a utility locate and marking performed.
2. Conduct a site walk.	Verify utility locates have been performed. Walk through the site and determine any site-specific hazards associated with the work area. Discuss these hazards with site personnel and note them in the field logbook. Verify the utility locate information



**SOP-GW-11;
GROUNDWATER MONITORING
WELL DESIGN AND
CONSTRUCTION**

**AUTHORIZED VERSION:
04/23/2018
PAGE 2 of 12**

	by identifying where natural gas pipes or other utilities enter any structures on the property or if yard lights or street lights are present with no overhead lines.
3. Select well diameter.	The diameter of the well casing will be the minimum that allows the sampling and/or monitoring equipment to be lowered to the desired depth. The diameter of the borehole into which the casing is placed must be large enough for the casing to fit and have sufficient annular space for the addition of a filter pack and well seal. The diameter of the borehole should be at least 4 inches larger than the casing to provide a minimum 2-inch annular space. When using direct push methods for well installation, the use of prepacked well screens and foam bridge/prepacked bentonite seals are necessary to install wells in smaller boreholes under saturated conditions.
4. Determine well depth.	Wells will be constructed to be depth discrete and to be sampled from one aquifer zone without interference from other zones. This requires provisions for grouting above, and if necessary, below the well screen on the outside of the casing. The location of the screen will be important for sampling since it has an impact on sampling of immiscible organics. Sampling of less dense or more dense organics, which float or sink, will require the screen to be placed at the appropriate depth.
5. Select well casings and screens.	<p>Well casings and screens will be constructed of materials with the least potential for affecting the water quality parameters of the sample. Guidance/criteria regarding casing and screen material selection is presented in various U.S. Environmental Protection Agency (EPA) guidance documents. Well casings and screens will be cleaned and protected from contamination prior to their installation. Factory cleaned screen and casing stored in plastic protective wrap may be used instead of field decontamination of well materials.</p> <p>Selection of screen and slot style are important factors in screen selection. Saw-slot style screens offer less screen open area than the Vee-wire continuous wrap screens making the saw-slot screens far less efficient in terms of producing water. Pre-packed wells screens available from many vendors offer the alternative to set well screen and filter pack in one operation, guaranteeing accurate filter pack placement.</p>
6. Define well drilling method.	Drilling method selection will be based on minimizing both the disturbance of the geologic materials penetrated, and the introduction of air, fluids, and muds. Additionally, some drilling methods are better at collecting soil samples during drilling operations for subsurface characterization. Rotary sonic is one such method that collects quality soil cores for logging and characterization purposes. The direct push technology has also become increasingly popular for the installation of small diameter wells that significantly decreases the volumes of investigation derived waste. Mud rotary drilling that utilizes either bentonite or a polymer-based drilling muds will be avoided. Advantages and disadvantages of various drilling methods are also discussed in EPA guidance documents.
7. Select monitoring well filter pack and annular sealant.	The materials used to construct the filter pack should be chemically inert (e.g., clean quartz sand, silica, or glass beads), well rounded, and dimensionally stable. Natural gravel packs are acceptable, provided that a sieve analysis is performed to establish the appropriate well screen slot size and determine chemical inertness of the filter



**SOP-GW-11;
GROUNDWATER MONITORING
WELL DESIGN AND
CONSTRUCTION**

**AUTHORIZED VERSION:
04/23/2018
PAGE 3 of 12**

pack materials in anticipated environments. Typically, 10-20 mesh silica sand is used to construct most monitoring wells utilizing screens with slot sizes of 0.010 or 0.020 inches. The prepack well screen option typically uses 0.010-inch slotted screen with 20-40 mesh silica sand contained within an outer layer of 65 mesh stainless steel screen.

The materials used to seal the annular space must prevent the migration of contaminants from the surface or intermediate zones to the sampling zone and prevent cross contamination between strata. The materials should be chemically compatible with the anticipated contaminants to ensure seal integrity during the life of the monitoring well and chemically inert so they do not affect the quality of the groundwater samples. The permeability of the sealants should be one to two orders of magnitude less than the surrounding formation. An example of an appropriate use of annular sealant material is using a minimum of 2 feet of certified sodium bentonite pellets immediately over the filter pack when in a saturated zone. Bentonite pellets are best used in a saturated zone because they will sink in the column of water before hydrating and create an effective seal. Deep water columns may require the use of coated bentonite pellets to allow the bentonite to sink before hydrating. Coarse grit sodium bentonite is likely to hydrate in the water column and bridge before reaching the filter pack and therefore should only be used to install seals above the water table. A cement and bentonite mixture, bentonite chips, or anti-shrink cement mixtures may be used as the annular sealant in the unsaturated zone above the certified-bentonite pellet seal and below the frost line. The addition of bentonite to the cement admixture should generally be in the amount of 2 to 5 percent by weight of cement content. This will aid in reducing shrinkage and control time of setting. However, field experience has demonstrated that pure bentonite installed in the vadose zone forms a better well seal as opposed to the cement-based seals that are prone to fracturing over time. Again, the appropriate clay seal material must be selected on the basis of the environment in which it is to be used. In most cases, sodium bentonite is appropriate. Calcium bentonite may be more appropriate in calcic sediments/soils due to reduced cation exchange potential. Clays based seals should be pure (i.e., free of additives that may affect groundwater quality).

The untreated clay seal should be placed around the casing either by dropping it directly down the borehole or, if a hollow-stem auger is used, putting the bentonite between the casing and the inside of the auger stem. The use of a granular bentonite facilitates the installation of the well seal where the annular space is limited, and the use of bentonite chips presents bridging risks. In shallow monitoring wells, a tamping device or slender rod system should be used to reduce this potential of bridging. Generally, a spacing differential of 3 to 5 inches should exist between the outer diameter of the casing and the inner diameter of the auger, or the surface of the borehole to facilitate emplacement of filter pack and annular sealant. The actual volume of materials used should be recorded during well construction and compared to the calculated volume. Discrepancies between calculated volumes and volumes used require an explanation.

If a cement-bentonite seal mixture is specified, the mix should be prepared using clean water and placed in the borehole using a tremie pipe. The tremie method ensures good sealing of the borehole from the bottom.



**SOP-GW-11;
GROUNDWATER MONITORING
WELL DESIGN AND
CONSTRUCTION**

**AUTHORIZED VERSION:
04/23/2018
PAGE 4 of 12**

	<p>Upon completion of the well, installation of a suitable threaded or flanged cap or compression seal should be placed or locked in properly to prevent either tampering with the well or the entrance of foreign material into it. A ¼-inch vent hole pipe provides an avenue for the escape of gas, if a totally submerged well screen is installed. Placement of concrete or steel bumper guards around the well will prevent external damage by a vehicular collision with the exposed casing.</p>
<p>8. Design well screen.</p>	<p>The intake of the monitor well should be designed and constructed to: 1) allow sufficient groundwater flow into the well for sampling; 2) minimize the passage of formation materials (turbidity) into the well; and 3) ensure sufficient structural integrity to prevent the collapse of the intake structure.</p> <p>For wells completed in unconsolidated materials, the intake of a monitoring well should consist of a screen or slotted casing with openings sized to minimize the amount of formation material from passing through the well during development. Extraneous fine-grained material (e.g., clays and silts) that has been dislodged during drilling may be left on the screen and in the well water. These fines should be removed from the screen and filter pack during development of the well. Commercially-manufactured screens or slotted casings should be used; field slotting of screens is not acceptable.</p>
<p>9. Develop well.</p>	<p>After the installation of the monitoring well, the natural hydraulic conductivity of the formation should be restored, and all foreign sediment removed to ensure turbid-free groundwater samples.</p> <p>A variety of techniques are available for developing a well. To be effective, they require reversals or surges in flow to avoid bridging by particles, which is common when flow is continuous in one direction. These reversals or surges can be created by using surge blocks, bailers, or pumps. Formation water should be used for surging the well. Any contaminated waters produced during development will be containerized for proper disposal. In low-yielding water-bearing formations, an outside source of water may sometimes be introduced into the well to facilitate development. In these cases, this water should be chemically analyzed to evaluate its potential impact on in-situ water quality. The driller should not use air to develop the wells. All developing equipment and materials need to be decontaminated prior to developing the well.</p> <p>Refer to SOP-GW-12 Well Development Using a Modified Over-Pumping Technique for more information.</p>
<p>10. Document well design and construction.</p>	<p>Information on the design and construction of wells will be documented and may include:</p> <ul style="list-style-type: none"> • Date/time of construction. • Drilling method and drilling fluid used. • Well location (± 0.5 feet). • Borehole diameter and well casing diameter.



**SOP-GW-11;
GROUNDWATER MONITORING
WELL DESIGN AND
CONSTRUCTION**

**AUTHORIZED VERSION:
04/23/2018
PAGE 5 of 12**

	<ul style="list-style-type: none"> • Well depth (± 0.1 feet). • Drilling and lithologic logs. • Casing materials. • Screen materials and design. • Casing and screen joint type. • Screen slot size/length. • Filter pack material/size, grain analysis (D10). • Filter pack volume calculations. • Filter pack placement method. • Sealant materials (percent bentonite). • Sealant placement method. • Surface seal design/construction. • Well development procedure. • Type of protective well cap. • Ground surface elevation (± 0.01 feet). • Surveyor's pin elevation (± 0.01 feet) on concrete apron. • Top of monitoring well casing elevation (± 0.01 feet). • Top of protective steel casing elevation (± 0.01 feet). • Detailed drawing of well (include dimensions).
--	---

Specialized Well Designs

	<p>There are two cases where special monitoring well design will be used:</p> <ul style="list-style-type: none"> • Where it has been decided to use dedicated pumps to draw groundwater samples. • Where light and/or dense immiscible phases may be present. <p>If it is elected to use a dedicated system, it should be a fluorocarbon resin or stainless-steel bailer, or a dedicated positive gas displacement bladder pump composed of the same two materials. As other sampling devices that can perform at least equivalently become available, they may be employed as well.</p> <p>The introduction of this pump, however, necessitates certain changes in the well. The principal change is the addition of a 2-inch diameter pump with fluorocarbon resin outlet tubing to the well. A 4-inch interior diameter outer well casing should easily accommodate this additional equipment. However, should a larger pump (e.g., 3 inches in diameter) be required because of greater well depth or yield, a larger outer casing may prove necessary (6-inch inside diameter). The pump should be positioned midway along the screened interval, and the top of its outlet pipe should extend into the well cap.</p> <p>If light or non-aqueous phase liquids (L-NAPLs) or dense non-aqueous phase liquids (D-NAPLs) layers are presumed to be present, discrete samples must be obtained. The well system needs to be designed to allow sampling of light or dense phases by using a well screen that either extends from above the potentiometric surface for the L-NAPL sampling or slightly into the lower confining layer for DNAPL monitoring. Where well clusters are employed, one well in the cluster may</p>
--	--



**SOP-GW-11;
GROUNDWATER MONITORING
WELL DESIGN AND
CONSTRUCTION**

**AUTHORIZED VERSION:
04/23/2018
PAGE 6 of 12**

be screened at horizons where floaters are expected, another at horizons where dense phases are expected, and others within other portions of the uppermost aquifer.

A periodic check of the dedicated sampling system should be exercised to prevent damage and maximize efficiency. This inspection should include removal of samples for verification of proper function. The design of the dedicated sampling system should also allow access for regular testing of aquifer characteristics. It is also recommended that the well be periodically resurveyed using the protective casing and apron as points of reference. An option that can be exercised in constructing a monitoring well (e.g., dedicated sampler) is the use of fine sand at the top of the filter pack to reduce or minimize invasion.



**SOP-GW-11;
GROUNDWATER MONITORING
WELL DESIGN AND
CONSTRUCTION**

**AUTHORIZED VERSION:
04/23/2018
PAGE 7 of 12**

HSSE CONSIDERATIONS
This section to be completed with concurrence from the Safety and Health Manager.

<i>SOURCE</i>	<i>HAZARDS</i>	<i>WHERE</i>	<i>HOW, WHEN, RESULT</i>	<i>CONTROLS</i>
CHEMICAL	Potential contact with contaminated soils and water.	Sites.	Inadvertent exposure to contaminated soils and water could lead to adverse health effects.	Personnel will practice proper personal hygiene – wash hands prior to eating/drinking and when leaving the site. Personnel will wear nitrile gloves and safety glasses when contact with soils and water is possible.
	Exposure to hydraulic fluids.	Drilling operations.	Exposure to hydraulic fluids could occur while operating and working around the drill due to equipment malfunction/failure resulting in personal injuries.	The operator will inspect the drill and document inspections daily before starting work. The operator will also replace/repair all faulty equipment before starting work. When inspecting equipment, personnel will wear work gloves to prevent possible exposures to hydraulic fluids. Non-essential personnel will maintain a 20-foot buffer zone around the drill.
	Contact with gasoline/diesel.	Fueling equipment.	Inadvertent exposure via inhalation and/or skin contact can result in adverse health effects and skin irritation.	Personnel will fuel the equipment in a well-ventilated area, stand upwind while fueling, and minimize splash hazards so skin contact does not occur.
	Exposure to annular sealant material (e.g., bentonite and cement).	Sealing the annular space of wells.	Personnel could be exposed to annular sealant material via inhalation of material dust and/or direct skin/eye contact, which could result in personal injuries such as irritation of the	To prevent exposure, pour material slowly, stay upwind, and wear work gloves and safety glasses. If contact occurs, personnel will thoroughly wash the affected area with water and flush their eyes.



**SOP-GW-11;
GROUNDWATER MONITORING
WELL DESIGN AND
CONSTRUCTION**

**AUTHORIZED VERSION:
04/23/2018
PAGE 8 of 12**

CHEMICAL			respiratory system, skin, or eyes.	
NOISE	Elevated noise levels.	Drilling operations.	Personnel could be exposed to elevated noise levels when operating the drill and working near drilling operations resulting in hearing damage.	Personnel will wear hearing protection (e.g., ear plugs) when operating and working near the drill. Non-essential personnel will maintain a 20-foot buffer zone around the drill when possible. Hearing protection will be administered and used in accordance with the policies and procedures outlined in the Pioneer Corporate HASP.
ELECTRICAL	Contact with underground and/or overhead utilities.	Sites.	Injury, death or property damage could occur from equipment contact with underground and/or overhead utilities while drilling boreholes.	Personnel will follow the underground and overhead utilities procedures as outlined in the Pioneer Corporate HASP. Personnel will avoid areas with underground and overhead utilities hazards as much as possible.
BODY MECHANICS	Bending, squatting, and kneeling. Improper lifting.	During fieldwork activities. Sites.	Bending, squatting, and kneeling during fieldwork activities could result in muscle/back strains or other injuries. Back injuries and muscle/back strains could result when using improper techniques to lift and carry tools and equipment.	Personnel should stretch prior to starting work and they will take breaks when necessary. Personnel will use proper lifting techniques – get a good grip, keep the load close to the body, lift with legs and not with back, and avoid lifting loads above shoulder’s height. Two workers will lift/handle heavy items.



**SOP-GW-11;
GROUNDWATER MONITORING
WELL DESIGN AND
CONSTRUCTION**

**AUTHORIZED VERSION:
04/23/2018
PAGE 9 of 12**

GRAVITY	Falls from slips and trips.	Uneven terrain, slick/muddy/wet surfaces, and steep slopes.	Walking/working on slick/muddy/wet and uneven terrain could cause slips and trips resulting in falls and injuries.	Personnel will wear work boots with good traction and ankle support. They will plan their path and walk cautiously. If using bentonite as annular sealant, avoid bentonite contact with water on the ground. Pour the bentonite slowly to prevent spills and slippery surfaces.
WEATHER	Cold/heat stress. Lightning.	Outdoor sites. Outdoor sites.	Exposure to cold climates may result in cold burns, frostbite, and hypothermia. Exposure to high temperatures may result in heat cramps, heat exhaustion, or heat stroke. Electrocution, injury, death, or equipment damage could be caused by lightning strike.	Training on signs and symptoms of cold/heat stress is required. Personnel will wear appropriate clothing when working outdoors (e.g., layers and loose clothing). Personnel will remain hydrated and will have sufficient caloric intakes during the day. Personnel will follow procedures outlined in the applicable SSHASP and/or Pioneer Corporate HASP. Personnel will follow the 30/30 rule during lightning storms.
RADIATION	Ultraviolet (UV) radiation.	Outdoor sites.	Personnel could be exposed to UV radiation during summer months causing sun burns, skin damage, and eye damage.	Personnel will wear safety glasses with tinted lenses, long-sleeve work shirts, and long pants. Personnel should wear sunscreen, if necessary.
BIOLOGICAL	Plants, insects, and animals.	Outdoors.	Exposure to plants, insects, and/or animals may cause rashes, blisters, redness, and swelling.	Training on the signs and symptoms of exposure to plants, insects, and animals is required. Avoid contact with plants, insects, and animals. First aid kits will be available in company vehicles. Personnel with allergies will notify their supervisor.



**SOP-GW-11;
GROUNDWATER MONITORING
WELL DESIGN AND
CONSTRUCTION**

**AUTHORIZED VERSION:
04/23/2018
PAGE 10 of 12**

MECHANICAL	Pinch points.	During fieldwork activities.	Personnel could be exposed to pinch points when opening and closing gates, vehicle doors, carrying cases, and well caps or when using hand tools and equipment resulting in personal injuries such as scrapes, cuts, and broken fingers.	Personnel will be aware of finger/hand placement and not put fingers/hands between objects. Personnel will also wear work gloves to protect against pinch-point injuries and inspect all tools/equipment prior to each use.
	Rotating parts of the drill.	Drilling operations.	Inadvertent contact with rotating parts could result in fingers/hands becoming pinched or caught causing scrapes, cuts, and/or broken bones.	Personnel will avoid touching rotating parts of the drill. The drill operator and helpers will not wear loose clothing/jewelry. Personnel will know the location of all emergency shutoffs on the drill. Non-essential personnel will maintain a 20-foot buffer zone around the drill when possible.
PRESSURE	Pressurized hydraulic hoses.	Drilling operations.	Hydraulic hoses could burst/rupture resulting in inadvertent contact with hydraulic fluid or personal injury due to being struck by hoses.	The operator will inspect the drill and document inspections daily before starting work. The operator will also replace/repair all faulty equipment before starting work. When inspecting equipment, personnel will wear work gloves to prevent possible exposures to hydraulic fluids. Non-essential personnel will maintain a 20-foot buffer zone around the drill.
THERMAL	Hot surfaces.	Drilling operations.	The equipment components could become hot during drilling operations and direct contact	Personnel will avoid contact with hot surfaces, and they will wear work gloves as needed.



**SOP-GW-11;
GROUNDWATER MONITORING
WELL DESIGN AND
CONSTRUCTION**

**AUTHORIZED VERSION:
04/23/2018
PAGE 11 of 12**

			with these components could cause skin injuries.	
HUMAN FACTORS	Inexperienced and improperly trained worker.	Sites.	Inexperienced personnel and improper training could cause incidents resulting in adverse health effects and/or property damage.	Personnel will be properly trained in the procedure described above and other applicable procedures. Personnel will follow the stop work policy, if there are any issues.
SIMOPS	Not applicable.			

ADDITIONAL HSSE CONSIDERATIONS

This section to be completed with concurrence from the Safety and Health Manager.

REQUIRED PPE	Personal Protective Equipment (PPE): Hard hat, safety glasses, high-visibility work shirt or vest, long pants, work boots, nitrile gloves, and leather gloves.
APPLICABLE SDSs	Safety Data Sheets (SDSs) will be maintained based on the site characterization and contaminants.
REQUIRED PERMITS/ FORMS	Per site/project requirements.
ADDITIONAL TRAINING	Per site/project requirements.

DRAWINGS, DOCUMENTS, AND TOOLS/EQUIPMENT

The following documents should be referenced to assist in completing the associated task.

DRAWINGS	Map with site location and well locations.
RELATED SOPs/ PROCEDURES/ WORK PLANS	SOP-GW-12 Well Development Using a Modified Over-Pumping Technique.
TOOLS	Varies depending on selected drilling technique.
FORMS/ CHECKLIST	Field logbook and well installation log.



**SOP-GW-11;
GROUNDWATER MONITORING
WELL DESIGN AND
CONSTRUCTION**

**AUTHORIZED VERSION:
04/23/2018
PAGE 12 of 12**

APPROVALS/CONCURRENCE

By signing this document, all parties acknowledge the completeness and applicability of this SOP for its intended purpose. Also, by signing this document, it serves as acknowledgement that I have received training on the procedure and associated competency testing.

SOP TECHNICAL AUTHOR	DATE
Ken Manchester	04/23/2018
SAFETY AND HEALTH MANAGER	DATE
Tara Schleeman	04/23/2018



**SOP-GW-12;
WELL DEVELOPMENT USING
A MODIFIED OVER-PUMPING
TECHNIQUE**

**AUTHORIZED VERSION:
04/10/2018
PAGE 1 of 10**

PURPOSE	To provide standard instructions for well development and the removal of fine grained sediments from the vicinity of the well screen. Well development allows the water to flow freely from the formation into the well and reduces the turbidity of the water during groundwater sampling. Initial well development is critical to ensure that the well has the pumping volume required for future use.
SCOPE	<p>This practice is for the Pioneer Technical Services, Inc. (Pioneer) workforce and applies to work carried out by and on behalf of Pioneer. All members of the Pioneer workforce who conduct the work shall be trained and competent in the risk-assessed procedure described below.</p> <p>This Standard Operating Procedure (SOP) discusses well development using a modified over-pumping technique and can be used with the following pumps: peristaltic, low flow Grundfos, PROACTIVE 12-volt submersible, and Grundfos Redi-Flo II. Less vigorous methods of well development include bailers or manual surge blocks. These methods are addressed in other SOPs. If a well requires more vigorous development than over-pumping (e.g., soil types, chemicals used during installation, large required production volumes, etc.), a well installer or subcontractor may be required to complete the development.</p>

WORK INSTRUCTIONS

The following instructions are intended to provide sufficient guidance to perform the task in a safe, accurate, and reliable manner. Should these instructions present information that is inaccurate or unsafe, operations personnel must bring the issue to the attention of the Project Manager and the appropriate revisions made. All work performed under this Standard Operating Procedure (SOP) will be consistent with procedures and policies described in the appropriate Operation, Maintenance, and Monitoring (O&M) Plan (where applicable), appropriate Site-Specific Health and Safety Plan (SSHASP), and Pioneer Corporate Health and Safety Plan (HASP).

TASK	INSTRUCTIONS
1. Select pump.	The table below summarizes the types of pumps Pioneer has readily available for well development. Personnel should select the appropriate pump for the well development required using the table below.



**SOP-GW-12;
WELL DEVELOPMENT USING
A MODIFIED OVER-PUMPING
TECHNIQUE**

**AUTHORIZED VERSION:
04/10/2018
PAGE 2 of 10**

	<table border="1" style="width: 100%; border-collapse: collapse;"> <thead> <tr> <th style="width: 25%;">Pump/ Development Type</th> <th style="width: 25%;">Well Diameter (inches)</th> <th style="width: 25%;">Max Well Depth (ft)</th> <th style="width: 25%;">Anticipated Production</th> </tr> </thead> <tbody> <tr> <td rowspan="2">Bailer¹</td> <td style="text-align: center;">1</td> <td style="text-align: center;">100</td> <td>Poor to Good</td> </tr> <tr> <td style="text-align: center;">≥2</td> <td style="text-align: center;">100</td> <td>Poor</td> </tr> <tr> <td rowspan="2">Manual Surge Block¹</td> <td style="text-align: center;">1</td> <td style="text-align: center;">100</td> <td>Poor to Good</td> </tr> <tr> <td style="text-align: center;">≥2</td> <td style="text-align: center;">100</td> <td>Poor</td> </tr> <tr> <td rowspan="2">Peristaltic Pump</td> <td style="text-align: center;">1</td> <td style="text-align: center;">25</td> <td>Poor to Good</td> </tr> <tr> <td style="text-align: center;">2</td> <td style="text-align: center;">25</td> <td>Poor</td> </tr> <tr> <td>Low Flow Grundfos</td> <td style="text-align: center;">≥2</td> <td style="text-align: center;">200</td> <td>Poor to Good</td> </tr> <tr> <td>PROACTIVE 12- volt Submersible Pump</td> <td style="text-align: center;">≥2</td> <td style="text-align: center;">80</td> <td>Good</td> </tr> <tr> <td>Grundfos Redi-Flo II</td> <td style="text-align: center;">≥2</td> <td style="text-align: center;">250</td> <td>Good</td> </tr> <tr> <td>Subcontractor/Well Installer</td> <td style="text-align: center;">≥2</td> <td style="text-align: center;">>250</td> <td>Poor to Good</td> </tr> </tbody> </table> <p style="font-size: small; margin-top: 5px;">1. If a bailer or manual surge block is the only alternative, the modified over-pumping technique cannot be used. Instead, personnel should follow the appropriate, alternative SOP.</p>	Pump/ Development Type	Well Diameter (inches)	Max Well Depth (ft)	Anticipated Production	Bailer ¹	1	100	Poor to Good	≥2	100	Poor	Manual Surge Block ¹	1	100	Poor to Good	≥2	100	Poor	Peristaltic Pump	1	25	Poor to Good	2	25	Poor	Low Flow Grundfos	≥2	200	Poor to Good	PROACTIVE 12- volt Submersible Pump	≥2	80	Good	Grundfos Redi-Flo II	≥2	250	Good	Subcontractor/Well Installer	≥2	>250	Poor to Good
Pump/ Development Type	Well Diameter (inches)	Max Well Depth (ft)	Anticipated Production																																							
Bailer ¹	1	100	Poor to Good																																							
	≥2	100	Poor																																							
Manual Surge Block ¹	1	100	Poor to Good																																							
	≥2	100	Poor																																							
Peristaltic Pump	1	25	Poor to Good																																							
	2	25	Poor																																							
Low Flow Grundfos	≥2	200	Poor to Good																																							
PROACTIVE 12- volt Submersible Pump	≥2	80	Good																																							
Grundfos Redi-Flo II	≥2	250	Good																																							
Subcontractor/Well Installer	≥2	>250	Poor to Good																																							
2. Gather information.	Review the Site Sampling and Analysis Plan (SAP) or Work Plan for purge water containment requirements. Compile the necessary equipment and well installation information (e.g., total depth, screen interval, etc.) prior to traveling to the site.																																									
3. Set up equipment.	Upon arrival at the well/piezometer to be developed, place the containers that will be used to contain purge water (if required) in an accessible location. Set up the remainder of the equipment adjacent to the well, within spill containment if required.																																									
4. Take and initial DTW reading.	Open the well/piezometer and take an initial depth to water (DTW) reading following the instructions outlined in SOP-GW-03 Depth to Water Level Measurements. Record the initial DTW in the field logbook and on the well development field data sheet.																																									
5. Check the total depth of the well.	Check the total depth of the well by turning off the buzzer on the DTW meter and lowering probe to the bottom of the well. Record this information in the field logbook and on the well development field data sheet. Remove the DTW probe from the well. Record the screen depth and length (available from the well installation log).																																									
6. Set up pump and tubing.	If needed, attach an appropriate length of disposable or decontaminated tubing to the pump outlet or put tubing in the pump head. Don a new, clean pair of gloves prior to handling the tubing. Lower pump or tubing into the well. The pump intake should be located near the bottom of the screened interval. If the screen extends to the bottom of the well, make sure the intake for the pump is located above any slurry that may be present in the bottom of the well, approximately 1/2 to 1 foot above the bottom if using the submersible pumps.																																									



**SOP-GW-12;
WELL DEVELOPMENT USING
A MODIFIED OVER-PUMPING
TECHNIQUE**

AUTHORIZED VERSION:
04/10/2018
PAGE 3 of 10

	<p>If using a peristaltic pump, tubing can be located closer to the bottom of the well as slurry will only clog the tubing and not damage the pump itself.</p> <p>If using a submersible 12-volt pump without a controller, put a valve on the discharge end of tubing and securely fasten.</p> <p>Record the depth of the pump intake in the field logbook and on the well development field data sheet.</p>
<p>7. Measure DTW with the pump installed.</p>	<p>Put the DTW probe back in the well and make sure it is turned on. Record the DTW with the pump installed.</p>
<p>8. Turn the pump on and adjust water flow.</p>	<p>If using a 12-volt submersible pump, start the pump with the attached discharge valve all the way open. If using a Grundfos pump with a controller or a peristaltic pump, turn the pump on and raise the pumping rate slowly until water starts to flow.</p> <p>Monitor the DTW meter; the water elevation should drop until the tubing is full and water is flowing freely. If the water elevation continues to drop after water is flowing smoothly, turn flow down using either the discharge valve or the controller until the water elevation stabilizes.</p> <p>Record the time development starts, the stabilized water elevation, and an estimate of volume purged in the field logbook and on the well development field data sheet as “Initial Drawdown.”</p>
<p>9. Measure the stabilized water flow rate.</p>	<p>Measure the stabilized water flow rate using an appropriately-sized container (e.g., graduated cylinder, marked beaker, marked bucket, etc.) and a stopwatch to determine the volume of water per minute being purged from the well. Record the water flow rate in the field logbook and on the well development field data sheet.</p>
<p>10. Record the characteristics of the purged water.</p>	<p>Record the color of water, presence of sand or silt, and any odors or sheen. If the water is not extremely dirty, run an initial turbidity measurement and record.</p>
<p>11. Track the volume of water being removed.</p>	<p>Track the volume of water being removed. Volume may be calculated by either multiplying the elapsed time by the water flow rate or multiplying the number of buckets/drums purged by the volume of the bucket/drum. Keep a record of time, water removed, turbidity measurements and DTW readings in the field logbook and on the well development field data sheet.</p>
<p>12. Measure and record the field parameters.</p>	<p>Once the water appears to be clear, begin measuring field parameters. At a minimum, measure temperature, pH, specific conductivity (SC), and turbidity. If required by the SAP or Work Plan, measure and record the oxidation reduction potential (ORP) and dissolved oxygen (DO).</p> <p>Depending on the water flow rate field parameter probes can be placed in a 5-gallon bucket, in a ½- to 1-liter beaker or in a flow thru cell. Turnover of water in the container should be quick (e.g., 1 to 2 minutes). As an example, if the water is purging</p>



**SOP-GW-12;
WELL DEVELOPMENT USING
A MODIFIED OVER-PUMPING
TECHNIQUE**

**AUTHORIZED VERSION:
04/10/2018
PAGE 4 of 10**

	<p>at 4 gallons a minute, a 5-gallon bucket could be used, as turnover in the bucket would be about 1 minute. If water is purging at 1 to 2 gallons a minute, a liter beaker may be more appropriate. If the water is fairly clear, a flow through cell with appropriately sized bypass tubing can be used with any flow rate. The flow through cell allows the water in the bypass tubing to be discharged directly into a storage container or to the ground a safe distance downgradient from the well.</p> <p>Record parameter measurements every 5 to 10 minutes. Record DTW measurements and estimated volume along with the parameter readings in the field logbook and/or on the well development field data sheet.</p>
<p>13. Purge the well and monitor drawdown.</p>	<p>If possible, when turbidity falls below 50 Nephelometric Turbidity Unit (NTU), increase the flow by adjusting the discharge valve or turning up the controller. Purge the well at about twice the stabilized water flow rate determined in Steps 8 and 9. Monitor drawdown constantly as you do not want to purge the well dry.</p> <ul style="list-style-type: none"> • The water elevation may stabilize at a level lower than the initial DTW reading. If so, record how long it took to stabilize at the lower level, the amount of water purged, and the new DTW elevation in the field logbook and on the well development field data sheet. • If the water elevation in the well drops to about 4 to 5 feet above the pump intake (the acceptable drawdown elevation should be adjusted based on the water column, screen length and depth of the well being developed; ideally you want to develop the well along the entire screen length), turn the discharge valve or controller below the starting flow rate and allow the well to “recover.” Record the duration, amount purged, and DTW when done with the initial over-pumping of the well. • If the pump is purging at maximum capacity, or if no drawdown occurs at a higher flow, turn the pump off, let the well “recover” for 1 to 5 minutes, and turn the pump back on. Record the duration of the stoppage and the new starting water level in the field logbook and on the well development field data sheet.
<p>14. Continue monitoring turbidity and recording field parameters.</p>	<p>Turbidity may increase after the over-pumping or stopping. Continue recording field parameters unless the turbidity exceeds 1000 NTU. At this point, remove the field parameter probes and wait for the water to clear up before recording field parameters. Note this in the field logbook or on the well development field data sheet.</p> <p>Once turbidity measures less than 50 NTU, repeat Steps 12 and 13 until the clarity of water does not change significantly between lower and higher flows.</p>
<p>15. Adjust pump as needed.</p>	<p>If time permits (as designated in the SAP or Work plan) and the stabilized water level allows, raise the pump to the midpoint of the screen and repeat Steps 12 through 14, recording time, field parameters, volume purged, and DTW readings until turbidity readings are less than 50 NTU.</p>
<p>16. Continue monitoring turbidity and</p>	<p>The well is considered developed when 3 consecutive readings for turbidity are below the SAP or Work Plan designated requirements (e.g., the Clark Fork River Superfund Site Investigation SOP [ARCO, 1992] requires readings below 5 NTU, and the U.S.</p>



**SOP-GW-12;
WELL DEVELOPMENT USING
A MODIFIED OVER-PUMPING
TECHNIQUE**

**AUTHORIZED VERSION:
04/10/2018
PAGE 5 of 10**

field parameters to determine if the well is developed.	Environmental Protection Agency [EPA] well development protocol requires readings below 50 NTU) and the remaining required field parameters have stabilized. Water quality parameters are considered stable when three consecutive readings are as follows: <ul style="list-style-type: none">• Temperature range is no more than +/- 1 degree Celsius (°C);• pH varies by no more than 0.1 pH units; and• SC readings are within 3% of the average.
17. Record the final DTW and calculate the total amount of water purged.	Before turning off the pump, record a final DTW. Calculate the total amount of water purged and record the volume in the field logbook and on the well development field data sheet.
18. Dispose of the purge water and tubing.	Dispose of the purge water and tubing as outlined in the SAP or Work Plan.



HSSE CONSIDERATIONS

This section to be completed with concurrence from the Safety and Health Manager.

<i>SOURCE</i>	<i>HAZARDS</i>	<i>WHERE</i>	<i>HOW, WHEN, RESULT</i>	<i>CONTROLS</i>
CHEMICAL	Potential contact with contaminated soils and water.	During well development.	Inadvertent exposure to contaminated soils and water could lead to adverse health effects.	Personnel will practice proper personal hygiene – wash hands prior to eating/drinking and when leaving the site. Personnel will wear nitrile gloves and safety glasses when contact with purge water is possible. Pour purge water from buckets into disposal area/containers used to contain purge water slowly to prevent splashes and skin contact. Keep control of high-flow discharge hoses to prevent water spraying and skin contact.
	Carbon monoxide (CO).	Generator.	Potential exposure to CO when working around the generator could result in irritated eyes, headache, nausea, weakness, and dizziness.	Personnel will stay up wind when working around the generator. The generator will not be operated indoors or near openings to any buildings that might be occupied.
	Contact with gasoline.	Fueling the generator.	Inadvertent exposure via inhalation and/or skin contact can result in adverse health effects and skin irritation if contact with gasoline occurs.	Personnel will fuel the generator in a well-ventilated area, stand up wind while fueling, and minimize splash hazards so skin contact does not occur. Wear nitrile gloves when removing the fuel cap and filter.



**SOP-GW-12;
WELL DEVELOPMENT USING
A MODIFIED OVER-PUMPING
TECHNIQUE**

**AUTHORIZED VERSION:
04/10/2018
PAGE 8 of 10**

HSSE CONSIDERATIONS				
This section to be completed with concurrence from the Safety and Health Manager.				
BODY MECHANICS	Improper lifting.	During well development.	Back injuries and muscle/back strains could result when using improper techniques to lift and carry tools and equipment.	Personnel will use proper lifting techniques – get a good grip, keep the load close to the body, lift with legs and not with back, and avoid lifting loads above shoulder’s height. Two workers will lift/handle heavy items.
	Bending, squatting, and kneeling.	During well development.	Bending, squatting, and kneeling during work activities could result in muscle/back strains or other injuries.	Personnel should stretch prior to starting work and they will take breaks when necessary.
GRAVITY	Falls from slips and trips.	Uneven terrain, slick/muddy/wet surfaces and steep slopes.	Walking/working on slick/muddy/wet and uneven terrain could cause slips and trips resulting in falls and injuries.	Personnel will wear work boots with good traction and ankle support. Personnel will be aware of walking/working surfaces and choose a path to avoid hazards. Keep work areas as dry as possible. If conditions are wet or muddy, wear muck boots.
WEATHER	Cold/heat stress.	Outdoor sites.	Exposure to cold climates may result in cold burns, frostbite, and hypothermia. Exposure to high temperatures may result in heat cramps, heat exhaustion, or heat stroke.	Training on signs and symptoms of cold/heat stress is required. Personnel will wear appropriate clothing when working outdoors. Personnel will remain hydrated and will have sufficient caloric intakes during the day. Personnel will follow procedures outlined in applicable SSHASP and/or Pioneer corporate HASP.
	Lightning.	Outdoor sites.	Electrocution, injury, death, or equipment damage could result from lightning strike.	Personnel will follow the 30/30 rule during lightning storms.



**SOP-GW-12;
WELL DEVELOPMENT USING
A MODIFIED OVER-PUMPING
TECHNIQUE**

**AUTHORIZED VERSION:
04/10/2018
PAGE 9 of 10**

HSSE CONSIDERATIONS				
This section to be completed with concurrence from the Safety and Health Manager.				
RADIATION	Ultraviolet (UV) radiation.	Outdoor sites.	Personnel could be exposed to UV radiation during summer months causing sun burns, skin damage, and eye damage.	Personnel will wear safety glasses with tinted lenses, long-sleeve work shirts, and long pants. Personnel should wear sunscreen, if necessary.
BIOLOGICAL	Plants, insects, and animals.	Outdoors.	Exposure to plants, insects, and/or animals may cause rashes, blisters, redness, and swelling.	Training on the signs and symptoms of exposure to plants, insects, and animals is required. Avoid contact with plants, insects, and animals. First-aid kits will be available on the site. Personnel with allergies will notify their supervisor.
MECHANICAL	Pinch points.	Well caps.	Personal injury could result from fingers getting pinched in well caps.	Personnel will wear leather gloves when removing well caps.
PRESSURE	Not applicable.			
THERMAL	Not applicable.			
HUMAN FACTORS	Inexperienced and improperly trained personnel.	Sites.	Inexperienced personnel and improper training could cause incidents resulting in adverse health effects and/or property damage.	Personnel will be properly trained in the procedure described above and other applicable procedures. Personnel will follow the stop work policy, if there are any issues.
SIMOPS	Not applicable.			





**SOP-GW-12;
WELL DEVELOPMENT USING
A MODIFIED OVER-PUMPING
TECHNIQUE**

AUTHORIZED VERSION:
04/10/2018
PAGE 10 of 10

HSSE CONSIDERATIONS	
This section to be completed with concurrence from the Safety and Health Manager.	
ADDITIONAL HSSE CONSIDERATIONS	
This section to be completed with concurrence from the Safety and Health Manager.	
REQUIRED PPE	Personal Protective Equipment (PPE): Hard hat, safety glasses, high-visibility work shirt or vest, long pants, work boots, nitrile gloves, and work gloves.
APPLICABLE SDS	Safety Data Sheets (SDSs) will be maintained based on the site characterization and contaminants.
REQUIRED PERMITS/FORMS	Per site/project requirements.
ADDITIONAL TRAINING	Per site/project requirements.

DRAWINGS, DOCUMENTS, AND TOOLS/EQUIPMENT	
The following documents should be referenced to assist in completing the associated task.	
DRAWINGS	
RELATED SOPs/PROCEDURES/WORK PLANS	SOP-GW-03 Depth to Water Level Measurements
TOOLS	DTW meter, pump and tubing (see step 1 for pump selection), turbidity meter, container to measure water flow rate (e.g., graduated cylinder, marked beaker, marked bucket, etc.), stopwatch, field parameter meters, and containers to contain purge water (if required).
FORMS/CHECKLIST	Field logbook, well development field data sheet, and well installation log.

APPROVALS/CONCURRENCE	
By signing this document, all parties acknowledge the completeness and applicability of this SOP for its intended purpose. Also, by signing this document, it serves as acknowledgement that I have received training on the procedure and associated competency testing.	
SOP TECHNICAL AUTHOR	DATE
 Julie Flammang	04/10/2018
SAFETY AND HEALTH MANAGER	DATE
 Tara Schleeman	04/10/2018



SOP-GW-14
FIELD WATER QUALITY
MEASUREMENTS
USING THE GEOTECH MULTI-PROBE
FLOWBLOCK FLOW THROUGH DEVICE

DATE ISSUED:
05/22/2015
REVISION: 0
PAGE 1 of 10

PURPOSE	To provide standard instructions for setting up Geotech Multi-Probe Flowblock (Geotech Flowblock) flow through device for measuring field water quality parameters.
SCOPE	This practice has been prepared for the Pioneer Technical Services, Inc. (Pioneer) workforce and applies to work carried out by and on behalf of Pioneer. All members of the Pioneer workforce who conduct the work shall be trained and competent in the risk-assessed work described below.

WORK INSTRUCTIONS

The following instructions are intended to provide sufficient guidance to perform the task in a safe, accurate, and reliable manner. Should these instructions present information that is inaccurate or unsafe, operations personnel must bring the issue to the attention of the Project Manager and the appropriate revisions made. All work carried under this SOP will be consistent with procedures and policies described in the appropriate Operation, Maintenance, and Monitoring (O&M) Plan (where applicable), appropriate Site-Specific Health and Safety Plan (SSHASP), and Pioneer Corporate Health and Safety Plan (HASP).

TASK	INSTRUCTIONS
Notes	<p>The Geotech Flowblock flow through device can be used directly in-line with most groundwater pumping systems such as the Grundfos RediFlo2™, Geotech SS Geosub, Geotech Bladder Pump, or Geopump Peristaltic Pump, and equivalent pumps. The Geotech Flowblock is designed for minimal sample volume (low-flow sampling) to reduce stirring dependence of sensors. The flowrate can vary from 100 mL/min to 1 gpm (3.8 L/min).</p> <p>No laboratory samples will be taken from water that has flowed through the Geotech Flowblock or the quick-connect barbs. Samples will be collected from tubing that was cut before contact with the Geotech Flowblock or the quick-connect barbs.</p> <p>The Geotech Flowblock does not need to be decontaminated between samples as it will not be in contact with laboratory samples. The Geotech Flowblock should be flushed between sample sites with tap or deionized (DI) water to flush out accumulated sediment.</p> <p>Refer to the following SOPs for the sampling setup in which the Geotech Flowblock will be used:</p> <p>SOP-GW-02 Sampling with A Bailer SOP-GW-10 Purging And Sampling with A 12-Volt Submersible Pump SOP-GW-10A Purging And Sampling with A Low Flow Submersible Pump SOP-GW-10B Purging And Sampling with Grunfoss Redi-Flow Submersible Pump SOP-GW-10C Purging And Sampling with A Peristaltic Pump SOP-GW-13 Sampling Groundwater From A Tap</p>



SOP-GW-14
FIELD WATER QUALITY
MEASUREMENTS
USING THE GEOTECH MULTI-PROBE
FLOWBLOCK FLOW THROUGH DEVICE

DATE ISSUED:
05/22/2015
REVISION: 0
PAGE 2 of 10

	<p>Prior to using the Geotech Flowblock, pH, specific conductivity, oxidation reduction potential (ORP), and dissolved oxygen (DO) field parameter meters need to be calibrated per the following SOPs:</p> <p>SOP-WFM-01 Field Measurement of pH In Water SOP-WFM-02 Field Measurement of Oxygen Reduction Potential in Water SOP-WFM-03 Field Measurement of Specific Conductance SOP-WFM-04 Field Measurement of Water Temperature SOP-WFM-07 Field Measurement of Dissolved Oxygen</p>
<p>1. (Option 1) Set up Geotech Flowblock.</p>	<p>The Option 1 set up is shown in Figure 1 below. This option can be used when using a pump that can be adjusted to a very low flow, such as the peristaltic pump and the low flow submersible pump.</p> <ol style="list-style-type: none">1. Cut a piece of new silicon tubing. Use this tubing to connect the connecting valve to the Geotech Flowblock. Use a hose clamp to attach the tubing to the connecting valve. A hose clamp may also be needed to attach the tubing to the Geotech Flowblock.2. Attach pump tubing to the connecting valve with a hose clamp.3. Insert probes in the appropriate grommets in the Geotech Flowblock as depicted on Figure 1. Loosen the grommet to insert probes. The black cap on the pH and ORP columns (the center 2 grommets) may need to be removed to get the probes inserted. Make sure that the gasket present on each column stays on either the probe or in the block. Push the probes to bottom of each column and slightly tighten the black caps on the grommets.4. Start pump and raise each probe to release pressure and get the associated column to fill. Once it is full, tighten the black cap on the grommets and move to the next probe (moving from inlet to outlet). If the columns are not filling, cover the end of the outlet discharge tubing and tighten the grommets as each column fills. No air bubbles should be present in the columns. If an air bubble is present loosen the grommet, raise the probe, wait for the bubble to disperse and lower the probe and retighten the grommets. Adjust flow using pump controls so that water is not spurting out of block.5. The pump speed may need to be adjusted during purging as the reduction of head may require adjustment of flow through the Geotech Flowblock.

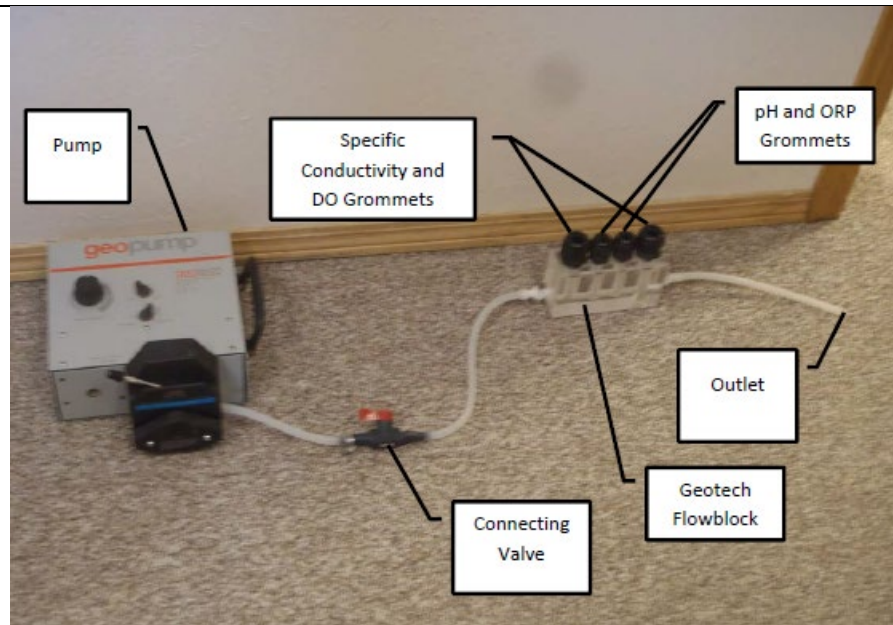

Figure 1. Geotech Flowblock

1. (Option 2) Set up Geotech Flowblock with relief valve port.

Note: The relief valve port will be used if flow is greater than the Geotech Flowblock can handle and to collect turbidity samples for field measurement.

The Option 2 set up is shown in Figure 2 below. This set up should be used for pumping situations where flow cannot be adjusted low enough that all water can flow through the Geotech Flowblock.

1. Cut one piece of silicon tubing to connect the relief valve to the Geotech Flowblock. Use a hose clamp and attach tubing to the outlet directly across from the input on the relief valve. Using a hose clamp attach the other end of the tubing to the Geotech Flowblock.
2. Attach pump tubing to the inlet on the relief valve with a hose clamp.
3. Cut (2) 18-inch pieces of silicon tubing to handle discharge.
4. Attach one piece of this tubing to the other outlet on the relief valve. This will provide a way to discharge water that cannot flow through the Geotech Flowblock. Laboratory samples will not be collected from the relief valve, however water for field turbidity measurements will be collected from this valve.
5. The second piece of silicon tubing will be attached to the outlet side of the Geotech Flowblock. This silicon tubing needs to be long enough to discharge to the bucket or container that is being used to measure volume.

6. Insert probes in the appropriate grommets in the Geotech Flowblock as depicted on Figure 2. Loosen the grommet to insert a probe. The black cap on the pH and ORP columns (the center 2 grommets) may need to be removed to get the probes inserted. Make sure that the gasket present on each column stays on either the probe or in the block. Push the probes to bottom of each column and slightly tighten the black caps on the grommets.
7. Start pump and raise each probe to release pressure and get the associated column to fill. Once it is full, tighten the black cap on the grommets and move to the next probe (moving from inlet to outlet). If the columns are not filling, cover the end of the outlet discharge tubing and tighten the grommets as each column fills. No air bubbles should be present in the columns. If an air bubble is present loosen the grommet, raise the probe, wait for the bubble to disperse and lower the probe and retighten the grommets. Adjust flow using pump controls and the relief valve so that water is not spurting out of block.
8. The pump and or relief valve port may need to be adjusted during purging, as the reduction of head may require the adjustment of flow through the Geotech Flowblock.

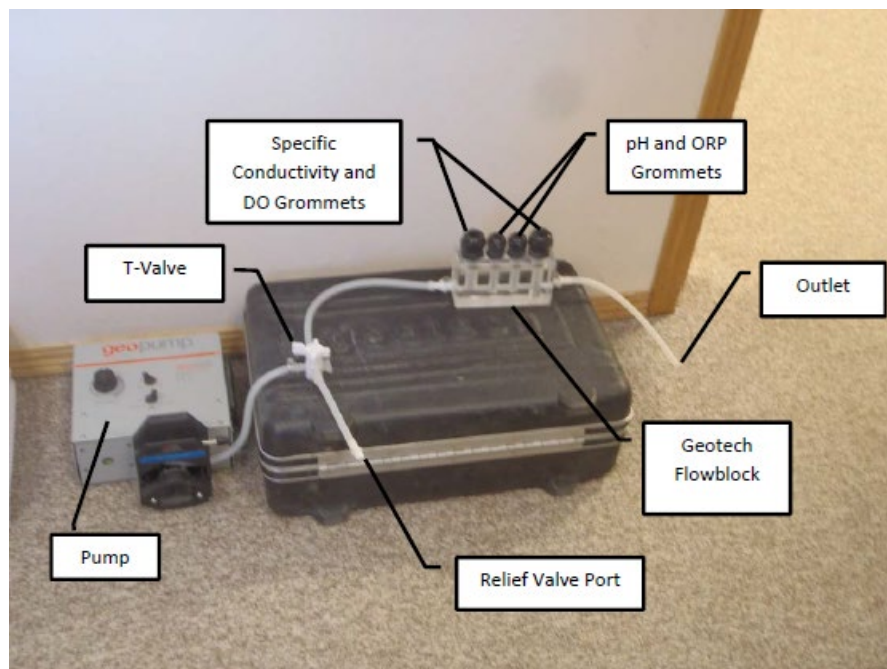

Figure 2. Geotech Flowblock with Relief Valve Port

2. Monitor and record field parameters and depth to

Adjust pumping rate as needed to maintain a minimal drawdown of <math><0.1\text{ m}</math> (<math><4\text{ inches}</math>). Time, flowrate and drawdown should be recorded in the logbook or on field data sheets.

During well purging, monitor field parameters including pH, conductivity, and



SOP-GW-14
FIELD WATER QUALITY
MEASUREMENTS
USING THE GEOTECH MULTI-PROBE
FLOWBLOCK FLOW THROUGH DEVICE

DATE ISSUED:
05/22/2015
REVISION: 0
PAGE 5 of 10

<p>water level measurements.</p>	<p>temperature. The SAP or work plan may indicate other field parameters that need to be monitored, such as ORP (eH), DO, and turbidity. As outlined in the 2018 Groundwater Sampling Guidance from the Montana Department of Environmental Quality – Contaminated Site Cleanup Bureau, water quality parameters will be considered stable when three consecutive readings (generally 2-5 minutes apart) are as follows:</p> <ol style="list-style-type: none"> a. Temperature range is no more than +/- 1 degree Celsius (°C); b. pH varies by no more than 0.1 pH units; c. Specific conductivity readings are within 3% of the average; d. ORP varies by no more than 10 mV units; e. DO readings are within 10% of the average; and f. Turbidity readings are within 10% of the average. <p>Field parameters should be recorded in the logbook or on field data sheets.</p>
<p>3. Collect samples.</p>	<p>Purge until water quality parameters stabilize. Once these conditions occur, sampling can commence by following SOP-SA-02 Sample Preservation and Containerization for Aqueous Samples. Cut the tubing just above the Connector Valve or Relief Valve and collect the samples directly from the tubing.</p> <p>In general, volatile organic compound (VOC) samples should not be collected when using a peristaltic pump. If VOC analysis is required, collect the VOC samples first by filling pre-preserved sample containers. Fill the sample containers by allowing pump discharge to flow gently down the side of the bottle with minimal entry turbulence. Double check for bubbles as this method tends to produce them. Cap each bottle as filled.</p> <p>To check for air bubbles: turn the VOC bottle upside down, tap lightly, turn right side up, see if any bubbles float to the top. If you see a bubble, remove lid, add additional water, and reseal.</p> <p>If a filtered sample is required, an in-line high capacity (0.45 µm) should be inserted into the discharge end of the tubing after the other sample containers are filled. Fill the sample bottle and preserve immediately; cap the bottle.</p>
<p>4. Label, store, and ship samples.</p>	<p>Label the sample bottle as appropriate and place in a cooler. Ship with other samples in accordance with SOP-SA-01 Soil and Water Sample Packaging and Shipping.</p>
<p>5. Dispose of used tubing.</p>	<p>Tubing used in the well sampling will be disposed of in accordance with SOP-DE-03 Investigation Derived Waste Handling.</p>



SOP-GW-14
FIELD WATER QUALITY
MEASUREMENTS
USING THE GEOTECH MULTI-PROBE
FLOWBLOCK FLOW THROUGH DEVICE

DATE ISSUED:
05/22/2015
REVISION: 0
PAGE 6 of 10

HSSE CONSIDERATIONS				
This section to be completed with concurrence from the Safety and Health Manager.				
<i>SOURCE</i>	<i>HAZARDS</i>	<i>WHERE</i>	<i>HOW, WHEN, RESULT</i>	<i>CONTROLS</i>
CHEMICAL	Potential contact with contaminated water.	Sites.	Inadvertent exposure to contaminated water could lead to adverse health effects.	Personnel will practice proper personal hygiene – wash hands prior to eating/drinking and when leaving the site. Employees will wear nitrile gloves and safety glasses when taking field measurements, collecting, and handling samples.
	Potential contact with field parameter buffer solutions.	Equipment calibration.	Inadvertent exposure to field parameter buffer solutions could lead to adverse health effects (e.g., irritation of eye, skin, and/or respiratory tract).	Personnel will practice proper personal hygiene – wash hands prior to eating and after calibrating equipment. Employees will wear nitrile gloves and safety glasses when handling field parameter buffer solutions.
	Preservatives (HCL, HNO ₃ , H ₂ SO ₄ , NaOH and Na ₂ S ₂ O ₃).	In bottles or added to bottles through sampling process.	Inadvertent exposure to preservatives could lead to adverse health effects.	Safety Data Sheets for each preservative chemical are available to all employees on the Pioneer company web site. Personnel will wear nitrile gloves and safety glasses when adding preservatives to samples bottles. Refer to the Chemical Flushing Guidelines available inside vehicle's first aid kit for first-aid procedures in case of contact with preservatives.
NOISE	Not applicable.			
ELECTRICAL	Not applicable.			
BODY MECHANICS	Bending, squatting, and kneeling.	During measurements.	Bending, squatting, and kneeling during	Employees should stretch prior to starting work and they will take breaks when necessary.



SOP-GW-14
FIELD WATER QUALITY
MEASUREMENTS
USING THE GEOTECH MULTI-PROBE
FLOWBLOCK FLOW THROUGH DEVICE

DATE ISSUED:
05/22/2015
REVISION: 0
PAGE 7 of 10

			field parameter measurements could result in muscle/back strains or other injuries.	
GRAVITY	Falls from slips and trips.	Uneven terrain, slick/muddy/wet surfaces and steep slopes.	Walking/working on slick/muddy/wet and uneven terrain could cause slips and trips resulting in falls and injuries.	Workers will wear work boots with good traction and ankle support. Personnel will be aware of working/walking surfaces and choose a path to avoid hazards. Keep work areas as dry as possible. Wear muck boots, as necessary.
WEATHER	Cold/heat stress.	Sites.	Exposure to cold climates may result in cold burns, frostbites, and hypothermia. Exposure to high temperatures may result in heat cramps, heat exhaustion, or heat stroke.	Training on signs and symptoms of cold/heat stress is required. Personnel will wear appropriate clothing when working outdoors. Employees will remain hydrated and will have sufficient caloric intakes during the day. Personnel will follow procedures outlined in applicable SSHASP and/or Pioneer corporate HASP.
	Hypothermia/frostbite.	Sites where air temperature is 35.6°F (2°C) or less.	Workers who become immersed in water or whose clothing becomes wet may be exposed to hypothermia and/or frostbite.	Employees will change clothing if it becomes wet. When applicable, employees will wear waders to prevent clothing from getting wet.
	Lightning.	Outdoor sites.	Electrocution, injury, death, or equipment damage could be caused by lightning strike.	Employees will follow the 30/30 rule during lightning storms.



SOP-GW-14
FIELD WATER QUALITY
MEASUREMENTS
USING THE GEOTECH MULTI-PROBE
FLOWBLOCK FLOW THROUGH DEVICE

DATE ISSUED:
05/22/2015
REVISION: 0
PAGE 8 of 10

RADIATION	Ultraviolet (UV) radiation.	Outdoors.	Employees could be exposed to UV radiation during summer months causing sun burns, skin damage, and eye damage.	Employees will wear safety glasses with tinted lenses, long-sleeve work shirts, and long pants. Employees should wear sunscreen, if necessary.
BIOLOGICAL	Plants, insects, and animals.	Sites.	Exposure to plants, insects, and/or animals may cause rashes, blisters, redness, and swelling.	Training on the signs and symptoms of exposure to plants, insects, and animals is required. Avoid contact with plants, insects, and animals. First-aid kits will be available on site. Employees with allergies will notify their supervisor.
MECHANICAL	Pinch points and scrapes. Scrapes.	Well caps. Attaching hose clamps.	Personal injury could result from fingers getting pinched when opening/closing well caps. Personal injury could result when attaching hose clamps with a screwdriver resulting in hand scrapes.	Employees will wear work gloves when opening/closing well caps. Personnel will use a nut driver, if available. Personnel will be cautious when attaching hose clamps and will wear work gloves.
PRESSURE	Not applicable.			
THERMAL	Not applicable.			
HUMAN FACTORS	Inexperienced and improperly trained worker.	Sites.	Inexperienced workers and improper training could cause incidents resulting in adverse health	Employees will be properly trained in this procedure and other applicable procedures. Employees will implement stop work procedures, if necessary.



SOP-GW-14
FIELD WATER QUALITY
MEASUREMENTS
USING THE GEOTECH MULTI-PROBE
FLOWBLOCK FLOW THROUGH DEVICE

DATE ISSUED:
05/22/2015
REVISION: 0
PAGE 9 of 10

			effects and/or property damage.	
SIMOPS	Not applicable.			
ADDITIONAL HSSE CONSIDERATIONS				
This section to be completed with concurrence from the Safety and Health Manager.				
REQUIRED PPE	Hard hat, safety glasses, high-visibility work shirt or vest, long pants, work boots, nitrile gloves, and work gloves.			
APPLICABLE SDS	HCL; HNO ₃ ; H ₂ SO ₄ ; NaOH; Na ₂ S ₂ O ₃ ; ORP; electrode storage solution; specific conductivity solution; pH and ORP electrode cleaner solution; pH 4, pH 7, and pH 10 buffer solutions. Additional Safety Data Sheets (SDSs) will be maintained based on site characterization and contaminants.			
REQUIRED PERMITS/FORMS	Per site/project requirements.			
ADDITIONAL TRAINING	Per site/project requirements.			



DRAWINGS, DOCUMENTS, AND TOOLS/EQUIPMENT	
The following documents should be referenced to assist in completing the associated task.	
DRAWINGS	Map with site location and sample locations.
RELATED SOPs/PROCEDURES/WORK PLANS	SOP-GW-02 Sampling with A Bailer SOP-GW-10 Purging And Sampling with A 12-Volt Submersible Pump SOP-GW-10A Purging And Sampling with A Low Flow Submersible Pump SOP-GW-10B Purging And Sampling with Grunfoss Redi-Flow Submersible Pump SOP-GW-10C Purging And Sampling with A Peristaltic Pump SOP-GW-13 Sampling Groundwater From A Tap SOP-WFM-01 Field Measurement of pH In Water SOP-WFM-02 Field Measurement of Oxygen Reduction Potential in Water SOP-WFM-03 Field Measurement of Specific Conductance SOP-WFM-04 Field Measurement of Water Temperature SOP-WFM-07 Field Measurement of Dissolved Oxygen SOP-SA-02 Sample Preservation and Containerization for Aqueous Samples SOP-SA-01 Soil and Water Sample Packaging and Shipping SOP-DE-03 Investigation Derived Waste Handling



SOP-GW-14
FIELD WATER QUALITY
MEASUREMENTS
USING THE GEOTECH MULTI-PROBE
FLOWBLOCK FLOW THROUGH DEVICE

DATE ISSUED:
05/22/2015
REVISION: 0
PAGE 10 of 10

TOOLS	Geotech Flowblock, sample bottles, sample preservatives, water quality meters, spare batteries for the field measurement meters, ORP, electrode storage, specific conductivity, pH and ORP electrode cleaner, pH 4, pH 7, and pH 10 buffer solutions, de-ionized water, 5-gallon buckets, electronic depth to water level indicator, pump, stop watch, beaker, cooler, ice, purge containers and field logbook/field data sheets.
FORMS/CHECKLIST	

APPROVALS/CONCURRENCE	
By signing this document, all parties acknowledge the completeness and applicability of this SOP for its intended purpose. Also, by signing this document, it serves as acknowledgement that I have received training on the procedure and associated competency testing.	
SOP TECHNICAL AUTHOR	DATE
 Julie Flammang	05/22/2015
SAFETY AND HEALTH MANAGER	DATE
 Tara Schleeman	05/22/2015

Revisions:

Revision	Description	Date



**SOP-GW-15;
CONTINUOUS GROUNDWATER
LEVEL MONITORING
(SOLINST MODELS)**

DATE ISSUED: 06/05/2015
REVISION: 0
PAGE: 1 of 8

PURPOSE	To provide standard instructions for using a pressure transducer datalogger for continuous groundwater level measurements.
SCOPE	This practice has been prepared for the Pioneer Technical Services, Inc. (Pioneer) workforce and applies to work carried out by and on behalf of Pioneer. All members of the Pioneer workforce who conduct the work shall be trained and competent in the risk-assessed work described below.

WORK INSTRUCTIONS

The following instructions are intended to provide sufficient guidance to perform the task in a safe, accurate, and reliable manner. Should these instructions present information that is inaccurate or unsafe, operations personnel must bring the issue to the attention of the Project Manager and the appropriate revisions made. All work carried out under this Standard Operating Procedure (SOP) will be consistent with procedures and policies described in the appropriate Operation, Maintenance, and Monitoring (OM&M) Plan (where applicable), appropriate Site-Specific Health and Safety Plan (SSHASP), and Pioneer Corporate Health and Safety Plan (HASP).

TASK	INSTRUCTIONS
-------------	---------------------

Installation

1. Program transducer.	<p>It is recommended that transducers are programmed in the office rather than in the field to make sure everything is accurate (refer to manual for step-by-step instructions). The following information is needed when programming each transducer:</p> <ul style="list-style-type: none"> • Project ID. • Location. • Level – Units in feet. <ul style="list-style-type: none"> ○ Offset – Set to 0.0 feet. ○ Altitude – Set to 0.0 feet unless site topography varies over 1,000 feet in elevation (e.g., one transducer located in a valley while another transducer is located at the top of a hill). ○ Density – 1.0 kg/L. • Temperature – Units in degrees Celsius. • Standard Conductivity – Units in microsiemens per centimeter ($\mu\text{S}/\text{cm}$). • Datalogger Memory Mode – Set to slate mode. • Verification that the transducers and programming instrument (e.g., Solinst Leveloader™) are using the most current software/firmware. <p>There are different models of transducers that are currently being used. Each model may not record all of the parameters listed above.</p>
2. Determine the site-specific water column (static water level and total	Establish well specifics to determine water column (e.g., well log, if available) in an effort to bring enough supplies. Once in the field, verify water column information by using clean, non-contaminating equipment (e.g., an electronic depth to water level indicator [avoid indicating paste]), decontaminated per SOP-DE-02 Equipment Decontamination. Refer to SOP-GW-03 Depth to Water Level (DTW)



**SOP-GW-15;
CONTINUOUS GROUNDWATER
LEVEL MONITORING
(SOLINST MODELS)**

DATE ISSUED: 06/05/2015
REVISION: 0
PAGE: 2 of 8

depth) and its variability.	Measurements, measure and record DTW in the logbook. For consistent water level readings, use the same DTW meter during each site visit.
3. Determine hanging height of transducer.	Determination of the transducer hanging depth in the well is site specific and depends on the well and the water level fluctuation in the area. The main priority is to keep the transducer submerged at all times while making sure it is off of the bottom of the well where sediments can build up over time. Determine a depth at which to install the transducer.
4. Determine set up to secure the transducer to the PVC/well casing.	<p>There are many different ways to secure the transducer at the top of the well and to keep it in place depending on well construction and the project budget. Kevlar string or Dyneema[®] fiber work well to hang the transducer at the desired depth. Neither will stretch much after installation. It is imperative that the transducer is unable to shift/slide/slip/etc. from its original hanging position after it is attached to the polyvinyl chloride (PVC) or well casing. Again, this is site specific and should be verified with the Project Manager. If direct read cables are used, they must be properly secured to assure the transducer hanging height does not change and should have a backup hanging system (e.g., Kevlar string) in the event the cable is cut. Never attach the transducer to anything removable (e.g., well cap) unless there are no other means to attach the device.</p> <p>The easiest and most effective method for securing the transducer at a specified depth in the well is to install an eye-bolt or hook into the outer well casing (hook or eye should be to the inside of the casing). A large hose clamp over the inner PVC casing could also be used to secure the string. For security reasons, try to attach the string or direct read cable so that it is entirely contained within the outer well casing.</p> <p>Don a new pair of nitrile or latex gloves. Tie the string/fiber to the transducer. Measure the appropriate amount of string/fiber required to install the transducer at the determined depth plus a small amount to attach the string/fiber to the casing. While measuring the string/fiber, field personnel should wear latex or nitrile gloves and make sure the string/fiber does not contact the ground. Cut the string/fiber. If using a direct read cable, screw the direct read cable to the transducer. Care should be taken to only twist the connectors and not the cable. Measure out the appropriate amount of cable to install the transducer at the pre-determined depth, coil and secure any leftover cable with a zip tie. Secure the string/fiber to the hook, eye bolt or hose clamp at the top of the casing.</p>
5. Start the transducer.	If needed, remove the cap from the transducer and/or direct read cable. Using special care to only twist the connectors and not the cables, connect to the transducer or direct read cable using either the Leveloader [™] or a field laptop computer (pre-loaded with the most recent version of transducer specific software) using a PC connector cable. An optical reader can also be used in conjunction with the Leveloader [™] or a field laptop computer to program the transducer. Check, and if needed, set the present date and time. Daylight savings time should never be accounted for and the transducer's time should always be set to standard. The time should also be synced to an exact time (e.g., cell phone). Set the transducer for a future start time, never start at the current time. Double check the interval time set



**SOP-GW-15;
CONTINUOUS GROUNDWATER
LEVEL MONITORING
(SOLINST MODELS)**

**DATE ISSUED: 06/05/2015
REVISION: 0
PAGE: 3 of 8**

	<p>in the initial program setup (e.g., a reading every four hours, readings at 15-minute intervals, etc.). Set the future start time so that one of the interval loggings occurs at 12:00 AM. If transducers are to be installed in more than one well, set each transducer to start recording at the same future start time and the same logging interval.</p> <p>Once the programming is complete, close out of the program, and disconnect the transducer from the Leveloader™ or field laptop computer. Put the cap back on the transducer and/or the direct read cable, being careful to only twist the cap and not the cables.</p>
6. Deploy the transducer.	<p>Confirm that the string/fiber is firmly attached to both the transducer and the top of the well. Lower the transducer into the well slowly to the predetermined depth. Reconfirm that the string/fiber are firmly attached to the top of the well. Replace the well cap. Close and lock the well casing.</p>
7. Barologger installation.	<p>A Barologger will need to be installed to log barometric pressure. Barologger readings can be used to compensate any transducer data from wells that are within 1,000 feet of elevation and within a 20-mile radius. If possible, choose a central location that allows all transducers being installed to fall within these criteria. The Barologger can be installed within a well, above the high water level, at the location or in a nearby building. Additional Barologgers will need to be installed if any transducers fall outside of these parameters. Following the manufactures operating manual, set the Barologger to start at the same time as the transducers and record at the same time interval. The following information should also be programmed into the Barologger:</p> <ul style="list-style-type: none">• Project ID.• Location.• Level – Units in kPa.• Temperature – Units in degrees Celsius. <p>Installation of the Barologger is similar to installing a transducer. After verifying the high water level to avoid the Barologger coming into contact with water, cut a piece of Kevlar string or Dyneema® fiber to hang the Barologger at the desired height within the well casing. In an ideal situation the Barologger will be installed between the inner well casing (PVC) and the outer metal protective casing. The length of the string should allow the Barologger to hang down below the top of the inner well casing so it won't be disturbed during monitoring/sampling activities, but short enough that it doesn't touch the ground. The Barologger can also be installed within the inner well casing if there is not enough space between the inner and outer casing. The Barologger will need to be removed during sampling and monitoring activities. Do not remove it when a logging interval is near as it could impact the specific reading. The Barologger can be hung from the same eye-bolt, hook or hose clamp as the transducer, or hung using its own dedicated setup.</p>



**SOP-GW-15;
CONTINUOUS GROUNDWATER
LEVEL MONITORING
(SOLINST MODELS)**

DATE ISSUED: 06/05/2015
REVISION: 0
PAGE: 4 of 8

Downloading	
1. Measure the water level in the well.	The static water level must be measured prior to downloading the transducer. This insures the water column height was not compromised (e.g., pulling the transducer causing the water level to drop). Using clean, non-contaminating equipment (e.g., an electronic depth to water level indicator [avoid indicating paste]), decontaminated per SOP-DE-02 Equipment Decontamination, determine the water level in the well. Refer to SOP-GW-03 Depth to Water Level Measurements for instructions and record in the logbook. To ensure consistent water level readings an effort should be made to use the same DTW meter during each site visit. Rinse probe with DI water between locations.
2. Download data.	If a direct read cable was used in the well, connect to the transducer using either the Leveloader™ or a PC interface cable and the field laptop. If a direct read cable was not installed, don a pair of nitrile or latex gloves and remove the transducer from the well, noting the time on the field data sheet or in the field logbook. Place a piece of new plastic on the ground and place string on it as the transducer is removed from the well, alternately have field personnel collect the string so that it does not touch the ground during removal. Remove the cap from the transducer and/or direct read cable and place it in the optical reader or attach the PC interface cable (twist the connector, not the cable). Care should be taken not to misplace the cap removed from the transducer or direct read cable. The field laptop computer should have the most current software/firmware. Using either the Leveloader™ or the field laptop computer download the data (refer to manual for step-by-step instructions). If a direct read cable is installed, also record the real-time measurements in the logbook.
3. Start the transducer.	Set the transducer to a future start at a specific time (e.g. every four hours, 15-minute intervals, etc.) with one of the intervals logging at 12:00 AM. Never start at the current time.
4. Reinstall the transducer.	When downloading is complete, put the cap back on the direct read cable or transducer taking care not to twist the cable only the connectors. Replace the direct read cable inside the well casing or reinstall the transducer into the well as discussed in Step 6 above. Once the transducer is back in place note the time in the logbook or on the field data sheet. Close and lock the well casing.
Maintenance	
1. Battery Life	Each transducer has a 10-year battery life (based on one reading/min). Prior to transducer deployment, it is important to note the age of the instrument as well as monitor the battery level during each field visit. When reaching the end of the battery life, readings may begin to drift from the actual water levels. Periodic readings from the transducer should be compared to the manual water levels to help indicate the accuracy of the transducer and if it should be replaced.
2. Calibration	The Solinst® LTC Levelogger Junior F30/M10 transducer should be calibrated for conductivity every six months (refer to manual for step-by-step instructions).



**SOP-GW-15;
CONTINUOUS GROUNDWATER
LEVEL MONITORING
(SOLINST MODELS)**

DATE ISSUED: 06/05/2015
REVISION: 0
PAGE: 5 of 8

HSSE CONSIDERATIONS

This section to be completed with concurrence from the Safety and Health Manager.

<i>SOURCE</i>	<i>HAZARDS</i>	<i>WHERE</i>	<i>HOW, WHEN, RESULT</i>	<i>CONTROLS</i>
CHEMICAL	Potential contact with contaminated water.	Sites.	Inadvertent exposure to contaminated water could lead to adverse health effects.	Personnel will practice proper personal hygiene – wash hands prior to eating/drinking and when leaving the site. Employees will wear nitrile gloves and safety glasses during monitoring activities.
	Exposure to 1413 µs/cm calibration standard solution.	Equipment calibration.	The calibration standard solution may cause irritation of eyes and skin.	Personnel will practice proper personal hygiene – wash hands prior to eating and after calibrating equipment. Employees will wear nitrile gloves and safety glasses when handling the calibration standard solution.
NOISE	Not applicable.			
ELECTRICAL	Not applicable.			
BODY MECHANICS	Bending, squatting, and kneeling.	During monitoring activities.	Bending, squatting, and kneeling during monitoring activities could result in muscle/back strains or other injuries.	Employees should stretch prior to starting work and they will take breaks when necessary.
GRAVITY	Falls from slips and trips.	Uneven terrain, slick/muddy/wet surfaces and steep slopes.	Walking/working on slick/muddy/wet and uneven terrain could cause slips and trips resulting in falls and injuries.	Workers will wear work boots with good traction and ankle support. Personnel will be aware of working/walking surfaces and choose a path to avoid hazards. Keep work areas as dry as possible. Wear muck boots, as necessary.
WEATHER	Cold/heat stress.	Sites.	Exposure to cold climates may result in cold	Training on signs and symptoms of cold/heat stress is required. Personnel will wear



**SOP-GW-15;
CONTINUOUS GROUNDWATER
LEVEL MONITORING
(SOLINST MODELS)**

**DATE ISSUED: 06/05/2015
REVISION: 0
PAGE: 6 of 8**

	Lightning.	Outdoor sites.	burns, frostbites, and hypothermia. Exposure to high temperatures may result in heat cramps, heat exhaustion, or heat stroke. Electrocution, injury, death, or equipment damage could be caused by lightning strike.	appropriate clothing when working outdoors. Employees will remain hydrated and will have sufficient caloric intakes during the day. Personnel will follow procedures outlined in applicable SSHASP and/or Pioneer corporate HASP. Employees will follow the 30/30 rule during lightning storms.
RADIATION	Ultraviolet (UV) radiation.	Outdoors.	Employees could be exposed to UV radiation during summer months causing sun burns, skin damage, and eye damage.	Employees will wear safety glasses with tinted lenses, long-sleeve work shirts, and long pants. Employees should wear sunscreen, if necessary.
BIOLOGICAL	Plants, insects, and animals.	Sites.	Exposure to plants, insects, and/or animals may cause rashes, blisters, redness, and swelling.	Training on the signs and symptoms of exposure to plants, insects, and animals is required. Avoid contact with plants, insects, and animals. First-aid kits will be available on site. Employees with allergies will notify their supervisor.
MECHANICAL	Pinch points.	Well caps.	Personal injury could result from fingers getting pinched when opening/closing well caps.	Employees will wear work gloves when opening/closing well caps. Watch hand placement when opening/closing well caps.
PRESSURE	Not applicable.			
THERMAL	Not applicable.			



**SOP-GW-15;
CONTINUOUS GROUNDWATER
LEVEL MONITORING
(SOLINST MODELS)**

DATE ISSUED: 06/05/2015
REVISION: 0
PAGE: 7 of 8

HUMAN FACTORS	Inexperienced and improperly trained worker.	Sites.	Inexperienced workers and improper training could cause incidents resulting in adverse health effects and/or property damage.	Employees will be properly trained in this procedure and other applicable procedures. Employees will implement stop work procedures, if necessary.
	Interaction with public.	Sites.	Public can enter the work area and interfere with work activities.	Personnel will stop work, if public enters the work area. Work will resume once public has left the area.
SIMOPS	Not applicable.			

ADDITIONAL HSSE CONSIDERATIONS

This section to be completed with concurrence from the Safety and Health Manager.

REQUIRED PPE	Hard hat, safety glasses, high-visibility work shirt or vest, long pants, work boots, nitrile gloves, and work gloves.
APPLICABLE SDS	Safety Data Sheets (SDSs) will be maintained based on site characterization and contaminants. Standard conductivity calibration solution (1413 µS/cm).
REQUIRED PERMITS/FORMS	Per site/project requirements.
ADDITIONAL TRAINING	Per site/project requirements.

DRAWINGS, DOCUMENTS, AND TOOLS/EQUIPMENT

The following documents should be referenced to assist in completing the associated task.

P&IDS	
DRAWINGS	Map with site location and sample locations.
RELATED SOPs/PROCEDURES/WORK PLANS	SOP-DE-02 Equipment Decontamination and SOP-GW-03 Depth to Water Level Measurements.
TOOLS	Electronic depth to water level indicator, appropriate instrument connecting cables, eye bolt, string, piece of plastic sheeting, keys to locks, field laptop/Leveloader, field logbook, DI water, and standard conductivity calibration solution (1413 µS/cm).
FORMS/CHECKLIST	





**SOP-GW-15;
CONTINUOUS GROUNDWATER
LEVEL MONITORING
(SOLINST MODELS)**

**DATE ISSUED: 06/05/2015
REVISION: 0
PAGE: 8 of 8**

APPROVALS/CONCURRENCE

By signing this document, all parties acknowledge the completeness and applicability of this SOP for its intended purpose. Also, by signing this document, it serves as acknowledgement that I have received training on the procedure and associated competency testing.

SOP TECHNICAL AUTHOR	DATE
 Julie Flammang	06/05/2015
SAFETY AND HEALTH MANAGER	DATE
 Tara Schleeman	06/05/2015

Revisions:

Revision	Description	Date



**SOP-S-02;
SUBSURFACE SOIL
SAMPLING**

DATE ISSUED:
05/22/2015
REVISION: 0
PAGE 1 of 10

PURPOSE	To provide standard instructions for collecting subsurface soil samples.
SCOPE	This practice has been prepared for the Pioneer Technical Services, Inc. (Pioneer) workforce and applies to work carried out by and on behalf of Pioneer. All members of the Pioneer workforce who conduct the work shall be trained and competent in the risk-assessed work described below.
DEFINITIONS	<p><u>Subsurface Soil Sample</u>: it is defined as a mineral soil sample collected from 6 inches to 25 feet below ground surface. The need for biased sampling of subsurface soils should be evaluated by considering factors such as the precipitation, the type of soil and the length of time the site has been contaminated. If precipitation has moved contaminants into lower soil horizons, subsurface sampling may be appropriate.</p> <p>Several techniques can be used to collect samples from 6 inches to four or five feet below ground surface (bgs). A shovel and pry bar can be used to collect samples from 6 inches to 2 feet bgs. A hand auger may be used to collect subsurface samples up to four or five feet in depth. Because the auger is twisted into the soil the soil's cohesive structure and stratigraphic character are destroyed. An in situ soil recovery auger may also be used to collect subsurface samples up to five feet. The auger accommodates a liner and provides fast cutting of the soil with very little soil disturbance. In particularly rocky or hard soils a back hoe may be needed to excavate even shallow test pits. It is important to evaluate site conditions prior to choosing a subsurface sampling method. Each method of sampling will be discussed below.</p>

WORK INSTRUCTIONS

The following instructions are intended to provide sufficient guidance to perform the task in a safe, accurate, and reliable manner. Should these instructions present information that is inaccurate or unsafe, operations personnel must bring the issue to the attention of the Project Manager and the appropriate revisions made. All work carried under this SDS will be consistent with procedures and policies described in the appropriate Operation, Maintenance, and Monitoring (O&M) Plan (where applicable), appropriate Site-Specific Health and Safety Plan (SSHASP), and Pioneer Corporate Health and Safety Plan (HASP).

TASK	INSTRUCTIONS
Hang Dug Test Pits	
1. Coordinate utility locates.	Prior to site entry have a utility locate performed.
2. Locate sample site.	Locate the site as directed in the appropriate Sampling and Analysis Plan (SAP).
3. Conduct site walk.	Conduct a site walk through and determine any site-specific hazards associated with the sampling area. Discuss these with the sampling crew and note in the field logbook. During the site walk through note possible locations for underground utilities. For example, identify where natural gas pipes enter any structures on the property or if yard lights or street lights are present with no overhead lines. If sample locations have not been assigned in the SAP, note the probable locations of



**SOP-S-02;
SUBSURFACE SOIL
SAMPLING**

DATE ISSUED:
05/22/2015
REVISION: 0
PAGE 2 of 10

	underground utilities and try to avoid those areas when choosing sample locations. If sample locations are identified in the SAP use the appropriate survey method to locate.
4. Dig test pit.	Dig a 6 to 12-inch square pit to the depth specified in the SAP plus an additional 3 to 4 inches.
5. Identify sample intervals.	Measure the interval to be sampled with a stainless steel tape measure or a ruler and mark the appropriate interval.
6. Prepare sample location.	Scrape the walls of the sample pit within the marked interval with a decontaminated stainless steel trowel or scoop, a Teflon scoop, or a disposable plastic scoop to expose a clean surface.
7. Collect samples.	Place a stainless steel bowl or a clean decontaminated disposable foil pan adjacent to or in the sample pit and collect the sample by scraping the appropriate interval on the cleaned face of the pit with the sampling tool. If more than one interval is to be collected from the hole, collect the bottom or deepest interval first. If sampling for volatile organic compounds, the soil must be placed directly into the sample container with no head space and placed into a cooler with ice immediately.
8. Remove unnecessary material from sample.	Remove all coarse fragments greater than 0.5 inches from the bowl. Mix the remaining material in the bowl with the sampling tool.
9. Transfer sample to sample container.	Transfer the soil sample directly into the appropriate sample container according to SOP-SA-01 Soil and Water Sample Packaging and Shipping. Store samples in a cooler at 4°C or less.
10. Document sample information.	Record appropriate information about the sample and collection in the field logbook.
11. Decontaminate sampling tools.	Decontaminate sampling tools according to procedures outlined in SOP-DE-02 Equipment Decontamination.
Hand Auger Sampling	
1. Coordinate utility locates.	Prior to site entry have a utility locate performed.
2. Locate sample site.	Locate the site as directed in the appropriate Sampling and Analysis Plan (SAP).
3. Conduct site	Conduct a site walk through and determine any site-specific hazards associated with



**SOP-S-02;
SUBSURFACE SOIL
SAMPLING**

DATE ISSUED:
05/22/2015
REVISION: 0
PAGE 3 of 10

walk.	the sampling area. Discuss with the sampling crew and note in the field logbook. During the site walk through note possible locations for underground utilities. For example identify where natural gas pipes enter any structures on the property or if yard lights or street lights are present with no overhead lines. If sample locations have not been assigned in the SAP, note the probable locations of underground utilities and try to avoid those areas when choosing sample locations. If sample locations are identified in the SAP use the appropriate survey method to locate. Note the locations of overhead lines and overhead hazards and avoid those areas if possible.
4. Auger sample hole.	Place a large piece of plastic adjacent to the sample location. Choose the appropriate auger head for the soil type at the sample site (i.e., sand, mud, normal). Measure the length of the auger head to determine the advancement depth for each full auger. Place the auger at the sample location and begin turning, when the head is full remove the auger from the hole and empty the head onto the plastic. Measure the hole depth to determine the number of auger heads needed to reach the sample interval. Keep auguring and emptying the soil onto the plastic sheet until the top of the sampling interval is reached. The soil can be placed on the sheet in the order of removal for a general soil profile.
5. Collect sample.	Place a stainless steel bowl or a clean decontaminated disposable foil pan near the sample pit (preferably on a clean portion of the plastic) and collect the sample by emptying the auger head into the bowl or pan. Continue auguring and emptying the auger head into the sampling container throughout the entire sampling interval. If sampling for volatile organic compounds, the soil must be placed directly into the sample container with no head space and placed into a cooler with ice immediately.
6. Remove unnecessary material from sample.	Remove all coarse fragments greater than 0.5 inches from the bowl. Mix the remaining material in the bowl with the sampling tool.
7. Transfer sample to sample container.	Transfer the soil sample directly into the appropriate sample container according to SOP-SA-01 Soil and Water Sample Packaging and Shipping. Store samples in a cooler at 4°C or less.
8. Document sample information.	Record appropriate information about the sample and collection in the field logbook.
9. Decontaminate sample tools.	Decontaminate sampling tools according to procedures outlined in SOP-DE-02 Equipment Decontamination.



**SOP-S-02;
SUBSURFACE SOIL
SAMPLING**

DATE ISSUED:
05/22/2015
REVISION: 0
PAGE 4 of 10

<p>In-Situ Soil Recovery at Depths Greater than Five Feet A direct push soil recovery rig mounted on a truck or trailer is the most common method for the In-Situ Soil Recovery at Depths Greater than Five Feet and can be used to sample up to 75 feet or more in depth. There are also several types of hand augers with liner tubes that can be used for sampling up to 5 feet depending on soil type. The steps described in this section are for sampling from the liner tube.</p>	
1. Coordinate utility locates.	Prior to site entry have a utility locate performed.
2. Locate sample site.	Locate the site as directed in the appropriate Sampling and Analysis Plan (SAP).
3. Conduct site walk.	Walk through the site and determine any site-specific hazards associated with the sampling area. Discuss these with the sampling crew and note in the field logbook. During the site walk through note possible locations for underground utilities, for example identify where natural gas pipes enter any structures on the property or if yard lights or street lights are present with no overhead lines. If sample locations have not been assigned in the SAP, note the probable locations of underground utilities and try to avoid those areas when choosing sample locations. If sample locations are identified in the SAP, use the appropriate survey method to locate.
4. Probing or augering the sample hole.	Actual augering or drilling of the sampling holes will be conducted following the subcontractor's SOPs and safety protocols.
5. Collect sample.	As the plastic, Teflon or stainless steel liner is removed from the drill rod, make sure that the "top" of the liner, which represents the upper intervals is identified. If entire liner is being submitted for analysis seal both ends and mark the liner with the appropriate sample number and information. Place in a cooler and store at 4°C or less. If individual sample containers need to be collected or a composite sample over several intervals is to be collected place the liner on a work surface (portable table or plastic tarp on the ground). Cut the liner tube along its length. Label the top and bottom of the liner with the appropriate depths, index cards or pieces of paper placed at the top and bottom are acceptable. Photograph the core. Measure the amount of material present in the liner and if specified in the site-specific sampling plan log the core.
6. Prepare sample.	<p>Place a stainless steel bowl or a clean decontaminated disposable foil pan near the liner. Using a decontaminated stainless steel trowel or scoop, a Teflon scoop, or a disposable plastic scoop remove the appropriate interval from the liner and put it in the bowl/pan.</p> <p>If sampling for volatile organic compounds, place the soil directly into the appropriate sampling container, fill the container so that there is no head space, seal and place in a cooler with ice immediately.</p> <p>For all other analyses remove all coarse fragments greater than 0.5 inches from the bowl. Mix the remaining material in the bowl with the sampling tool.</p>



**SOP-S-02;
SUBSURFACE SOIL
SAMPLING**

**DATE ISSUED:
05/22/2015
REVISION: 0
PAGE 5 of 10**

7. Transfer sample to sample container.	Transfer the soil sample directly into the appropriate sample container according to SOP-SA-01 Soil and Water Sample Packaging and Shipping. Store samples in a cooler at 4°C or less.
8. Document sample information.	Record appropriate information about the sample and collection in the field logbook.
9. Decontaminate sample tools.	Decontaminate sampling tools according to procedures outlined in SOP-DE-02 Equipment Decontamination.



**SOP-S-02;
SUBSURFACE SOIL
SAMPLING**

DATE ISSUED:
05/22/2015
REVISION: 0
PAGE 6 of 10

HSSE CONSIDERATIONS

This section to be completed with concurrence from the Safety and Health Manager.

<i>SOURCE</i>	<i>HAZARDS</i>	<i>WHERE</i>	<i>HOW, WHEN, RESULT</i>	<i>CONTROLS</i>
CHEMICAL	Potential contact with contaminated soils.	Sample collection sites.	Inadvertent exposure to contaminated soils could lead to adverse health effects.	Personnel will practice proper personal hygiene – wash hands prior to eating and when leaving the site. Work will be suspended during high wind conditions that may produce large amounts of visible dust. Personnel will wear nitrile gloves and safety glasses when sampling and handling soil.
NOISE	Elevated noise levels.	Mechanized probing rig.	Personnel collecting soil samples can be exposed to elevated noise levels from the mechanized probing rig resulting in hearing damage.	Personnel collecting soil samples will set up the sampling station 25 feet away from the rig. The rig operator or helper will bring the plastic liner to the sampling station.
ELECTRICAL	Contact with underground utilities. Contact with overhead utilities.	Testing sites. Testing sites.	Serious injury could result from contact with a live buried utility. Walking near low hanging overhead utilities and generators on site could result in electrocution, shock, and burn due to contact or flashover.	Established ground disturbance procedures, as outlined in the Pioneer Corporate HASP will be followed. Visually inspect the sample location/yard prior to accessing. If overhead hazards are present, established overhead utility procedures will be followed. When possible, employees will avoid areas with overhead hazards.
BODY MECHANICS	Bending, squatting and kneeling.	During sample collection.	Bending, squatting and kneeling during sample collection and handling could result in	Personnel should stretch prior to starting work and they will take breaks when necessary. Personnel will use a foam pad or knee pads, if necessary.



**SOP-S-02;
SUBSURFACE SOIL
SAMPLING**

DATE ISSUED:
05/22/2015
REVISION: 0
PAGE 7 of 10

	Lifting and carrying tools, equipment, and/or samples.	Testing sites.	muscle/back strains or other injuries. Kneeling on gravel can result in bruises and knee injuries. Improper lifting and carrying tools, equipment, and/or samples could result in back injuries and muscle/back strains.	Personnel will use proper lifting techniques – get a good grip, keep the load close to the body, lift with legs and not with back, and avoid lifting loads above shoulder’s height. Two people will lift, if necessary.
GRAVITY	Falls from slips and trips.	Uneven terrain, slick surfaces and steep slopes.	Workers could get injured if they fall causing bruises, scrapes, or broken bones.	Workers will wear work boots with good traction and ankle support. Workers will plan their path and walk cautiously. Access areas will be established, if necessary.
WEATHER	Cold/heat stress. Lightning.	Sites. Testing sites.	Exposure to cold climates may result in cold burns, frostbites, and hypothermia. Exposure to high temperatures may result in heat cramps, heat exhaustion, or heat stroke. Electrocution, injury, death, or equipment damage could be caused by lightning strike.	Training on signs and symptoms of cold/heat stress. Personnel will wear appropriate clothing when working outdoors. Personnel will remain hydrated and will have sufficient caloric intakes during the day. Personnel will follow procedures outlined in applicable SSHASP and/or Pioneer corporate HASP. Employees will follow the 30/30 rule during lightning storms.
RADIATION	Ultraviolet (UV) radiation.	Outdoors.	Employees could be exposed to UV radiation during summer months causing sun	Employees will wear safety glasses with tinted lenses, long-sleeve work shirts, and long pants. Employees should wear sunscreen, if necessary.



**SOP-S-02;
SUBSURFACE SOIL
SAMPLING**

DATE ISSUED:
05/22/2015
REVISION: 0
PAGE 8 of 10

			burns, skin damage, and eye damage.	
BIOLOGICAL	Plants, insects, and animals.	Sites.	Exposure to plants, insects, and/or animals may cause rashes, blisters, redness, and swelling.	Training on the signs and symptoms of exposure to plants, insects, and animals is required. Avoid contact with plants, insects, and animals. First-aid kits will be available on site. Employees with allergies will notify their supervisor.
MECHANICAL	Pinch points.	Test pits.	Employees could cut their fingers if debris (e.g., glass, steel) is present in test pits. Personal injury to the hands could occur when using sampling equipment/tools.	Employees will wear nitrile gloves when sampling and handling soil. Employees will wear leather gloves while using sampling tools.
	Struck by shovel or auger.	Carrying tools.	Personnel can strike other workers or objects when carrying shovels and augers to/from sampling stations resulting in bodily injuries and/or property damage.	Personnel will be aware of their surroundings and, if needed, use a spotter. When carrying tools, maintain a safe distance (e.g., 4 feet or more depending on side of tool) from other workers.
	Hand injuries.	Liner cutter.	Employees could be exposed to hand injuries such as lacerations, punctures, and cuts when using the liner cutter and handling the cut liner.	Employees will wear work gloves when using the liner cutter. Be cautious of sharp edges when handling plastic core liners after they have been cut open. Workers will be trained on how to properly use the liner cutter. Two employees will cut liners,



**SOP-S-02;
SUBSURFACE SOIL
SAMPLING**

DATE ISSUED:
05/22/2015
REVISION: 0
PAGE 9 of 10

				if needed.
PRESSURE	Not applicable.			
THERMAL	Not applicable.			
HUMAN FACTORS	Inexperienced and improperly trained worker.	Sites.	Inexperienced workers and improper training could cause incidents resulting in adverse health effects and/or property damage.	Employees will be properly trained in this procedure and other applicable procedures. Employees will implement stop work procedures, if necessary.
	Public entering the work area.	Sites.	Third party members of the public could enter the work area resulting in an unsafe work environment.	Stop work if members of the public enter the work area.
SIMOPS	Not applicable.			

ADDITIONAL HSSE CONSIDERATIONS

This section to be completed with concurrence from the Safety and Health Manager.

REQUIRED PPE	Hard hat, safety glasses, high-visibility work shirt or vest, long pants, work boots, nitrile gloves, and leather gloves.
APPLICABLE SDS	Safety Data Sheets (SDSs) will be maintained based on site characterization and contaminants.
REQUIRED PERMITS/FORMS	Per site/project requirements.
ADDITIONAL TRAINING	Per site/project requirements.

DRAWINGS, DOCUMENTS, AND TOOLS/EQUIPMENT

The following documents should be referenced to assist in completing the associated task.

P&IDS	
DRAWINGS	Map with site location and sample locations.
RELATED SOPs/PROCEDURES/	SOP-SA-01 Soil and Water Sample Packaging and Shipping and SOP-DE-02 Equipment Decontamination.





**SOP-S-02;
SUBSURFACE SOIL
SAMPLING**

**DATE ISSUED:
05/22/2015
REVISION: 0
PAGE 10 of 10**

WORK PLANS	
TOOLS	Sampling tools (e.g., shovel, breaker bar, ruler, hand auger, plastic sheeting, trowel, sample containers, liner cutter, bowls, and camera) and field logbook. Decontamination equipment and fluids.
FORMS/CHECKLIST	

APPROVALS/CONCURRENCE

By signing this document, all parties acknowledge the completeness and applicability of this SOP for its intended purpose. Also, by signing this document, it serves as acknowledgement that I have received training on the procedure and associated competency testing.

SOP TECHNICAL AUTHOR	DATE
 Julie Flammang	05/22/2015
SAFETY AND HEALTH MANAGER	DATE
 Tara Schleeman	05/22/2015

Revisions:

Revision	Description	Date



SOP-S-12
SAMPLING SOIL FROM A
GEOPROBE® LINER

AUTHORIZED
VERSION:
 09/25/2020
 PAGE 1 of 14

PURPOSE	To provide standard instructions for sampling soil from a liner using a Geoprobe® unit.
SCOPE	Pioneer Technical Services, Inc. (Pioneer) prepared this practice for the workforce and this Standard Operating Procedure (SOP) applies to all work performed by and on behalf of Pioneer. All members of the Pioneer workforce who conduct the work shall be trained and competent (as defined by OSHA) in the risk-assessed procedure described below before performing the work.
WORK INSTRUCTIONS	
The following instructions provide guidance to perform the task in a safe, accurate, and reliable manner. If these instructions present information that is inaccurate or unsafe, personnel must notify the Project Manager, Safety Manager, and the SOP Technical Author to initiate appropriate revisions. Personnel will perform all work under this SOP in a manner that is consistent with procedures and policies described in the appropriate Operation, Maintenance, and Monitoring (O&M) Plan (where applicable), appropriate Site-Specific Health and Safety Plans (SSHASP), and Pioneer Corporate Health and Safety Plan (HASP).	
TASK	INSTRUCTIONS
Preparation	
1. Check of liner materials.	Make sure that the liner used to contain the soil in the Geoprobe® probe rods is made of material compatible with the contaminants being analyzed.
2. Set up the sample and staging area.	Cover a folding table with plastic. The table should be at least as long as the liners to be sampled. A tailgate covered with plastic can also be used. If the only available surface is the ground, place several layers of plastic a couple of feet longer than the liners. Secure the layers of plastic so they do not blow around during sampling. In addition to the sampling area, a staging area for unsampled core needs to be designated. This area should also be covered with plastic to keep the liners clean before placement on the sampling area.
3. Mark the liners.	As the Geoprobe® operator removes core (liners) from the probe rods, mark with a waterproof marker the “top” and “bottom” of the liner as well as the interval that the liner represents. Cap the liner ends with vinyl or Teflon end caps. Move core to the staging area.
4. Record information provided by the operator.	<p>If possible, confer with the Geoprobe® operator for any issues associated with probing each interval. Potential problems they may report:</p> <ul style="list-style-type: none"> • A loss of material due to a rock blocking the tube. • A section that drilled extremely easy indicating material that was easily compressed such as clay or debris. • The presence of a potential void. • A problem with recovery due to saturated soil. • Heaving sands, which could result in overestimation of the width or depth of a layer due to re-coring of the same interval.



SOP-S-12
SAMPLING SOIL FROM A
GEOPROBE® LINER

AUTHORIZED
VERSION:
 09/25/2020
 PAGE 2 of 14

	<ul style="list-style-type: none"> • Recognition of slough into the hole prior to drilling the next interval. <p>Record any information provided by the operator in the field logbook or on the field data sheet. This information can be referenced when logging the core.</p>
Sampling of Soil for Inorganic Constituents	
1. Cut the plastic liner lengthwise.	<p>The Geoprobe® operator and/or helper will cut the top portion of the plastic liner lengthwise. The opening along the top should be at least 2 inches wide. Care should be taken when handling and working around the cut liner as the cut edges are sharp.</p>
2. Place the liner on the prepared sampling surface.	<p>Place the liner on the prepared sampling surface and take the cut portion off. The portion of the liner marked “top” should be placed in the same direction on the sample surface each time. Place the index cards marked “top” and “bottom” on the appropriate ends of the liner. Place an extended tape measure adjacent to the liner. Index cards marked with appropriate intervals can also be used. Take a picture of the exposed soil. Do not move the tape measure or core after the photo.</p> <p>If the core does not need to be photographed, and it is NOT being analyzed for organics, mark the liner at the appropriate foot intervals with a Sharpie®.</p>
3. Measure and record material in the core.	<p>Measure and record the number of inches of material in the core, this will be recorded in the field logbook or on the field data sheet as “length recovered” (e.g., 36 inches from a 4-foot push or 18 inches from a 2-foot push). This measurement should not include any material that appears to have sloughed from an upper interval (i.e., leaves or topsoil present at the top of deeper subsurface cores). Record this information in the field logbook or on a field data sheet as specified in the Sampling and Analysis Plan (SAP).</p> <p>Evaluate the recovery of the core based on the operator’s comments. The preferred method is to determine the amount of material that represents 1 foot of the profile. For example, 36 inches of recovered soil from a 4-foot probe may indicate 9 inches were recovered per foot. An alternate method for determining interval depth is to assume that the 36 inches represents 36 inches from either the top or bottom of the probed interval and that there was no recovery for 4 inches of the interval. These are not precise ways to determine how far below ground surface a soil horizon lies, as different soil types and moisture levels will compress or expand differently when pushed with the probe. There is no way to determine where or whether compression / expansion in the soil profile occurred. Choose one of the methods and be consistent throughout the project.</p> <p>Another scenario that may occur is if the operator indicates an obstruction was encountered that may have blocked soil from entering the liner at the 2-foot interval in a probe. If there is only 24 inches of soil and a large rock present in the liner, this may represent only the 0-2 foot interval in that core and should be recorded that way in the field logbook or on the field data sheet along with the operator’s comment.</p>



SOP-S-12
SAMPLING SOIL FROM A
GEOPROBE® LINER

AUTHORIZED
VERSION:
09/25/2020
PAGE 3 of 14

4. Log the core.	<p>Examine and log the material in the liner. Check the project specific documents for the amount of detail or type of information required from the core log. Pioneer has developed several different field data sheets to aid in collecting the correct information during core logging.</p> <p>Keep in mind that due to smearing of soil during probing, a coating of wet or fine material may be present on the outside of the soil core. Using a gloved finger, make indentations down the core noting differences in texture, color, staining, or odor; to avoid cross contamination, change fingers as you make indentations. Record this information in the field logbook or on the field data sheet.</p>
5. Determine sample intervals.	<p>Determine sample intervals as described in the SAP or Work Plan (WP). If the material is NOT being sampled for organics, the sample intervals can be marked on the liner using a Sharpie®. An alternate method would be to separate the sample intervals so that a gap exists between the intervals. This makes it easier to get the appropriate intervals in the sample if the tape measure is moved during sampling activities.</p>
6. Collect soil samples.	<p>Slide the tube to the end of the table or sampling surface. Using a new plastic disposable scoop, slide the appropriate marked sample interval into a new disposable foil pan, stainless steel bowl, or resealable plastic bag. Alternately, instead of a scoop you can use a gloved finger or a clean screwdriver. A screwdriver is particularly helpful if portions of the soil are hardpacked or compressed. Mix the material in the pan/bowl thoroughly and remove rock and debris greater than 0.5 inches. If more material is required to fill sample containers, a second hole can be probed immediately adjacent to the first and material from the second liner from the same interval can be added to the pan/bowl and mixed.</p> <p>Repeat this process for all intervals to be sampled. Decontaminated bowls and screwdrivers and new foil pans, new resealable plastic bags, and new disposable scoops should be used for each interval sampled. Be aware of the potential for cross contamination and if needed change gloves between intervals.</p>
7. Put samples in containers.	<p>Prepare the appropriate sample containers with a label as described in the SAP or the Quality Assurance Project Plan. Fill the sample containers with homogenized material from the pan/bowl using the associated sampling tool.</p> <p>After sampling, place the samples in a cooler with ice until they can be transported to the laboratory for analysis as described in SOP-SA-01 Soil and Water Sample Packaging and Shipping.</p>
8. Record sampling information.	<p>Record appropriate information about the sample collection (sample number and associated depth interval, time, date, sample containers, etc.) in the field logbook as discussed in SOP-SA-05 Project Documentation. Record additional information such as soil type and rock content if required by the SAP/WP.</p>



SOP-S-12
SAMPLING SOIL FROM A
GEOPROBE® LINER

AUTHORIZED
VERSION:
 09/25/2020
 PAGE 4 of 14

9. Store or dispose of remaining core	Disposal or storage information should be available in the project-specific SAP/WP. In most cases, soil can be returned to the drill hole from which it came. If the information is not available in the SAP, discuss disposal requirements with the project manager.
Sampling of Soil for Organic Constituents	
1. Preparation prior to screening for volatile organic vapors in drill or Geoprobe® drill core.	<p>Photoionization detector (PID) meter readings are taken immediately upon opening the core, prior to any other sampling or logging activities. Soil samples can show significant losses in volatile organic compound (VOC) concentrations within only seconds of opening soil cores.</p> <p>If measurements using an organic vapor detector, PID, are required, please refer to SOP-FM-01 Field Headspace Analysis and VOC Measurements with PID for information on calibrating and using a PID for headspace analysis and VOC measurements.</p>
2. Place caps on the end of the core tubes.	Ensure that the Geoprobe® operator and/or helper place caps on the end of the core tubes immediately after removing the liner from the probe rod so that no VOCs escape prior to cutting open the core. Store capped core in the shade or on ice to avoid additional volatilization of VOCs. Do not have the operator/helper cut the tubes until just before core will be sampled.
3. Prepare the sample containers.	Based on information provided in the SAP/WP, prepare and label the appropriate sample containers. If samples are required, sample intervals may have been assigned in the SAP/WP, or samples may be collected based on PID or headspace readings or the presence of odor or staining. The sampler needs to understand sample collection protocol prior to opening the core liner. This is particularly important in collecting samples for VOC, volatile petroleum hydrocarbon (VPH), and/or extractable petroleum hydrocarbon [EPH] analysis. Ensure required sampling supplies are close at hand prior to opening core.
4. Cut the plastic liner lengthwise.	Have the Geoprobe® operator and/or helper cut the top portion of the plastic liner lengthwise. The opening should be at least 2 inches wide. DO NOT REMOVE THE CUT PORTION OF THE LINER. Care should be taken when handling and working around the cut liner as the cut edges are sharp.
5. Place the liner on the prepared sampling surface.	Place the liner on the prepared sampling surface. Do not remove the cut portion. Place the portion of the liner marked “top” in the same direction on the sample surface each time. Place the index cards marked “top” and “bottom” on the appropriate ends of the liner. Place an extended tape measure adjacent to the liner. Index cards marked with appropriate intervals can also be used.



SOP-S-12
SAMPLING SOIL FROM A
GEOPROBE® LINER

AUTHORIZED
VERSION:
 09/25/2020
 PAGE 5 of 14

6. Measure and record material in the core.	Prior to removing the cut portion of the liner, measure and record the number of inches of material in the core. See discussion in Step 3 of Sampling of Soil for Inorganic Constituents to determine how depth of sample intervals will be determined.
7. Take a picture of the exposed soil.	Remove the cut portion of the liner. Quickly take a picture of the exposed soil. Do not move the tape measure or core after the photo.
8. Conduct PID readings if required.	The VOC and VPH samples need to be collected as quickly as possible after opening the tube. If specified in the SAP/WP, use a PID to take readings of the length of the core, refer to SOP-FM-01 Field Headspace Analysis and VOC Measurements with PID for information on calibrating and using a PID for headspace analysis and VOC measurements.
9. Collect soil samples for VOC / VPH / EPH.	Collect the required VOC, VPH, or EPH samples directly from the tube using a plastic disposable scoop, gloved hand, or screwdriver. After VOC, VPH, and EPH samples are collected from all tubes/cores, collect inorganic (metals) samples if needed. The tape measure can be used to identify the intervals. Gaps from removed sample material should be left so that logging of the remaining core material can be completed. Place the soil directly into the sample container and fill the jar to the top allowing no head space (or as the laboratory directs). Be aware of the potential for cross contamination and if needed change gloves between intervals. New disposable scoops and a clean screwdriver should also be used for each sample interval. Immediately place the sample containers in a cooler with ice. Keep samples at 4 degrees Celsius (°C) or less and under chain of custody protocols until they can be transported to the laboratory for analysis as described in SOP-SA-01 Soil and Water Sample Packaging and Shipping.
10. Record PID readings and VOC sample information in Logbook.	If PID screening is conducted, record results of the screening in the field documentation (project logbook or field data sheets) and include the highest reading from each interval, the actual location in the core (i.e., 10 inches from the bottom), and the calculated interval depth. Record the sample information for the VOC, VPH, or EPH samples in the logbook and include time, date, and type of containers collected.
11. Continue sampling cores for VOCs.	Once the VOC samples have been collected from a section of core, replace the end caps and put the cut portion of the liner back on the core. The core can then be moved back to the staging area so that the next section of core can be screened and sampled for VOCs as quickly as possible. Process all available core for VOC samples prior to collecting inorganic samples or logging the core.
12. Log the core.	Once all the VOC samples have been collected. Logging the core can begin. Move a piece of core to the sample table and remove the cut portion of the liner, <i>being careful to keep it horizontal so as not to shift "gap" areas</i> . Realign the tape measure with the bottom and top of the tube. Examine and log the material in the liner. Check the project-specific documents for the amount of detail or type of information required regarding the core log. Pioneer has developed several different field data sheets to aid



SOP-S-12
SAMPLING SOIL FROM A
GEOPROBE® LINER

AUTHORIZED
VERSION:
 09/25/2020
 PAGE 6 of 14

	<p>in collecting the correct information during core logging.</p> <p>If the initial measurement of the length of core (Step 6 above) included slough, adjust the information on the field data sheet or logbook to reflect the actual length of core. Include information on material removed for VOC samples, as determined during sampling.</p> <p>Keep in mind that due to smearing of soil during probing, a coating of wet or fine material may be present on the outside of the soil core. Using a gloved finger, make indentations down the core and record the information in the field logbook or on the field data sheet; to avoid cross contamination, change fingers as you make indentations.</p>
<p>13. Prepare soil samples for additional analytes.</p>	<p>Sample intervals that are not going to be submitted for VOC, VPH, or EPH analysis can be sampled once logging of the core is completed. Ensure that all information from logging the core is recorded in the field logbook or on the field data sheet. Determine the intervals to be sampled for additional analytes. Separate the sample intervals for the inorganic samples, so that a gap is present between the intervals. This makes it easier to get the appropriate sections into the sample if the tape measure or core is moved. Record sample information and include interval sampled and associated sample number in the field logbook or on the field data sheet.</p>
<p>14. Collect soil samples.</p>	<p>Slide the tube to the end of the table or sampling surface. Using a new plastic disposable scoop, slide the appropriate marked sample interval into a new disposable foil pan or stainless steel bowl. Alternately, instead of a scoop you can use a gloved finger or a clean screwdriver. The screwdriver is particularly helpful if portions of the soil are hardpacked or compressed. Mix the material in the pan/bowl thoroughly and remove rock and debris greater than 0.5 inches. If more material is required to fill sample containers, a second hole can be probed immediately adjacent to the first and material from the second liner from the same interval can be added to the pan/bowl and mixed. Fill the sample containers with the homogenized materials from the pan/bowl using the associated sampling tool.</p> <p>Repeat this process for all intervals to be sampled. Be aware of the potential for cross contamination and if needed change gloves, screwdriver, or scoops between intervals.</p>
<p>15. Label the sample containers and store them in a cooler.</p>	<p>Make sure all sample containers are labeled correctly. These sample containers should also be placed in a cooler with ice (if required). Samples should be kept at 4 °C or less (if required by the analytical method) and under chain of custody protocols until transport to the laboratory as described in SOP-SA-01 Soil and Water Sample Packaging and Shipping.</p>



SOP-S-12
SAMPLING SOIL FROM A
GEOPROBE® LINER

AUTHORIZED
VERSION:
 09/25/2020
 PAGE 7 of 14

16. Record sampling information.	Record appropriate information about the sample collection (sample number and associated depth interval, time, date, sample containers, etc.) in the field logbook as discussed in SOP-SA-05 Project Documentation. Record additional information such as soil type and rock content if required by the SAP/WP.
17. Store or dispose of remaining core.	Disposal or storage information should be available in the project-specific SAP/WP. Soil with potential organic contamination will need to be contained for testing and potential landfarm treatment or disposal at an approved facility. If the information is not available in the SAP, discuss disposal requirements with the project manager. Removed soil may also be returned to the drill hole from which it came.
Decontamination of Equipment following both Organic or Inorganic Sampling	
1. Clean the plastic placed over the sample area.	Between each core, sweep or wipe down the plastic using paper towels wetted with deionized water (DI). If a particularly muddy core was sampled, the plastic may need to be replaced or a new piece placed over the sample area.
2. Decontaminate equipment.	Decontaminate the cutting tool, tape measure, and screwdrivers using paper towels wetted with a Liquinox/water mixture and the DI water spray bottle to rinse. If sampling for organics, use paper towels wetted with methanol for a final wipe down. If stainless steel bowls, spoons, and trowels were used, please follow instructions in SOP-DE-02 Equipment Decontamination.



**SOP-S-12
SAMPLING SOIL FROM A
GEOPROBE® LINER**

**AUTHORIZED
VERSION:
09/25/2020
PAGE 8 of 14**

HEALTH SAFETY SECURITY ENVIRONMENT (HSSE) CONSIDERATIONS

This section to be completed with concurrence from the Safety and Health Manager.

<i>SOURCE</i>	<i>HAZARDS</i>	<i>WHERE</i>	<i>HOW, WHEN, RESULT</i>	<i>CONTROLS</i>
CHEMICAL	Potential contact with contaminated soil and groundwater.	Sites.	Inadvertent exposure to contaminated soil and groundwater could lead to adverse health effects.	Personnel will practice proper personal hygiene – wash hands prior to eating/drinking and when leaving the site. Personnel will wear nitrile gloves and safety glasses when contact with soil and groundwater is possible. Sampling will be conducted outdoors or in a trailer with open doors.
	Exposure to hydraulic fluids.	Geoprobe® operations.	Exposure to hydraulic fluids could occur while working around the Geoprobe® due to equipment malfunction/failure resulting in personal injuries.	The operator will inspect the Geoprobe® and document inspections daily before starting work. The operator will also replace/repair all faulty equipment before starting work. When inspecting equipment, personnel will wear work gloves to prevent possible exposures to hydraulic fluids. Non-essential personnel will maintain a 20-foot buffer zone around the Geoprobe®.
	Liquinox.	Equipment decontamination.	Personnel could be exposed to Liquinox via ingestion and skin/eye contact when decontaminating the equipment resulting in adverse health effects.	Personnel will wear nitrile gloves and eye protection when decontaminating the equipment.



**SOP-S-12
SAMPLING SOIL FROM A
GEOPROBE® LINER**

**AUTHORIZED
VERSION:
09/25/2020
PAGE 9 of 14**

HEALTH SAFETY SECURITY ENVIRONMENT (HSSE) CONSIDERATIONS

This section to be completed with concurrence from the Safety and Health Manager.

<i>SOURCE</i>	<i>HAZARDS</i>	<i>WHERE</i>	<i>HOW, WHEN, RESULT</i>	<i>CONTROLS</i>
	Methanol.	Equipment decontamination.	Personnel could be exposed to methanol via skin/eye contact and ingestion/ inhalation when decontaminating equipment. Exposure could cause irritation of skin/eye. Adverse health effects can also result if methanol is ingested and/or inhaled. Direct contact with methanol during winter months can result in skin discomfort due to rapid evaporative cooling.	Personnel will prevent skin/eye contact with methanol and they will wear nitrile gloves and safety glasses when handling methanol. Personnel will use methanol in well-ventilated areas. Personnel will also practice proper personal hygiene – wash hands prior to eating/drinking, after decontamination procedures, and when leaving the site. During winter months, personnel will wear a pair of liner gloves underneath nitrile gloves.
NOISE	Elevated noise levels.	Geoprobe® operations.	Personnel could be exposed to elevated noise levels when working near the Geoprobe® operations resulting in hearing damage.	Personnel will wear hearing protection (e.g., ear plugs) when working near the Geoprobe®. Non-essential personnel will maintain a 20-foot buffer zone around the Geoprobe®, when possible. Hearing protection will be administered and used in accordance with the policies and procedures outlined in the Pioneer Corporate HASP.
ELECTRICAL	Not applicable.			



**SOP-S-12
SAMPLING SOIL FROM A
GEOPROBE® LINER**

**AUTHORIZED
VERSION:
09/25/2020
PAGE 10 of 14**

HEALTH SAFETY SECURITY ENVIRONMENT (HSSE) CONSIDERATIONS

This section to be completed with concurrence from the Safety and Health Manager.

<i>SOURCE</i>	<i>HAZARDS</i>	<i>WHERE</i>	<i>HOW, WHEN, RESULT</i>	<i>CONTROLS</i>
BODY MECHANICS	Bending, squatting, and kneeling.	During fieldwork activities.	Bending, squatting, and kneeling during fieldwork activities could result in muscle / back strains or other injuries.	Personnel should stretch prior to starting work and they will take breaks when necessary.
	Improper lifting / handling of heavy items.	During field work activities.	Back injuries and muscle/back strains could result when using improper techniques to lift/carry heavy coolers and containers with core pieces.	Personnel will use proper lifting techniques – get a good grip, keep the load close to the body, lift with legs and not with back, and avoid lifting loads above shoulder’s height. Two workers will lift/handle heavy items as needed.
	Flying debris.	Geoprobe® operations.	Eye injuries could result from flying debris when working around Geoprobe® operations.	Personnel will wear safety glasses when working around Geoprobe® operations. Non-essential personnel will maintain a 20-foot buffer zone around the Geoprobe® when possible.
GRAVITY	Falls from slips and trips.	Uneven terrain, slick/muddy/wet surfaces, and steep slopes.	Walking/working on slick/muddy/wet and uneven terrain could cause slips and trips resulting in falls and injuries.	Personnel will wear work boots with good traction and ankle support. They will plan their path, walk cautiously, and keep work areas as dry as possible. Personnel will wear muck boots as necessary.



**SOP-S-12
SAMPLING SOIL FROM A
GEOPROBE® LINER**

**AUTHORIZED
VERSION:
09/25/2020
PAGE 11 of 14**

HEALTH SAFETY SECURITY ENVIRONMENT (HSSE) CONSIDERATIONS

This section to be completed with concurrence from the Safety and Health Manager.

<i>SOURCE</i>	<i>HAZARDS</i>	<i>WHERE</i>	<i>HOW, WHEN, RESULT</i>	<i>CONTROLS</i>
WEATHER	Cold/heat stress.	Outdoor sites.	Exposure to cold climates may result in cold burns, frostbite, and hypothermia. Exposure to high temperatures may result in heat cramps, heat exhaustion, or heat stroke.	Training on signs and symptoms of cold/heat stress is required. Personnel will wear appropriate clothing when working outdoors (e.g., layers and loose clothing). Personnel will remain hydrated and will have sufficient caloric intakes during the day. Personnel will follow procedures outlined in the applicable SSHASP and/or Pioneer corporate HASP.
	Lightning.	Outdoor sites.	Electrocution, injury, death, or equipment damage could be caused by lightning strike.	Personnel will follow the 30/30 rule during lightning storms.
RADIATION	Ultraviolet (UV) radiation.	Outdoors sites.	Personnel could be exposed to UV radiation during summer months causing sun burns, skin damage, and eye damage.	Personnel will wear safety glasses with tinted lenses, long-sleeve work shirts, and long pants. Personnel should wear sunscreen, if necessary.
BIOLOGICAL	Plants, insects, and animals.	Outdoors.	Exposure to plants, insects, and/or animals may cause rashes, blisters, redness, and swelling.	Training on the signs and symptoms of exposure to plants, insects, and animals is required. Avoid contact with plants, insects, and animals. First aid kits will be available in company vehicles. Personnel with allergies will notify their supervisor.



SOP-S-12
SAMPLING SOIL FROM A
GEOPROBE® LINER

AUTHORIZED
VERSION:
 09/25/2020
 PAGE 12 of 14

HEALTH SAFETY SECURITY ENVIRONMENT (HSSE) CONSIDERATIONS

This section to be completed with concurrence from the Safety and Health Manager.

<i>SOURCE</i>	<i>HAZARDS</i>	<i>WHERE</i>	<i>HOW, WHEN, RESULT</i>	<i>CONTROLS</i>
MECHANICAL	Sharp edges and cutting tool.	Plastic liners and cutting tool.	Personal injury could result while cutting the plastic liners open to collect the soil samples. The plastic liners could also have sharp edges after they are cut. Cuts and scrapes could result from direct contact with sharp edges.	Personnel will use a specialized tool to cut the plastic liners and they will wear work gloves to prevent hand injuries. Personnel will use a tray and clamp to hold the plastic liner in place and keep it from moving around. Personnel will be aware of hand placement to prevent exposure to sharp edges and cutting tool.
PRESSURE	Pressurized hydraulic hoses.	Geoprobe®.	Hydraulic hoses could burst/rupture resulting in inadvertent contact with hydraulic fluid or personal injury due to being struck by hoses.	The operator will inspect the Geoprobe® and document inspections daily before starting work. The operator will also replace/repair all faulty equipment before starting work. When inspecting equipment, personnel will wear work gloves to prevent possible exposures to hydraulic fluids. Non-essential personnel will maintain a 20-foot buffer zone around the Geoprobe®.
THERMAL	Not applicable.			
HUMAN FACTORS	Inexperienced and improperly trained personnel.	Sites.	Inexperienced personnel and improper training could cause incidents resulting in adverse health effects and/or property damage.	Personnel will be properly trained in the procedure described above and other applicable procedures. Personnel will follow the stop work policy if there are any issues.



**SOP-S-12
SAMPLING SOIL FROM A
GEOPROBE® LINER**

**AUTHORIZED
VERSION:
09/25/2020
PAGE 13 of 14**

HEALTH SAFETY SECURITY ENVIRONMENT (HSSE) CONSIDERATIONS

This section to be completed with concurrence from the Safety and Health Manager.

<i>SOURCE</i>	<i>HAZARDS</i>	<i>WHERE</i>	<i>HOW, WHEN, RESULT</i>	<i>CONTROLS</i>
SIMOPS (Simultaneous Operations)	Not applicable.			

ADDITIONAL HSSE CONSIDERATIONS

This section to be completed with concurrence from the Safety and Health Manager.

REQUIRED PPE	Personal Protection Equipment (PPE): Hard hat, safety glasses, high-visibility work shirt or vest, long pants, work boots, nitrile gloves, and leather gloves.
APPLICABLE SDSs	Safety Data Sheets (SDSs) will be maintained based on the site characterization and contaminants. Safety Data Sheets are available to Pioneer personnel at the link below: https://pioneertechnicalservices.sharepoint.com/Safety/SafetyDataSheets
REQUIRED PERMITS/ FORMS	Per site/project requirements.
ADDITIONAL TRAINING	Per site/project requirements.

DRAWINGS, DOCUMENTS, AND TOOLS/EQUIPMENT

The following documents should be referenced to assist in completing the associated task.

DRAWINGS	Map with site location and sample locations.
RELATED SOPs/ PROCEDURES/ WORK PLANS	SOP-FM-01 Field Headspace Analysis and VOC Measurements with PID, SOP-SA-01 Soil and Water Sample Packaging and Shipping, SOP-DE-02 Equipment Decontamination (Inorganic Contaminants), and SOP-SA-05 Project Documentation.
TOOLS/ EQUIPMENT	Sample area – plastic sheeting, folding table (1 or 2), tape to secure plastic, tape measure, index cards to indicate top and bottom, camera, PID (if required), plastic disposable scoops or stainless steel spoons or spatulas, screwdrivers, filled DI water spray bottle, filled Liquinox/water spray bottle, methanol, paper towels, foil disposable pans or stainless steel bowls, sample containers, cooler, ice, dual blade cutter, and liner holders.
FORMS/ CHECKLIST	Field logbook and field data sheets.





**SOP-S-12
SAMPLING SOIL FROM A
GEOPROBE® LINER**

**AUTHORIZED
VERSION:
09/25/2020
PAGE 14 of 14**

APPROVALS/CONCURRENCE

By signing this document, all parties acknowledge the completeness and applicability of this SOP for its intended purpose. Also, by signing this document, it serves as acknowledgement that I have received training on the procedure and associated competency testing.

SOP TECHNICAL AUTHOR	DATE
 Julie Flammang	09/25/2020
SAFETY AND HEALTH MANAGER	DATE
 Tara Schleeman	09/25/2020



**SOP-S-13;
SAMPLING CORE FROM SONIC
DRILL**

**AUTHORIZED VERSION:
05/31/2018
PAGE 1 of 12**

PURPOSE	To provide standard instructions for sampling soil cores generated during sonic drilling.
SCOPE	This practice is for the Pioneer Technical Services, Inc. (Pioneer) workforce and applies to work carried out by and on behalf of Pioneer. All members of the Pioneer workforce who conduct the work shall be trained and competent in the risk-assessed work described below.
DISCUSSION	<p>Sonic drilling is accomplished by maintaining resonance of the drill string using an oscillator (the sonic drill head). As the resonance occurs, the soils immediately adjacent to the tooling are loosened and can move freely. Sonic drilling is particularly effective in areas where conventional drilling techniques might have problems, such as the presence of abundant cobbles or boulders, extremely dense till or cemented sands and gravels.</p> <p>The steps to soil sampling using a sonic drill rig are as follows:</p> <ol style="list-style-type: none"> 1. Sonically advance a core barrel into undisturbed soils. Runs are typically 10 feet, but longer or shorter runs are also possible. 2. Sonically override the core barrel with casing to the same depth. 3. Remove the core barrel to the surface and extrude the sample into a plastic sleeve in short sections for easy handling.

WORK INSTRUCTIONS

The following instructions are intended to provide sufficient guidance to perform the task in a safe, accurate, and reliable manner. Should these instructions present information that is inaccurate or unsafe, operations personnel must bring the issue to the attention of the Project Manager and the appropriate revisions made. All work performed under this Standard Operating Procedure (SOP) will be consistent with procedures and policies described in the appropriate Operation, Maintenance, and Monitoring (O&M) Plan (where applicable), appropriate Site-Specific Health and Safety Plan (SSHASP), and Pioneer Corporate Health and Safety Plan (HASP).

TASK	INSTRUCTIONS
Preparation	
1. Set up the sample area.	Designate an area near the drill rig that can be used for sampling and logging of core. The location should be out of the way of the drillers, but close enough to facilitate movement of the core to the area. Lay out sheets of plastic (visqueen) that are at least 15 feet long for 10 foot runs of core. Enough plastic should be laid out that all the core from the drill hole can be accommodated. The plastic sleeves containing the core need to be laid out with space to access them (walkways) for sampling and logging.
2. Determine the length of the cores.	Discuss with the drilling crew the length of core they will be providing in each plastic sleeve. In most cases, this will be about 10 feet. If Volatile Organic Compounds (VOC)/Volatile Petroleum Hydrocarbon (VPH) or other air sensitive analytes are being considered, a shorter length of core (e.g., 2 feet) might be appropriate for the best results.



**SOP-S-13;
SAMPLING CORE FROM SONIC
DRILL**

**AUTHORIZED VERSION:
05/31/2018
PAGE 2 of 12**

3. Mark the core.	As the drilling crew brings the plastic sleeve containing core to the sampling area, they should identify the top of the interval and place it on the liner in the appropriate location to keep the core in order from top to bottom.
4. Record information provided by the operator.	If possible, confer with the Sonic Drill operator for any issues associated with coring each interval. For example, was there a loss of material due to a rock blocking the tube, was there a section that drilled extremely easy and may indicate material that was easily compressed or perhaps the presence of a void, was there a problem with recovery due to saturated soils, etc. Record any information provided by the operator in the field logbook or on a field data sheet. This information can be referenced when logging the core.

Sampling of Soils for Inorganic Constituents

1. Slice the plastic along the top.	Using a utility knife or something similar slice the plastic along the top. Be aware that if the soil is saturated it may flow out of the plastic. In addition, water from saturated core may need to be “blocked” from flowing onto other sections of core. Place index cards or some other marker at intervals along the core. If possible, (plastic is not wet), intervals can be marked on the plastic. Place a reel tape measure along the core, so it can be easily referenced but out of the way.
2. Split the core and take pictures of the core.	If the core is cohesive, split the core lengthwise into two subsamples using a new disposable plastic spatula and/or stainless-steel blade. Photograph the complete length of the core in 2-foot segments from directly overhead using parallel camera movement and a high-resolution setting. These photographs can be stitched together later to provide a continuous photo record of the core. Take additional photographs of subsamples for documentation as necessary. If desired, take an overview picture of the exposed soils.
3. Measure and record material in the core.	<p>Measure and record the number of inches of material in the core. This will be recorded in the field logbook or on the field data sheet as length recovered. This measurement should not include any material that appears to have sluffed from an upper interval (i.e., leaves or topsoil present at the top of deeper subsurface cores). Record this information in the field logbook or on a field data sheet as specified in the Sampling and Analysis Plan (SAP).</p> <p>Evaluate the recovery of the core based on the operator’s comments. Be aware that once the core is cut open and released from the plastic, there may be some expansion. Recovery in general from sonic drill rigs is fairly complete. If there was trouble with the recovery, the operator should indicate in general where that might have occurred. Record any additional information in the field logbook or on a field data sheet.</p> <p>Determine the amount of material that represents one foot of the profile. For example, 26 inches of recovered soil from a 2-foot interval may indicate that 13 inches represents 1 foot. An alternate method for determining interval depth is to assume that 96 inches actually represents 96 inches from either the top or the bottom of a 120-inch interval and that there was no recovery for 12 inches of the interval. These are not precise ways to determine how far below ground surface a soil horizon lies, as different soil types</p>



**SOP-S-13;
SAMPLING CORE FROM SONIC
DRILL**

**AUTHORIZED VERSION:
05/31/2018
PAGE 3 of 12**

	<p>and moisture levels will compress or expand differently when drilled and then released with the opening of the sleeve. There is no way to determine where or whether compression/expansion in the soil profile occurred. Choose one of these methods and be consistent throughout the project.</p> <p>Another scenario that may occur would be if the operator indicates that an obstruction was encountered that may have blocked soils from entering the casing at a specific depth. If there is only 60 inches of soil and a large rock present in the sleeve, this may represent only the 0-5 foot interval in that core and should be recorded that way in the field logbook or on the field data sheet along with the operator's comment.</p>
<p>4. Log the core.</p>	<p>Examine and log the material in the core. Keep in mind that sonic-generated samples are not "undisturbed." The oscillation during drilling causes movement in the soils immediately adjacent to the core barrel. In softer bedrock, this may open fractures or round off edges of the material. Material closer to the center of the core should be used for logging and sampling. Using a gloved finger or scoop, make indentations down the core noting differences in texture, color, staining or odor if needed. The core may be unconsolidated enough that this is not required. Record information in the field logbook or on a field data sheet. Be aware of potential cross contamination when logging intervals that may be sampled. Change gloves or scoops as required. If required by the SAP or Work Plan (WP), photograph areas of interest.</p>
<p>5. Determine sample intervals.</p>	<p>Determine sample intervals as described in the SAP or WP. Using the extended tape measure, identify the intervals to be sampled. Record the sample interval information and associated sample number in the field logbook or on a field data sheet. If required in the SAP/WP, photograph sample intervals.</p>
<p>6. Sample soils.</p>	<p>For composite samples: Don clean nitrile gloves and use a new plastic disposable scoop for each composite sample. Place an equal aliquot of soil from each area to be composited into a new disposable foil pan or stainless-steel bowl. Mix the material in the pan/bowl thoroughly and remove rock and debris >0.5 inches. Fill the appropriate sample containers. Depending on the number of sample containers to be filled and the size of the core, a 0-1 foot sample interval may require compositing.</p> <p>For grab samples: Don clean nitrile gloves and use a new plastic disposable scoop for each sample. If more than one jar is required, place the material to be sampled in a new disposable foil pan or stainless-steel bowl. Mix the material in the pan/bowl thoroughly and remove rock and debris >0.5 inches. Fill the appropriate sample containers. Alternately, a new scoop can be used to place material directly in the jar. Sample carefully so no particles larger than 0.5 inches are included in the sample. Grab sampling may occur when there is a small stained area or a small amount of a material of interest in a soil profile.</p>



**SOP-S-13;
SAMPLING CORE FROM SONIC
DRILL**

**AUTHORIZED VERSION:
05/31/2018
PAGE 4 of 12**

7. Put samples in containers.	<p>Prepare the appropriate sample containers with a label as described in the SAP or the Quality Assurance Project Plan (QAPP). Fill the sample containers with homogenized material from the pan/bowl using the associated sampling tool.</p> <p>After sampling, place the samples in a cooler with ice until they can be transported to the laboratory for analysis as described in SOP-SA-01 Soil and Water Sample Packaging and Shipping.</p>
8. Repeat this process as needed.	Repeat this process for each sleeve until the drill hole is complete.
Sampling of Soils for Organic Constituents	
1. Prepare the core.	Evaluate the plastic sleeve of core to be sampled but DO NOT cut the plastic. If the soil is saturated, water or soils may flow out of the plastic after it is cut. Saturated core may need to be “blocked” from flowing onto other sections of core. Place index cards or some other marker at intervals along the core. If possible (e.g., plastic is not wet), intervals can be marked on the plastic. Place a reel tape measure along the core, so it can be easily referenced but out of the way.
2. Prepare the sample container.	Based on information provided in the SAP/WP, prepare the appropriate sample containers with a label as described in the SAP/QAPP.
3. Measure material in the core.	Prior to cutting the plastic sleeve, measure and record the number of inches of material in the core. See discussion in Step 3 of Sampling of Soils for Inorganic Constituents to determine how depth of sample intervals will be determined.
4. Cut the plastic sleeve.	Once the sample collection supplies are organized, use a utility knife or something similar and slice the plastic along the top.
5. Split the core.	Split the core lengthwise into two subsamples using a new disposable plastic spatula and/or stainless-steel blade.
6. Conduct PID readings if required.	Volatile Organic Compounds and VPH samples need to be collected as quickly as possible after opening the plastic. If specified in the SAP/WP, use a photoionization detector (PID) to take readings of the length of the core. Move slowly and if volatiles are detected, return to those areas and record the highest number measured as well as the amount of core involved. Evaluate the core for staining or other indications of organic contamination.
7. Prepare and collect soil samples for VOCs/VPH.	Determine sample intervals for VOCs/VPH as described in the SAP/WP. Sample intervals may be assigned in the SAP or based on PID readings or the presence of odor or staining. Photograph sample areas prior to sample collection. Collect the VOC/VPH samples directly from the core using a plastic disposable scoop or gloved hand. Place the soil directly into the sample container and fill the jar to the top allowing no head space (or as the laboratory directs). Be aware of the potential for cross contamination



**SOP-S-13;
SAMPLING CORE FROM SONIC
DRILL**

**AUTHORIZED VERSION:
05/31/2018
PAGE 5 of 12**

	<p>and change gloves or scoops between intervals. The tape measure can be used to identify the intervals sampled and are recorded in the field logbook or on a field data sheet.</p> <p>Immediately place the sample containers in a cooler with ice until they can be transported to the laboratory for analysis as described in SOP-SA-01 Soil and Water Sample Packaging and Shipping.</p>
<p>8. Prepare soil samples for additional analytes.</p>	<p>Sample intervals that are not going to be submitted for VOC/VPH can be collected after VOC/VPH sampling is completed. Prior to completing the sampling, finish logging the core and record all the information in the field logbook or on a field data sheet. Determine the intervals to be sampled for additional analytes. Record the sample interval information in the field log book or field data sheet.</p>
<p>9. Take pictures of the core.</p>	<p>Photograph the complete length of the core in 2-foot segments from directly overhead using parallel camera movement and a high-resolution setting. These photographs can be stitched together later to provide a continuous photo record of the core. Take additional photographs of subsamples for documentation as necessary. If desired, take an overview picture of the entire length of core.</p>
<p>10. Sample soils.</p>	<p>For composite samples: Don clean nitrile gloves and use a new plastic disposable scoop for each composite sample. Place an equal aliquot of soil from each area to be composited into a new disposable foil pan or stainless-steel bowl. Mix the material in the pan/bowl thoroughly and remove rock and debris >0.5 inches. Fill the appropriate sample containers. Depending on the number of sample containers to be filled and the size of the core, a 0-1 foot sample interval may require compositing.</p> <p>For grab samples: Don clean nitrile gloves and use a new plastic disposable scoop for each sample. If more than one jar is required, place the material to be sampled in a new disposable foil pan or stainless-steel bowl. Mix the material in the pan/bowl thoroughly and remove rock and debris >0.5 inches. Fill the appropriate sample containers. Alternately, a new scoop can be used to place material directly in the jar. Sample carefully so no particles larger than 0.5 inches are included in the sample. Grab sampling may occur when there is a small stained area or a small amount of a material of interest in a soil profile.</p> <p>Repeat this process for all intervals to be sampled. Be aware of the potential for cross contamination and if needed change gloves or scoops between intervals.</p>
<p>11. Label the sample containers and store them in a cooler.</p>	<p>Make sure all sample containers are labeled correctly. These sample containers should also be placed in a cooler with ice for transport to the laboratory as described in SOP-SA-01 Soil and Water Sample Packaging and Shipping.</p>



**SOP-S-13;
SAMPLING CORE FROM SONIC
DRILL**

**AUTHORIZED VERSION:
05/31/2018
PAGE 6 of 12**

Decontamination of Equipment following both Organic or Inorganic Sampling

- | | |
|-----------------------------|---|
| 1. Decontaminate equipment. | Decontaminate the cutting tool and tape measure, as well as any other reusable equipment using paper towels wetted with a Liquinox/water mixture and the deionized (DI) water spray bottle to rinse. If sampling for organics, use paper towels wetted with methanol for a final wipe down. If stainless steel bowls, spoons and trowels were used, please follow the SOP-DE-02 Decontamination of Equipment. |
|-----------------------------|---|



**SOP-S-13;
SAMPLING CORE FROM SONIC
DRILL**

AUTHORIZED VERSION:
05/31/2018
PAGE 7 of 12

HSSE CONSIDERATIONS

This section to be completed with concurrence from the Safety and Health Manager.

<i>SOURCE</i>	<i>HAZARDS</i>	<i>WHERE</i>	<i>HOW, WHEN, RESULT</i>	<i>CONTROLS</i>
CHEMICAL	Potential contact with contaminated soils and groundwater.	Sites.	Inadvertent exposure to contaminated soils and groundwater could lead to adverse health effects.	Personnel will practice proper personal hygiene – wash hands prior to eating/drinking and when leaving the site. Personnel will wear nitrile gloves and safety glasses when contact with soils and groundwater is possible. Sampling will be conducted outdoors or in a trailer with open doors.
	Exposure to hydraulic fluids.	Drilling operations.	Exposure to hydraulic fluids could occur while working around the drill due to equipment malfunction/failure resulting in personal injuries.	The operator will inspect the drill and document inspections daily before starting work. The operator will also replace/repair all faulty equipment before starting work. When inspecting equipment, personnel will wear work gloves to prevent possible exposures to hydraulic fluids. Non-essential personnel will maintain a 20-foot buffer zone round the drill.
	Liquinox.	Equipment decontamination.	Personnel could be exposed to Liquinox via ingestion and skin/eye contact when decontaminating the equipment resulting in adverse health effects.	Personnel will wear nitrile gloves and eye protection when decontaminating the equipment.



**SOP-S-13;
SAMPLING CORE FROM SONIC
DRILL**

**AUTHORIZED VERSION:
05/31/2018
PAGE 8 of 12**

CHEMICAL	Methanol.	Equipment decontamination.	<p>Personnel could be exposed to methanol via skin/eye contact and ingestion/ inhalation when decontaminating equipment. Exposure could cause irritation of skin/eye. Adverse health effects can also result, if methanol is ingested and/or inhaled. Direct contact with methanol during winter months can result in skin discomfort due to rapid evaporative cooling.</p>	<p>Personnel will prevent skin/eye contact with methanol and they will wear nitrile gloves and safety glasses when handling methanol. Personnel will use methanol in well-ventilated areas. Personnel will also practice proper personal hygiene – wash hands prior to eating/drinking, after decontamination procedures, and when leaving the site. During winter months, personnel will wear a pair of liner gloves underneath nitrile gloves.</p>
NOISE	Elevated noise levels.	Drilling operations.	<p>Personnel could be exposed to elevated noise levels when working near the drilling operations resulting in hearing damage.</p>	<p>Personnel will wear hearing protection (e.g., ear plugs) when working near the drill. Non-essential personnel will maintain a 20-foot buffer zone around the drill when possible. Hearing protection will be administered and used in accordance with the policies and procedures outlined in the Pioneer Corporate HASP.</p>
ELECTRICAL	Not applicable.			



SOP-S-13;
SAMPLING CORE FROM SONIC
DRILL

AUTHORIZED VERSION:
05/31/2018
PAGE 9 of 12

BODY MECHANICS	Bending, squatting, and kneeling.	During fieldwork activities.	Bending, squatting, and kneeling during fieldwork activities could result in muscle/back strains or other injuries.	Personnel should stretch prior to starting work and they will take breaks when necessary.
	Improper lifting/handling of heavy items.	During field work activities.	Back injuries and muscle/back strains could result when using improper techniques to lift/carry heavy coolers and containers with core pieces.	Personnel will use proper lifting techniques – get a good grip, keep the load close to the body, lift with legs and not with back, and avoid lifting loads above shoulder’s height. Two workers will lift/handle heavy items as needed.
	Flying debris.	Drilling operations.	Eye injuries could result from flying debris when working around drilling operations.	Personnel will wear safety glasses when working around drilling operations. Non-essential personnel will maintain a 20-foot buffer zone around the drill when possible.
GRAVITY	Falls from slips and trips.	Uneven terrain, slick/muddy/wet surfaces, and steep slopes.	Walking/working on slick/muddy/wet and uneven terrain could cause slips and trips resulting in falls and injuries.	Personnel will wear work boots with good traction and ankle support. They will plan their path, walk cautiously, and keep work areas as dry as possible. Personnel will wear muck boots as necessary.
WEATHER	Cold/heat stress.	Outdoor sites.	Exposure to cold climates may result in cold burns, frostbite, and hypothermia. Exposure to high temperatures may result in heat cramps, heat	Training on signs and symptoms of cold/heat stress is required. Personnel will wear appropriate clothing when working outdoors (e.g., layers and loose clothing). Personnel will remain hydrated and will have sufficient caloric intakes during the day. Personnel will follow procedures outlined in



**SOP-S-13;
SAMPLING CORE FROM SONIC
DRILL**

**AUTHORIZED VERSION:
05/31/2018
PAGE 10 of 12**

WEATHER	Lightning.	Outdoor sites.	exhaustion, or heat stroke. Electrocution, injury, death, or equipment damage could be caused by lightning strike.	the applicable SSHASP and/or Pioneer corporate HASP. Personnel will follow the 30/30 rule during lightning storms.
RADIATION	Ultraviolet (UV) radiation.	Outdoors sites.	Personnel could be exposed to UV radiation during summer months causing sun burns, skin damage, and eye damage.	Personnel will wear safety glasses with tinted lenses, long-sleeve work shirts, and long pants. Personnel should wear sunscreen, if necessary.
BIOLOGICAL	Plants, insects, and animals.	Outdoors.	Exposure to plants, insects, and/or animals may cause rashes, blisters, redness, and swelling.	Training on the signs and symptoms of exposure to plants, insects, and animals is required. Avoid contact with plants, insects, and animals. First aid kits will be available in company vehicles. Personnel with allergies will notify their supervisor.
MECHANICAL	Blade from cutting tool.	Cutting tool.	Direct contact with the blade of the cutting tool used for slicing the plastic sleeves could result in cuts and scrapes.	Personnel will inspect the cutting tool prior to each use and be aware of hand placement to prevent exposure to the blade. Personnel will also wear work gloves.
PRESSURE	Pressurized hydraulic hoses.	Drilling operations.	Hydraulic hoses could burst/rupture resulting in inadvertent contact with hydraulic fluid or personal injury	The operator will inspect the drill and document inspections daily before starting work. The operator will also replace/repair all faulty equipment before starting work. When inspecting equipment, personnel will wear work gloves to prevent possible exposures to hydraulic fluids.



**SOP-S-13;
SAMPLING CORE FROM SONIC
DRILL**

**AUTHORIZED VERSION:
05/31/2018
PAGE 11 of 12**

			due to being struck by hoses.	Non-essential personnel will maintain a 20-foot buffer zone round the drill.
THERMAL	Not applicable.			
HUMAN FACTORS	Inexperienced and improperly trained personnel.	Sites.	Inexperienced personnel and improper training could cause incidents resulting in adverse health effects and/or property damage.	Personnel will be properly trained in the procedure described above and other applicable procedures. Personnel will follow the stop work policy, if there are any issues.
SIMOPS	Not applicable.			
ADDITIONAL HSSE CONSIDERATIONS				
This section to be completed with concurrence from the Safety and Health Manager.				
REQUIRED PPE	Personal Protective Equipment (PPE): Hard hat, safety glasses, high-visibility work shirt or vest, long pants, work boots, nitrile gloves, and leather gloves.			
APPLICABLE SDSs	Liquinox and Methanol. Additional Safety Data Sheets (SDSs) will be maintained based on the site characterization and contaminants.			
REQUIRED PERMITS/ FORMS	Per site/project requirements.			
ADDITIONAL TRAINING	Per site/project requirements.			



**SOP-S-13;
SAMPLING CORE FROM SONIC
DRILL**

**AUTHORIZED VERSION:
05/31/2018
PAGE 12 of 12**



DRAWINGS, DOCUMENTS, AND TOOLS/EQUIPMENT

The following documents should be referenced to assist in completing the associated task.

DRAWINGS	Map with site location and sample locations.
RELATED SOPs/ PROCEDURES /WORK PLANS	SOP-SA-01 Soil and Water Sample Packaging and Shipping and SOP-DE-02 Equipment Decontamination – Inorganic Contaminants.
TOOLS	Sample area – plastic sheeting, tape measure, index cards to indicate top and bottom, camera, PID (if required), plastic disposable scoops or stainless-steel spoons or spatulas, screwdrivers, DI water spray bottle, Liquinox/water spray bottle, methanol, paper towels, foil disposable pans or stainless-steel bowls, sample containers, cutting tool (e.g., utility knife).
FORMS/ CHECKLIST	Field logbook and field data sheets.

APPROVALS/CONCURRENCE

By signing this document, all parties acknowledge the completeness and applicability of this SOP for its intended purpose. Also, by signing this document, it serves as acknowledgement that I have received training on the procedure and associated competency testing.

SOP TECHNICAL AUTHOR	DATE
 Julie Flammang	05/31/2018
SAFETY AND HEALTH MANAGER	DATE
 Tara Schleeman	05/31/2018



**SOP-SA-01;
SOIL AND WATER SAMPLE
PACKAGING AND SHIPPING**

DATE ISSUED:
12/11/2014
REVISION: 0
PAGE 1 of 5

PURPOSE	To provide standard instructions for soil and water sample packaging and shipping.
SCOPE	This practice has been prepared for the Pioneer Technical Services, Inc. (Pioneer) workforce and applies to work carried out by and on behalf of Pioneer. All members of the Pioneer workforce who conduct the work shall be trained and competent in the risk-assessed work described below.

WORK INSTRUCTIONS

The following instructions are intended to provide sufficient guidance to perform the task in a safe, accurate, and reliable manner. Should these instructions present information that is inaccurate or unsafe, operations personnel must bring the issue to the attention of the Project Manager and the appropriate revisions made. All work carried under this SOP will be consistent with procedures and policies described in the appropriate Operation, Maintenance, and Monitoring (O&M) Plan (where applicable), appropriate Site-Specific Health and Safety Plan (SSHASP), and Pioneer Corporate Health and Safety Plan (HASP).

TASK	INSTRUCTIONS
1. Preserve the samples.	Water samples will be preserved, if required, according to SOP-SA-02 Sample Preservation and Containerization for Aqueous Samples, and SOP-SA-02B Sample Preservation and Containerization for Aqueous Samples for VOAs.
2. Place the sample containers in Ziploc bags.	Based on the analytes requested (e.g., low level mercury, low level chromium, etc.), it may be necessary to place each filled sample container in separate Ziploc bags to prevent cross contamination, keep the container clean, dry, and isolated, and protect the sample label. In most cases, all sample containers collected from a specific sample location are placed in a large Ziploc bag and shipped together.
3. Package the samples.	Place samples in a cooler, which has been previously lined with a plastic bag. Surround the samples with non-contaminating packaging materials to reduce movement and absorb any leakage. Double bag the ice and place it in the cooler. Seal the plastic bag in the cooler to contain the samples, packing material, and ice.
4. Review and sign COC forms.	The Field Team Leader or their designated representative will double check the chain-of-custody (COC) forms to assure those samples recorded on the COC forms are in the cooler. The Field Team Leader or the designated representative will then sign the chain-of-custody form to relinquish custody. One copy of the signed COC form will remain with the Field Team Leader. Make a photocopy of the completed forms, if there are no carbon copies available.
5. Tape paper work to cooler.	Place paper work in a sealed Ziploc bag and tape it to the inside of the cooler lid.
6. Bag samples for separate analytical batches.	If the shipping cooler contains more samples than can be analyzed in one analytical batch, the laboratory may request that the samples in the cooler be bagged for separate analytical batches. This may be necessary so that the appropriate Quality Control/Quality Assurance samples are included in each analytical batch. In this case, fill out separate COC forms for each batch and include the forms in the



**SOP-SA-01;
SOIL AND WATER SAMPLE
PACKAGING AND SHIPPING**

DATE ISSUED:
12/11/2014
REVISION: 0
PAGE 2 of 5

	<p>appropriate plastic bags. Place the COC forms for each batch in a sealed Ziploc bag. The COC forms for each batch should be placed at the top of the plastic bag so that they are clearly visible to laboratory personnel when they open the plastic bags.</p>
<p>7. Label the cooler.</p>	<p>Label the cooler with the appropriate labels to describe the content of the cooler (e.g., NOS, flammable liquids, flammable solids, this side up, fragile, etc.).</p> <p>Close the cooler and place the appropriate shipping labels (e.g., overnight shipping from Federal Express, UPS, or the United States Postal Service or equivalent) on the lid of the cooler.</p>
<p>8. Sign COC seals.</p>	<p>The Field Team Leader or the designated representative will sign COC seals and place the signed seals over the opening edge of the cooler.</p>
<p>9. Tape the cooler.</p>	<p>Place tape over the custody seals and around the cooler.</p>
<p>10. Transport the cooler.</p>	<p>Transport the cooler(s) to a secure storage, to the shipping agent, or directly to the laboratory.</p> <p>If shipping the cooler, follow established federal and state regulations depending on cooler content.</p>
<p>Notes</p>	<p>Bagging of samples and lining of coolers is not necessary, if samplers transport the samples directly to the laboratory.</p>



**SOP-SA-01;
SOIL AND WATER SAMPLE
PACKAGING AND SHIPPING**

DATE ISSUED:
12/11/2014
REVISION: 0
PAGE 3 of 5

HSSE CONSIDERATIONS

This section to be completed with concurrence from the Safety and Health Manager.

<i>SOURCE</i>	<i>HAZARDS</i>	<i>WHERE</i>	<i>HOW, WHEN, RESULT</i>	<i>CONTROLS</i>
CHEMICAL	<p>Potential contact with contaminated soil and water samples.</p> <p>Preservatives (HCL, HNO₃, H₂SO₄, Zinc, Acetate, NaOH).</p>	<p>Sites.</p> <p>In bottles or added to bottles through sampling process.</p>	<p>Inadvertent exposure to contaminated soil and water samples could lead to adverse health effects.</p> <p>Inadvertent exposure to preservatives could lead to adverse health effects.</p>	<p>Personnel will practice proper personal hygiene – wash hands prior to eating/drinking and when leaving the site. Employees will wear nitrile gloves and safety glasses when handling sample containers.</p> <p>Safety Data Sheets for each preservative chemical are available to all employees on the Pioneer company web site. Personnel will wear nitrile gloves and safety glasses when adding preservatives to samples bottles and when handling the bottles. Refer to the Chemical Flushing Guidelines available inside vehicle's first aid kit for first-aid procedures in case of contact with preservatives.</p>
NOISE	Not applicable.			
ELECTRICAL	Not applicable.			
BODY MECHANICS	<p>Bending, squatting, and kneeling.</p> <p>Improper lifting.</p>	<p>During sample packaging.</p> <p>Sites.</p>	<p>Bending, squatting, and could result in muscle/back strains or other injuries.</p> <p>Back injuries and muscle/back strains could result when using improper techniques to lift and carry coolers with samples.</p>	<p>Employees should stretch prior to starting work and they will take breaks when necessary.</p> <p>Personnel will use proper lifting techniques – get a good grip, keep the load close to the body, lift with legs and not with back, and avoid lifting loads above shoulder's height. Two workers will lift/carry the coolers, if needed.</p>



SOP-SA-01;
SOIL AND WATER SAMPLE
PACKAGING AND SHIPPING

DATE ISSUED:
 12/11/2014
REVISION: 0
 PAGE 4 of 5

GRAVITY	Not applicable.			
WEATHER	Not applicable.			
RADIATION	Not applicable.			
BIOLOGICAL	Not applicable.			
MECHANICAL	Not applicable.			
PRESSURE	Not applicable.			
THERMAL	Not applicable.			
HUMAN FACTORS	Inexperienced and improperly trained worker.	Sites.	Inexperienced workers and improper training could cause incidents resulting in adverse health effects and/or property damage.	Employees will be properly trained in this procedure and other applicable procedures. Employees will implement stop work procedures, if necessary.
SIMOPS	Not applicable.			

ADDITIONAL HSSE CONSIDERATIONS

This section to be completed with concurrence from the Safety and Health Manager.

REQUIRED PPE	Sampling site: hard hat, safety glasses, high-visibility work shirt or vest, long pants, work boots, and nitrile gloves. Off site: nitrile gloves.
APPLICABLE SDS	HCL, HNO3, H2SO4, Zinc, Acetate, and NaOH. Additional Safety Data Sheets (SDSs) will be maintained based on site characterization and contaminants.
REQUIRED PERMITS/FORMS	Per site/project requirements.
ADDITIONAL TRAINING	Per site/project requirements.



SOP-SA-01;
SOIL AND WATER SAMPLE
PACKAGING AND SHIPPING

DATE ISSUED:
 12/11/2014
REVISION: 0
 PAGE 5 of 5



DRAWINGS, DOCUMENTS, AND TOOLS/EQUIPMENT

The following documents should be referenced to assist in completing the associated task.

P&IDS	
DRAWINGS	
RELATED SOPs/PROCEDURES/WORK PLANS	SOP-SA-02 Sample Preservation and Containerization for Aqueous Samples and SOP-SA-02B Sample Preservation and Containerization for Aqueous Samples for VOAs.
TOOLS	Plastic bags, Ziploc bags, non-contaminating packaging materials, tape, COC seals, ice, and cooler.
FORMS/CHECKLIST	Chain-of-custody (COC) forms.

APPROVALS/CONCURRENCE

By signing this document, all parties acknowledge the completeness and applicability of this SOP for its intended purpose. Also, by signing this document, it serves as acknowledgement that I have received training on the procedure and associated competency testing.

SOP TECHNICAL AUTHOR	DATE
 Julie Flammang	12/11/2014
SAFETY AND HEALTH MANAGER	DATE
 Tara Schleeman	12/11/2014

Revisions:

Revision	Description	Date



**SOP-SA-02;
SAMPLE PRESERVATION AND
CONTAINERIZATION FOR
AQUEOUS SAMPLES**

DATE ISSUED:
05/28/2015
REVISION: 0
PAGE 1 of 8

PURPOSE	The SOP covers aqueous samples being analyzed for commonly requested organic, inorganic and RADCHEM parameters. Guidance is provided on industry standard containers, preservatives, analytical methods and holding times associated with sample collection.
SCOPE	This practice has been prepared for the Pioneer Technical Services, Inc. (Pioneer) workforce and applies to work carried out by and on behalf of Pioneer. All members of the Pioneer workforce who conduct the work shall be trained and competent in the risk-assessed work described below.
WORK INSTRUCTIONS	
The following instructions are intended to provide sufficient guidance to perform the task in a safe, accurate, and reliable manner. Should these instructions present information that is inaccurate or unsafe, operations personnel must bring the issue to the attention of the Project Manager and the appropriate revisions made. All work carried under this SOP will be consistent with procedures and policies described in the appropriate Operation, Maintenance, and Monitoring (O&M) Plan (where applicable), appropriate Site-Specific Health and Safety Plan (SSHASP), and Pioneer Corporate Health and Safety Plan (HASP).	
TASK	INSTRUCTIONS
Notes	<p>Most bottles come certified and preserved from the laboratory. If bottles do not contain preservatives, field personnel will add it at the time of water sample collection.</p> <p>If bottles are not certified, a triple rinse with the water to be sampled will be done before collecting the sample. Preservative will be added to the sample container after triple rinse and before sample collection.</p> <p>The following information was supplied to Pioneer from Pace Analytical Services. If another laboratory is contracted for analyzing samples, verify with the laboratory the appropriate containers, preservatives and holding time limits for the required analyses.</p> <p>If a different analytical method is specified in the Sampling and Analysis Plan (SAP) from those listed below verify with the contracted laboratory for sampling method, container requirements, preservative and holding time limits.</p>
Label samples	Label samples as per SOP-SA-01 Soil and Water Sample Packaging and Shipping.



**SOP-SA-02;
SAMPLE PRESERVATION AND
CONTAINERIZATION FOR
AQUEOUS SAMPLES**

**DATE ISSUED:
05/28/2015
REVISION: 0
PAGE 2 of 8**

Organic Parameters in Aqueous Samples

Parameter	Method			Container	Preservative	Max Hold Time
	EPA Drinking Water	EPA Water	EPA Waste SW-846			
Aromatic and Halogenated Volatiles		601/602	8021	3 - 40mL vials	pH<2 HCl, ≤6°C, Na ₂ S ₂ O ₃ if Cl present	14 Days (7 days for aromatics if unpreserved)
Base/Neutrals and Acids		625	8270	1L Amber Glass	≤6°C, Na ₂ S ₂ O ₃ if Cl present	7/40 Days
Base/Neutrals, Acids & Pesticides	525.2			1L Amber Glass	pH <HCl, sodium sulfite if Cl present	14/30 Days
Diesel Range Organics			8015	1L Amber Glass	≤6°C, Na ₂ S ₂ O ₃ if Cl present	7/40 Days
Dioxins and Furans	1613B			1L Amber Glass	≤6°C, Na ₂ S ₂ O ₃ if Cl present	1 Year
Dioxins and Furans			8290	1L Amber Glass	≤6°C, Na ₂ S ₂ O ₃ if Cl present	30/45 Days
Dissolved Organic Carbon			Method 5310	250 ml Amber Glass	Field Filter from an Unpreserved Sample into an pH<2 H ₂ SO ₄ , ≤6°C	28 days
EDB & DBCP	504.1		8011	40mL vials	≤6°C, Na ₂ S ₂ O ₃ if Cl present	14 Days
Explosives			8330/8332	1L Amber Glass	≤6°C	7/40 Days
Gasoline Range Organics			8015	40mL vials	pH<2 HCl	14 Days
Haloacetic Acids	552.1/552.2			40mL Amber vials	NH ₄ Cl, ≤6°C	14/7 Days if extracts stored at ≤6°C or 14/14 Days if extracts stored at ≤-10°C
Herbicides, Chlorinated	515.1/515.3		8151	1L Amber Glass	≤6°C, Na ₂ S ₂ O ₃ if Cl present	7/40 Days for 8151; 14/28 Days for 515.1/515.3
PCBs, Organochlorine			8082	1L Amber Glass	≤6°C; Na ₂ S ₂ O ₃ if Cl present	1 Year/1Year
PCBs & Pesticides, Organochlorine		608		1L Amber Glass	≤6°C; Na ₂ S ₂ O ₃ if Cl present	7/40 Days
Pesticides, Organochlorine			8081	1L Amber Glass	≤6°C, Na ₂ S ₂ O ₃ if Cl present	7/40 Days
Pesticides, Organophosphorus			8141	1L Amber Glass	pH 5-8 with NaOH or H ₂ SO ₄ ; ≤6°C, Na ₂ S ₂ O ₃ if Cl Present	7/40 Days
Polynuclear Aromatic Hydrocarbons			8270 SIM	1L Amber Glass	≤6°C, Na ₂ S ₂ O ₃ if Cl present	7/40 Days
Volatiles		624	8260	3 - 40mL vials	pH<2 HCl; ≤6°C	14 Days (7 Days for aromatics if unpreserved)
Volatiles (see note 1)	524.2			40mL vials (in duplicate)	pH<2 HCl, ≤6°C, Na ₂ S ₂ O ₃ if Cl present	14 Days

¹ Method 524.2 lists ascorbic acid as the preservative when residual chlorine is suspected, unless gases or Table 7 compounds are NOT compounds of interest and then sodium thiosulfate is the preservative recommended.



**SOP-SA-02;
SAMPLE PRESERVATION AND
CONTAINERIZATION FOR
AQUEOUS SAMPLES**

**DATE ISSUED:
05/28/2015
REVISION: 0
PAGE 3 of 8**

Inorganic Parameters in Aqueous Samples

Parameter	Method			Container	Preservative	Max Hold Time
	EPA Water	Standard Methods	EPA Waste SW-846			
Acidity		SM2310B		Plastic/Glass	≤6°C	14 Days
Alkalinity	310.2	SM2320B		Plastic/Glass	≤6°C	14 Days
Anions by IC, including Br, Cl, F, NO ₂ , NO ₃ , o-Phos, SO ₄ , bromate, chlorite, chlorate)	300.0			Plastic/Glass	≤6°C	All analytes 28 days except NO ₂ , NO ₃ , o-Phos (48 hours); chlorite (immediate); NO ₂ /NO ₃ combo 28 days
Bacteria, Total Plate Count		SM9221D		Plastic/WK	≤6°C, Na ₂ S ₂ O ₃	24 Hours
BOD/cBOD		SM5210B/Hach 10360		Plastic/Glass	≤6°C	48 hours
Chloride		SM4500Cl-C,E		Plastic/Glass	None	28 Days
Chlorine, Residual	330.5	SM4500Cl-D, E, G / Hach 8167		Plastic/Glass	None	15 minutes
COD	410.4	SM5220C, D / Hach 8000		Plastic/Glass	pH<2 H ₂ SO ₄ , ≤6°C	28 Days
Color		SM2120B,E		Covered Plastic, Acid Washed Amber Glass	≤6°C	24 Hours
Cyanide, Reactive			Chapter 7	Plastic/Glass	None	28 Days
Cyanide, Total and Amenable	335.4	SM4500CN-A,B,C,D,E,G,I,N	9010/9012	Plastic/Glass	pH>12 NaOH; ≤6°C ascorbic acid if Cl present	14 Days (24 hrs if sulfide present - applies to SM4500CN only)
Ferrous Iron		SM3500Fe-D		Glass	None	Immediate
Flashpoint/Ignitability			1010	Plastic/Glass	None	28 Days
Fluoride		SM4500F-C,D		Plastic	None	28 Days
Hardness, Total (CaCO ₃)	130.1	SM2340B,C		Plastic/Glass	pH<2 HNO ₃	6 Months
Hexavalent Chromium	218.6	SM3500Cr-C,D	7196	Plastic/Glass	≤6°C	24 Hours, unless preserved per method, then 28 Days
Mercury	245.1/245.2		7470	Plastic/Glass	pH<2 HNO ₃	28 Days
Mercury, Low Level	1631E			Fluoropolymer (Glass if Hg is only analyte being tested)	12N HCl or BrCl	48 hours for preservation or analysis; 28 days to preservation if sample oxidized in bottle; 90 days for analysis if preserved
Metals (ICP/ICPMS)	200.7/200.8		6010/6020	Plastic/Glass	pH<2 HNO ₃	6 Months
Nitrogen, Ammonia	350.1	SM4500NH3		Plastic/Glass	pH<2 H ₂ SO ₄ , ≤6°C	28 Days
Nitrogen, Kjeldahl	351.2	SM4500-Norg		Plastic/Glass	pH<2 H ₂ SO ₄ , ≤6°C	28 Days
Nitrogen, Nitrate	352.1	SM4500-NO3		Plastic/Glass	≤6°C	48 Hours
Nitrogen, Nitrate & Nitrite, combined	353.2	SM4500-NO3		Plastic/Glass	pH<2 H ₂ SO ₄ , ≤6°C	28 Days
Nitrogen, Organic	351.2 / 350.1	SM4500-Norg		Calculation	pH<2 H ₂ SO ₄ , ≤6°C	28 Days
Odor		SM2150B		Glass	≤6°C	24 Hours
Oil and Grease/HEM	1664A	SM5520B	9070	Glass	pH<2 H ₂ SO ₄ or HCl, ≤6°C	28 Days
Oxygen, Dissolved (Probe)		SM4500-O		Glass	None	15 minutes
Paint Filter Liquid Test.			9095	Plastic/Glass	None	N/A



**SOP-SA-02;
SAMPLE PRESERVATION AND
CONTAINERIZATION FOR
AQUEOUS SAMPLES**

**DATE ISSUED:
05/28/2015
REVISION: 0
PAGE 4 of 8**

Inorganic Parameters in Aqueous Samples (Cont.)

Parameter	Method			Container	Preservative	Max Hold Time
	EPA Water	Standard Methods	EPA Waste SW-846			
Phenol, Total	420.1/420.4		9065/9066	Glass	pH<2 H ₂ SO ₄ , ≤6°C	28 Days
Phosphorus, Orthophosphate	365.1/365.3	SM4500P		Plastic	Filter, ≤6°C	Filter within 15 minutes, Analyze within 48 hours
Phosphorus, Total	365.1 / 365.3 / 365.4	SM4500P		Plastic/Glass	pH<2 H ₂ SO ₄ , ≤6°C	28 Days
Silica, Dissolved		SM4500Si-D		Plastic	≤6°C	28 Days
Solids, Settleable		SM2540F		Glass	≤6°C	48 Hours
Solids, Total		SM2540B		Plastic/Glass	≤6°C	7 Days
Solids, Total Dissolved		SM2540C		Plastic/Glass	≤6°C	7 Days
Solids, Total Suspended	USGS I-3765-85	SM2540D		Plastic/Glass	≤6°C	7 Days
Specific Conductance	120.1	SM2510B	9050	Plastic/Glass	≤6°C	28 Days
Sulfate	375.2	SM4500S04 / ASTM D516	9036/9038	Plastic/Glass	≤6°C	28 Days
Sulfide, Reactive			Chapter 7	Plastic/Glass	None	28 Days
Sulfide, Total		SM4500S	9030	Plastic/Glass	pH>9 NaOH and ZnOAc; ≤6°C	7 Days
Sulfite		SM4500SO3		Plastic/Glass	None	15 minutes
Surfactants (MBAS)		SM5540C		Plastic/Glass	≤6°C	48 Hours
Total Organic Carbon (TOC)		SM5310B,C,D	9060	Glass	pH<2 H ₂ SO ₄ or HCl, ≤6°C	28 Days
Total Organic Halogen (TOX)		SM5320	9020/9021	Glass (No headspace)	pH<2 H ₂ SO ₄ , ≤6°C	14 Days
Turbidity	180.1	SM2130B		Plastic/Glass	≤6°C	48 Hours

² Methods 9315 and 9320 both state that if samples are unpreserved, the samples should be brought to the lab within 5 days of collection, preserved in the lab, and then allowed to sit for a minimum of 16 hours before sample preparation/analysis.

RADCHEM PARAMETERS

Parameter	Method			Container	Preservative	Max Hold Time
	EPA Water	Standard Methods	EPA SW-846			
Gamma Emitting Radionuclides (see note 2)	901.1			Plastic/Glass	pH<2 HNO ₃	180 days
Gross Alpha (NJ 48Hr Method)	NJAC 7:18-6			Plastic/Glass	pH<2 HNO ₃	48 hours
Gross Alpha and Gross Beta (see note 2)	900.0		9310	Plastic/Glass	pH<2 HNO ₃	180 days
Radium-226 (see note 2)	903.0/903.1			Plastic/Glass	pH<2 HNO ₃	180 days
Radium-228 (see note 2)	904.0		9320	Plastic/Glass	pH<2 HNO ₃	180 days
Radioactive Strontium (see note 2)	905.0			Plastic/Glass	pH<2 HNO ₃	180 days
Total Alpha Radium (see note 2)	903.0		9315	Plastic/Glass	pH<2 HNO ₃	180 days
Total Uranium (see note 2)	908.0	D5174-97		Plastic/Glass	pH<2 HNO ₃	180 days
Tritium	906.0			Glass	None	180 Days

² Methods 9315 and 9320 both state that if samples are unpreserved, the samples should be brought to the lab within 5 days of collection, preserved in the lab, and then allowed to sit for a minimum of 16 hours before sample preparation/analysis.



**SOP-SA-02;
SAMPLE PRESERVATION AND
CONTAINERIZATION FOR
AQUEOUS SAMPLES**

DATE ISSUED:
05/28/2015
REVISION: 0
PAGE 5 of 8

HSSE CONSIDERATIONS				
This section to be completed with concurrence from the Safety and Health Manager.				
<i>SOURCE</i>	<i>HAZARDS</i>	<i>WHERE</i>	<i>HOW, WHEN, RESULT</i>	<i>CONTROLS</i>
CHEMICAL	<p>Potential contact with contaminated water samples.</p> <p>Preservatives (HCL, HNO₃, H₂SO₄, NaOH and Na₂S₂O₃).</p>	<p>Sites.</p> <p>In bottles or added to bottles through sampling process.</p>	<p>Inadvertent exposure to contaminated water samples could lead to adverse health effects.</p> <p>Inadvertent exposure to preservatives could lead to adverse health effects.</p>	<p>Personnel will practice proper personal hygiene – wash hands prior to eating/drinking and when leaving the site. Employees will wear nitrile gloves and safety glasses when handling sample containers.</p> <p>Safety Data Sheets for each preservative chemical are available to all employees on the Pioneer company web site. Personnel will wear nitrile gloves and safety glasses when using preservatives and when handling the bottles. Refer to the Chemical Flushing Guidelines available inside vehicle's first aid kit for first-aid procedures in case of contact with preservatives.</p>
NOISE	Not applicable.			
ELECTRICAL	Not applicable.			
BODY MECHANICS	Improper lifting.	Sites.	Back injuries and muscle/back strains could result when using improper techniques to lift and carry coolers with samples.	Personnel will use proper lifting techniques – get a good grip, keep the load close to the body, lift with legs and not with back, and avoid lifting loads above shoulder's height. Two workers will lift/carry the coolers, if needed.
GRAVITY	Falls from slips and trips.	Uneven terrain, slick/muddy/wet surfaces and steep slopes.	Walking/working on slick/muddy/wet and uneven terrain could cause slips and trips resulting in falls and injuries.	Personnel will wear work boots with good traction and ankle support. Personnel will be aware of working/walking surfaces and choose a path to avoid hazards. Keep work areas as dry as possible. Wear muck boots, as necessary.



**SOP-SA-02;
SAMPLE PRESERVATION AND
CONTAINERIZATION FOR
AQUEOUS SAMPLES**

DATE ISSUED:
05/28/2015
REVISION: 0
PAGE 6 of 8

WEATHER	Cold/heat stress.	Sites.	Exposure to cold climates may result in cold burns, frostbites, and hypothermia. Exposure to high temperatures may result in heat cramps, heat exhaustion, or heat stroke.	Training on signs and symptoms of cold/heat stress is required. Personnel will wear appropriate clothing when working outdoors. Personnel will remain hydrated and will have sufficient caloric intakes during the day. Personnel will follow procedures outlined in applicable SSHASP and/or Pioneer corporate HASP.
	Lightning.	Outdoor sites.	Electrocution, injury, death, or equipment damage could be caused by lightning strike.	Employees will follow the 30/30 rule during lightning storms.
RADIATION	Ultraviolet (UV) radiation.	Outdoors.	Employees could be exposed to UV radiation during summer months causing sun burns, skin damage, and eye damage.	Employees will wear safety glasses with tinted lenses, long-sleeve work shirts, and long pants. Employees should wear sunscreen, if necessary.
BIOLOGICAL	Plants, insects, and animals.	Outdoors.	Exposure to plants, insects, and/or animals may cause rashes, blisters, redness, and swelling.	Training on the signs and symptoms of exposure to plants, insects, and animals is required. Avoid contact with plants, insects, and animals. First-aid kits will be available on site. Employees with allergies will notify their supervisor.
MECHANICAL	Not applicable.			
PRESSURE	Not applicable.			
THERMAL	Not applicable.			
HUMAN FACTORS	Inexperienced and improperly trained worker.	Sites.	Inexperienced workers and improper training could	Employees will be properly trained in this procedure and other applicable procedures. Employees will implement



**SOP-SA-02;
SAMPLE PRESERVATION AND
CONTAINERIZATION FOR
AQUEOUS SAMPLES**

DATE ISSUED:
05/28/2015
REVISION: 0
PAGE 7 of 8

			cause incidents resulting in adverse health effects and/or property damage.	stop work procedures, if necessary.
SIMOPS	Not applicable.			

ADDITIONAL HSSE CONSIDERATIONS

This section to be completed with concurrence from the Safety and Health Manager.

REQUIRED PPE	Hard hat, safety glasses, high-visibility work shirt or vest, long pants, work boots, and nitrile gloves.
APPLICABLE SDS	HCL, HNO ₃ , H ₂ SO ₄ , NaOH and Na ₂ S ₂ O ₃ . Additional Safety Data Sheets (SDSs) will be maintained based on site characterization and contaminants.
REQUIRED PERMITS/FORMS	Per site/project requirements.
ADDITIONAL TRAINING	Per site/project requirements.

DRAWINGS, DOCUMENTS, AND TOOLS/EQUIPMENT

The following documents should be referenced to assist in completing the associated task.

P&IDS	
DRAWINGS	
RELATED SOPs/PROCEDURES/ WORK PLANS	SOP-SA-01 Soil and Water Sample Packaging and Shipping.
TOOLS	Preservatives, sample container, ice, and cooler.
FORMS/CHECKLIST	





**SOP-SA-02;
SAMPLE PRESERVATION AND
CONTAINERIZATION FOR
AQUEOUS SAMPLES**

DATE ISSUED:
05/28/2015
REVISION: 0
PAGE 8 of 8

APPROVALS/CONCURRENCE

By signing this document, all parties acknowledge the completeness and applicability of this SOP for its intended purpose. Also, by signing this document, it serves as acknowledgement that I have received training on the procedure and associated competency testing.

SOP TECHNICAL AUTHOR	DATE
 Julie Flammang	05/28/2015
SAFETY AND HEALTH MANAGER	DATE
 Tara Schleeman	05/28/2015

Revisions:

Revision	Description	Date



SOP-SA-03A
FIELD QUALITY CONTROL
SAMPLES FOR WATER
SAMPLING

AUTHORIZED
VERSION:
 09/29/2020
 PAGE 1 of 6

PURPOSE	This Standard Operating Procedure (SOP) describes the preparation and collection frequency of field quality control (QC) blanks and duplicate samples from water media.
SCOPE	Pioneer Technical Services, Inc. (Pioneer) prepared this practice for the workforce and this SOP applies to all work performed by and on behalf of Pioneer. All members of the Pioneer workforce who conduct the work shall be trained and competent (as defined by OSHA) in the risk-assessed procedure described below before performing the work.

WORK INSTRUCTIONS

The following instructions provide guidance to perform the task in a safe, accurate, and reliable manner. If these instructions present information that is inaccurate or unsafe, personnel must notify the Project Manager, Safety Manager, and the SOP Technical Author to initiate appropriate revisions. Personnel will perform all work under this SOP in a manner that is consistent with procedures and policies described in the appropriate Operation, Maintenance, and Monitoring (O&M) Plan (where applicable), appropriate Site-Specific Health and Safety Plans (SSHASP), and Pioneer Corporate Health and Safety Plan (HASP).

TASK	INSTRUCTIONS
Field Quality Control	<p>At least one set of field QC samples will be prepared for each sampling event or as detailed in the project-specific Sampling and Analysis Plan (SAP) or Quality Assurance Project Plan (QAPP).</p> <p>The QC samples will be collected at a frequency of 1:20 or as detailed in the project-specific SAP or QAPP. If the number of field QC samples taken is not equal to an integer multiple of 20 or the interval specified in the SAP/QAPP, the next higher multiple will be used. For example, if a frequency of 1:20 is indicated and 28 samples are taken, 2 QC samples will be prepared.</p> <p>All field QC samples will be shipped with field samples to the contract laboratory as per SOP-SA-01 Soil and Water Sample Packaging and Shipping.</p>
Field Blank or Bottle Blank	<p>A minimum of 1 field bottle blank is required for every 20 natural samples.</p> <p>A bottle blank is a sample bottle containing deionized or analyte free water and preservatives and is prepared in the field. A sample bottle is randomly chosen from each lot of bottles received by the contract laboratory or supplier and deionized or analyte free water (depending on the analysis requested) is poured directly into the sample bottle while in the field and the bottle is preserved and shipped to the laboratory with the field samples.</p> <p>The field blank must be prepared in the field to evaluate the potential for contamination of a sample by site contaminants from sources not associated with the sample collected (e.g., air-borne dust). The appropriate sample number will be placed on the bottle and recorded in the project logbook as a bottle blank.</p>



SOP-SA-03A
FIELD QUALITY CONTROL
SAMPLES FOR WATER
SAMPLING

AUTHORIZED
VERSION:
 09/29/2020
 PAGE 2 of 6

<p>Trip Blank</p>	<p>One trip blank should be included in each cooler shipped when volatile organic compound (VOC) or volatile petroleum hydrocarbon (VPH) samples are collected.</p> <p>Trip blanks are used to determine if samples are contaminated during storage and/or transportation back to the laboratory. A trip blank is only required for VOC/VPH samples. Trip blanks are prepared for field personnel by the contract laboratory staff prior to the sampling event and are shipped and stored in the same coolers with the investigative VOC/VPH samples throughout the sampling event. At no time after their preparation are trip blanks to be opened before they reach the laboratory. Trip blanks should be kept on ice in the cooler, along with the VOC/VPH samples during the entire sampling run. They must be stored in an iced cooler from the time of collection, while they are in the sampling vehicle, and until they arrive at the laboratory.</p> <p>Note: If trip blanks are received from the laboratory with air bubbles in them NOTIFY the team leader or project manager and have the laboratory send new trip blanks prior to the sampling event.</p>
<p>Equipment, Cross Contamination, or Rinsate Blank</p>	<p>A minimum of 1 equipment blank is required for every 20 natural samples.</p> <p>Equipment blanks are collected after the completion of decontamination of sampling equipment and prior to sampling. An equipment blank is prepared by running distilled, deionized, or analyte free water through or over the cleaned sampling equipment and adding the appropriate chemical preservatives. Equipment blanks are generally prepared in the field. One equipment blank at a minimum must be prepared for each type of preservative and for any filtered samples. Equipment blanks will assess the adequacy of the decontamination process as well as the potential contamination of samples by the containers, preservatives, and filters. The appropriate sample number will be placed on the bottle and recorded in the project logbook as equipment blank.</p>
<p>Field Duplicate</p>	<p>A minimum of 1 duplicate is required for every 20 natural samples.</p> <p>A field duplicate is defined as a second sample, from the same location, collected in immediate succession, using identical techniques. This applies to all routine surface and groundwater collection procedures, including in-stream grab samples, bucket grab samples (e.g., from bridges), pumps, and other water sampling devices.</p> <p>Duplicate samples are sealed, handled, stored, shipped, and analyzed in the same manner as the primary sample. Duplicates should be submitted as “blind” meaning that the duplicate sample is given a separate sample identification number, so it is not identified with the primary sample. Field duplicates assess sampling precision.</p>



SOP-SA-03A
FIELD QUALITY CONTROL
SAMPLES FOR WATER
SAMPLING

AUTHORIZED
VERSION:
 09/29/2020
 PAGE 3 of 6

Temperature Blank	<p>One temperature blank is required for each cooler shipped.</p> <p>A temperature blank is a vial of tap or deionized water placed in each cooler that will be opened and tested upon arrival at the laboratory to ensure that the temperature of the contents of the sample shipping containers are within the required $4\text{ }^{\circ}\text{C} \pm 2^{\circ}$.</p>
--------------------------	---

HEALTH SAFETY SECURITY ENVIRONMENT (HSSE) CONSIDERATIONS

This section to be completed with concurrence from the Safety and Health Manager.

<i>SOURCE</i>	<i>HAZARDS</i>	<i>WHERE</i>	<i>HOW, WHEN, RESULT</i>	<i>CONTROLS</i>
CHEMICAL	Potential contact with contaminated water samples.	Sites.	Inadvertent exposure to contaminated water samples could lead to adverse health effects.	Personnel will practice proper personal hygiene – wash hands prior to eating/drinking and when leaving the site. Personnel will wear nitrile gloves and safety glasses when handling sample containers.
	Preservatives (HCL, HNO ₃ , H ₂ SO ₄ , Zinc, Acetate, and NaOH).	In bottles or added to bottles through sampling process.	Inadvertent exposure to preservatives could lead to adverse health effects.	Safety Data Sheets for each preservative chemical are available to all personnel and are located on the Pioneer company web site. Personnel will wear nitrile gloves and safety glasses when using preservatives and when handling the bottles. Refer to the Chemical Flushing Guidelines available inside vehicle's first aid kit for first-aid procedures in case of contact with preservatives.
NOISE	Not applicable.			
ELECTRICAL	Not applicable.			
BODY MECHANICS	Improper lifting.	Sites.	Back injuries and muscle/back strains could result when using improper techniques to lift and carry packaged samples and coolers.	Personnel will use proper lifting techniques – get a good grip, keep the load close to the body, lift with legs and not with back, and avoid lifting loads above shoulder's height. Two workers will lift/carry packaged samples and coolers, if needed.



SOP-SA-03A
FIELD QUALITY CONTROL
SAMPLES FOR WATER
SAMPLING

AUTHORIZED
VERSION:
 09/29/2020
 PAGE 4 of 6

HEALTH SAFETY SECURITY ENVIRONMENT (HSSE) CONSIDERATIONS

This section to be completed with concurrence from the Safety and Health Manager.

<i>SOURCE</i>	<i>HAZARDS</i>	<i>WHERE</i>	<i>HOW, WHEN, RESULT</i>	<i>CONTROLS</i>
GRAVITY	Falls from slips and trips.	Uneven terrain, slick/muddy/wet surfaces and steep slopes.	Walking/working on slick/muddy/wet and uneven terrain could cause slips and trips resulting in falls and injuries.	Personnel will wear work boots with good traction and ankle support. Personnel will be aware of working/walking surfaces and choose a path to avoid hazards. Keep work areas as dry as possible. Wear muck boots, as necessary.
WEATHER	Cold/heat stress. Lightning.	Sites. Outdoor sites.	Exposure to cold climates may result in cold burns, frostbites, and hypothermia. Exposure to high temperatures may result in heat cramps, heat exhaustion, or heat stroke. Electrocution, injury, death, or equipment damage could be caused by lightning strike.	Training on signs and symptoms of cold/heat stress is required. Personnel will wear appropriate clothing when working outdoors. Personnel will remain hydrated and will have sufficient caloric intakes during the day. Personnel will follow procedures outlined in applicable SSHASP and/or Pioneer corporate HASP. Personnel will follow the 30/30 rule during lightning storms.
RADIATION	Ultraviolet (UV) radiation.	Outdoors.	Personnel could be exposed to UV radiation during summer months causing sun burns, skin damage, and eye damage.	Personnel will wear safety glasses with tinted lenses, long-sleeve work shirts, and long pants. Personnel should wear sunscreen, if necessary.
BIOLOGICAL	Plants, insects, and animals.	Outdoors.	Exposure to plants, insects, and/or animals may cause rashes, blisters, redness, and swelling.	Training on the signs and symptoms of exposure to plants, insects, and animals is required. Avoid contact with plants, insects, and animals. First-aid kits will be available on site. Personnel with allergies will notify their supervisor.



SOP-SA-03A
FIELD QUALITY CONTROL
SAMPLES FOR WATER
SAMPLING

AUTHORIZED
VERSION:
 09/29/2020
 PAGE 5 of 6

HEALTH SAFETY SECURITY ENVIRONMENT (HSSE) CONSIDERATIONS

This section to be completed with concurrence from the Safety and Health Manager.

<i>SOURCE</i>	<i>HAZARDS</i>	<i>WHERE</i>	<i>HOW, WHEN, RESULT</i>	<i>CONTROLS</i>
MECHANICAL	Not applicable.			
PRESSURE	Not applicable.			
THERMAL	Not applicable.			
HUMAN FACTORS	Inexperienced and improperly trained personnel.	Sites.	Inexperienced personnel and improper training could cause incidents resulting in adverse health effects and/or property damage.	Personnel will be properly trained in this procedure and other applicable procedures. Personnel will implement stop work procedures, if necessary.
SIMOPS (Simultaneous Operations)	Not applicable.			

ADDITIONAL HSSE CONSIDERATIONS

This section to be completed with concurrence from the Safety and Health Manager.

REQUIRED PPE	Personal Protection Equipment (PPE): Safety glasses, high-visibility work shirt or vest, long pants, work boots, and nitrile gloves.
APPLICABLE SDSs	Safety Data Sheets (SDS): HCL, HNO ₃ , H ₂ SO ₄ , Zinc, Acetate, and NaOH. Safety Data Sheets are available to Pioneer personnel at the link below: https://pioneertechnicalservices.sharepoint.com/Safety/SafetyDataSheets
REQUIRED PERMITS/ FORMS	Per site/project requirements.
ADDITIONAL TRAINING	Per site/project requirements.



**SOP-SA-03A
FIELD QUALITY CONTROL
SAMPLES FOR WATER
SAMPLING**

**AUTHORIZED
VERSION:
09/29/2020
PAGE 6 of 6**



DRAWINGS, DOCUMENTS, AND TOOLS/EQUIPMENT

The following documents should be referenced to assist in completing the associated task.

DRAWINGS	
RELATED SOPs/ PROCEDURES/ WORK PLANS	SOP-SA-01 Soil and Water Sample Packaging and Shipping.
TOOLS/ EQUIPMENT	Preservatives, sample glass bottles, ice, and cooler.
FORMS/ CHECKLIST	

APPROVALS/CONCURRENCE

By signing this document, all parties acknowledge the completeness and applicability of this SOP for its intended purpose. Also, by signing this document, it serves as acknowledgement that I have received training on the procedure and associated competency testing.

SOP TECHNICAL AUTHOR	DATE
 Julie Flammang	09/29/2020
SAFETY AND HEALTH MANAGER	DATE
 Tara Schleeman	09/29/2020



**SOP-SA-03B;
PREPARATION OF
EQUIPMENT RINSATE BLANKS
FOR SUBMERIBLE PUMPS**

DATE ISSUED:
05/28/2015
REVISION: 0
PAGE 1 of 6

PURPOSE	This SOP describes the preparation of Equipment Cross Contamination or Rinsate Blanks from a submersible pump.
SCOPE	This practice has been prepared for the Pioneer Technical Services, Inc. (Pioneer) workforce and applies to work carried out by and on behalf of Pioneer. All members of the Pioneer workforce who conduct the work shall be trained and competent in the risk-assessed work described below.

WORK INSTRUCTIONS

The following instructions are intended to provide sufficient guidance to perform the task in a safe, accurate, and reliable manner. Should these instructions present information that is inaccurate or unsafe, operations personnel must bring the issue to the attention of the Project Manager and the appropriate revisions made. All work carried under this SOP will be consistent with procedures and policies described in the appropriate Operation, Maintenance, and Monitoring (O&M) Plan (where applicable), appropriate Site-Specific Health and Safety Plan (SSHASP), and Pioneer Corporate Health and Safety Plan (HASP).

TASK	INSTRUCTIONS
-------------	---------------------

Notes:

Equipment blanks, also known as rinsate blanks, are collected periodically after completing decontamination of sampling equipment and prior to resuming sampling. Equipment blanks assess the adequacy of the decontamination process and the potential contamination of samples by the containers, preservatives, and filters. Consequently, an equipment blank may be made of a single or multiple sample containers that represent the natural sampling process.

A minimum of one equipment blank is required for every 20 natural samples, regardless of the pump type used. Blanks are collected by running de-ionized or analyte free water through or over the cleaned sampling equipment and adding the appropriate chemical preservative. Field equipment rinsates should be collected in an environment free from dust and automobile exhaust. A separate blank must be collected for each type of preservative (e.g., HCl, HNO₃, H₂SO₄, NaOH, etc.) used and each sample preparation method (e.g., unfiltered or filtered) used. If more than one type of pump is used for sampling (e.g., peristaltic pump, 12-volt submersible pump, Grunfoss Redi-Flo II pump, etc.), equipment blanks should be collected from the pump type used to collect the majority of samples, unless project-specific requirements differ. The following examples demonstrate how the number of equipment blanks may be determined.

Example #1: A project requires 14 samples to be collected using a peristaltic pump and 5 samples to be collected using a 12-volt submersible pump. There are no project-specific equipment blank requirements. Only 1 equipment blank is necessary because less than 20 natural samples will be collected. The equipment blank should be collected from the peristaltic pump because it was used to collect a majority of the natural samples.

Example #2: A project requires 23 samples to be collected using a 12-volt submersible pump, 5 samples to be collected using a Grunfoss Redi-Flow II pump, and 19 samples to be collected using a peristaltic pump. There are no project-specific equipment blank requirements. A minimum of 3 equipment blanks must be collected because the total number of natural samples is greater than 40. To evaluate potential cross contamination from each piece of sampling equipment, 1 equipment blank should be collected from each of the 3 pumps.



**SOP-SA-03B;
PREPARATION OF
EQUIPMENT RINSATE BLANKS
FOR SUBMERIBLE PUMPS**

DATE ISSUED:
05/28/2015
REVISION: 0
PAGE 2 of 6

Prior to starting the fieldwork, personnel should review the anticipated sampling conditions (e.g., well diameter, depth to water, historic contamination levels, etc.) to determine the likely number of equipment blanks. However, once in the field, personnel should be aware of conditions that may require adjustments to the number of equipment blanks (e.g., inaccurate well construction details, changes in water level, historic contamination, etc.).

1. Label blank container.	Label sample containers with the appropriate sample number as designated in the Sampling and Analysis Plan (SAP) or Quality Assurance Project Plan (QAPP). Place clear tape over the sample label. All sample containers collected for a natural sample should be duplicated for an equipment blank.
2. Blank container preparation.	Prepare the equipment blank container by removing the covering and rinsing with de-ionized (DI) water. Before a sampling event where more than one or two wells will be sampled, a new container for collecting equipment blanks should be prepared by triple rinsing with DI water and covering with foil or plastic. The container should be tall enough to submerge the pump and have a wide enough mouth that additional water can easily be added.
3. Remove pump.	Don a new pair of nitrile gloves and remove a decontaminated pump from its storage container making sure that the attached tubing (if appropriate) and pump do not contact any other surface (i.e., the ground). If needed attach a short piece of tubing to the pump.
4. Fill rinsate container.	Place the pump in the container dedicated for equipment blanks. A fresh jug of DI water should be opened and poured into the container to cover the pump.
5. Purge and collect samples.	Turn the pump on and continue to pour DI water into the container. Purge a minimum of 4 gallons through the pump as this simulates the purging done when sampling a well. Once an appropriate volume of water has been discharged from the pump, fill sample containers in the same order and method that they are filled when collecting a natural sample. If filtered samples are collected for field samples, a filter should be inserted into the discharge tube after all non-filtered samples have been collected and the appropriate sample containers should be filled.
6. Record in logbook.	The sample number and a description of the collection process should be recorded in the project logbook. The sample should be clearly identified in the logbook as an equipment blank.
7. Place on ice.	The sample containers should be placed in a cooler on ice as soon as possible after collection.
8. Empty and cover rinsate container.	Empty water out of dedicated equipment rinsate container and cover the container to avoid inadvertently contaminating the interior prior to the next blank sample.



**SOP-SA-03B;
PREPARATION OF
EQUIPMENT RINSATE BLANKS
FOR SUBMERIBLE PUMPS**

DATE ISSUED:
05/28/2015
REVISION: 0
PAGE 3 of 6

HSSE CONSIDERATIONS				
This section to be completed with concurrence from the Safety and Health Manager.				
<i>SOURCE</i>	<i>HAZARDS</i>	<i>WHERE</i>	<i>HOW, WHEN, RESULT</i>	<i>CONTROLS</i>
CHEMICAL	<p>Potential contact with contaminated water samples.</p> <p>Preservatives (HCL, HNO₃, H₂SO₄, Zinc, Acetate, and NaOH).</p>	<p>Sites.</p> <p>In bottles or added to bottles through sampling process.</p>	<p>Inadvertent exposure to contaminated water samples could lead to adverse health effects.</p> <p>Inadvertent exposure to preservatives could lead to adverse health effects.</p>	<p>Personnel will practice proper personal hygiene – wash hands prior to eating/drinking and when leaving the site. Employees will wear nitrile gloves and safety glasses when handling sample containers.</p> <p>Safety Data Sheets for each preservative chemical are available to all employees on the Pioneer company web site. Personnel will wear nitrile gloves and safety glasses when using preservatives and when handling the bottles. Refer to the Chemical Flushing Guidelines available inside vehicle’s first aid kit for first-aid procedures in case of contact with preservatives.</p>
NOISE	Not applicable.			
ELECTRICAL	Not applicable.			
BODY MECHANICS	Improper lifting.	Sites.	Back injuries and muscle/back strains could result when using improper techniques to lift and carry packaged samples, coolers, and large containers of water.	Personnel will use proper lifting techniques – get a good grip, keep the load close to the body, lift with legs and not with back, and avoid lifting loads above shoulder’s height. Two workers will lift/carry packaged samples, coolers and large containers of water, if needed.
GRAVITY	Falls from slips and trips.	Uneven terrain, slick/muddy/wet surfaces and steep slopes.	Walking/working on slick/muddy/wet and uneven terrain could	Workers will wear work boots with good traction and ankle support. Workers will be aware of working/walking surfaces and choose a path to avoid



**SOP-SA-03B;
PREPARATION OF
EQUIPMENT RINSATE BLANKS
FOR SUBMERIBLE PUMPS**

DATE ISSUED:
05/28/2015
REVISION: 0
PAGE 4 of 6

			cause slips and trips resulting in falls and injuries.	hazards. Keep work areas as dry as possible. Wear muck boots, as necessary.
WEATHER	Cold/heat stress.	Sites.	Exposure to cold climates may result in cold burns, frostbites, and hypothermia. Exposure to high temperatures may result in heat cramps, heat exhaustion, or heat stroke.	Training on signs and symptoms of cold/heat stress is required. Personnel will wear appropriate clothing when working outdoors. Personnel will remain hydrated and will have sufficient caloric intakes during the day. Personnel will follow procedures outlined in applicable SSHASP and/or Pioneer corporate HASP.
	Lightning.	Outdoor sites.	Electrocution, injury, death, or equipment damage could be caused by lightning strike.	Employees will follow the 30/30 rule during lightning storms.
RADIATION	Ultraviolet (UV) radiation.	Outdoors.	Employees could be exposed to UV radiation during summer months causing sun burns, skin damage, and eye damage.	Employees will wear safety glasses with tinted lenses, long-sleeve work shirts, and long pants. Employees should wear sunscreen, if necessary.
BIOLOGICAL	Plants, insects, and animals.	Outdoors.	Exposure to plants, insects, and/or animals may cause rashes, blisters, redness, and swelling.	Training on the signs and symptoms of exposure to plants, insects, and animals is required. Avoid contact with plants, insects, and animals. First-aid kits will be available on site. Employees with allergies will notify their supervisor.
MECHANICAL	Not applicable.			
PRESSURE	Not applicable.			
THERMAL	Not applicable.			



**SOP-SA-03B;
PREPARATION OF
EQUIPMENT RINSATE BLANKS
FOR SUBMERIBLE PUMPS**

DATE ISSUED:
05/28/2015
REVISION: 0
PAGE 5 of 6

HUMAN FACTORS	Inexperienced and improperly trained worker.	Sites.	Inexperienced workers and improper training could cause incidents resulting in adverse health effects and/or property damage.	Employees will be properly trained in this procedure and other applicable procedures. Employees will implement stop work procedures, if necessary.
SIMOPS	Not applicable.			

ADDITIONAL HSSE CONSIDERATIONS

This section to be completed with concurrence from the Safety and Health Manager.

REQUIRED PPE	Hard hat, safety glasses, high-visibility work shirt or vest, long pants, work boots, and nitrile gloves.
APPLICABLE SDS	HCL, HNO ₃ , H ₂ SO ₄ , Zinc, Acetate, and NaOH. Additional Safety Data Sheets (SDSs) will be maintained based on site characterization and contaminants.
REQUIRED PERMITS/FORMS	Per site/project requirements.
ADDITIONAL TRAINING	Per site/project requirements.

DRAWINGS, DOCUMENTS, AND TOOLS/EQUIPMENT

The following documents should be referenced to assist in completing the associated task.

P&IDS	
DRAWINGS	
RELATED SOPs/PROCEDURES/WORK PLANS	SOP-SA-01 Soil and Water Sample Packaging and Shipping.
TOOLS	Preservatives, sample bottles, pumps, dedicated rinsate containers, DI water, ice, nitrile gloves, and cooler.
FORMS/CHECKLIST	





**SOP-SA-03B;
PREPARATION OF
EQUIPMENT RINSATE BLANKS
FOR SUBMERIBLE PUMPS**

DATE ISSUED:
05/28/2015
REVISION: 0
PAGE 6 of 6

APPROVALS/CONCURRENCE

By signing this document, all parties acknowledge the completeness and applicability of this SOP for its intended purpose. Also, by signing this document, it serves as acknowledgement that I have received training on the procedure and associated competency testing.

SOP TECHNICAL AUTHOR	DATE
 Julie Flammang	05/28/2015
SAFETY AND HEALTH MANAGER	DATE
 Tara Schleeman	05/28/2015

Revisions:

Revision	Description	Date



SOP-SA-04
CHAIN OF CUSTODY FORMS
FOR ENVIRONMENTAL
SAMPLES

AUTHORIZED
VERSION:
 11/12/2020
 PAGE 1 of 7

PURPOSE	This Standard Operating Procedure (SOP) establishes the requirements for documenting and maintaining environmental sample chain of custody from point of origin to receipt of sample at the analytical laboratory. This procedure will apply to all types of air, soil, water, sediment, biological, and/or core samples collected in environmental investigations by Pioneer Technical Services, Inc. (Pioneer). It is applicable from the time of sample acquisition until custody of the sample is transferred to an analytical laboratory.
SCOPE	Pioneer prepared this practice for the workforce and this SOP applies to all work performed by and on behalf of Pioneer. All members of the Pioneer workforce who conduct the work shall be trained and competent (as defined by OSHA) in the risk-assessed procedure described below before performing the work.
DEFINITIONS	<p>Chain of custody is an unbroken trail of accountability that ensures the physical security of samples, data, and records. Custody refers to the physical responsibility for sample integrity, handling, and/or transportation. Custody responsibilities are effectively met, if the samples are:</p> <ul style="list-style-type: none"> • In the responsible individual's physical possession; • In the responsible individual's visual range after having taken possession; • Secured by the responsible individual so that no tampering can occur (usually for shipping); or • Secured or locked by the responsible individual in an area in which access is restricted to authorized personnel only.
WORK INSTRUCTIONS	
<p>The following instructions provide guidance to perform the task in a safe, accurate, and reliable manner. If these instructions present information that is inaccurate or unsafe, personnel must notify the Project Manager, Safety Manager, and the SOP Technical Author to initiate appropriate revisions. Personnel will perform all work under this SOP in a manner that is consistent with procedures and policies described in the appropriate Operation, Maintenance, and Monitoring (O&M) Plan (where applicable), appropriate Site-Specific Health and Safety Plans (SSHASP), and Pioneer Corporate Health and Safety Plan (HASP).</p>	
TASK	INSTRUCTIONS
Project Manager's Responsibilities	The Project Manager is responsible for overall management of environmental sampling activities, designating sampling responsibilities to qualified personnel, and reviewing any changes to the sampling plan.
Field Team Leader's Responsibilities	<p>The Project Manager may act as the Field Team Leader or may choose to appoint a Field Team Leader.</p> <p>The Field Team Leader is responsible for general supervision of field sampling activities and ensuring proper storage/transportation of samples from the field to the analytical laboratory. The Field Team Leader is also responsible for maintaining sample custody as defined above until the sample has been properly relinquished as documented on the chain of custody form.</p>



SOP-SA-04
CHAIN OF CUSTODY FORMS
FOR ENVIRONMENTAL
SAMPLES

AUTHORIZED
VERSION:
 11/12/2020
 PAGE 2 of 7

	<p>The Field Team Leader will review chain of custody forms for accuracy and completeness to preserve sample integrity from collection to receipt by an analytical laboratory. The review of chain of custody forms may be delegated to qualified personnel.</p>
<p>Field Sampler's Responsibilities</p>	<p>The Field Sampler is responsible for sample acquisition in compliance with technical procedures, initiating the chain of custody, and checking sample integrity and documentation prior to transfer.</p> <p>Field samplers are also responsible for initial transfer of samples consisting of physical transfer of samples directly to the internal laboratory or transferred to a shipping carrier, (e.g., United Parcel Service or Federal Express) for delivery.</p>
<p>Laboratory Technician's Responsibilities</p>	<p>The receiving Laboratory Technician is responsible for inspecting transferred samples to ensure proper labeling and satisfactory sample condition.</p> <p>Unacceptable samples will be identified and segregated. The Laboratory Project Manager will be notified.</p> <p>The Laboratory Technician will review the chain of custody for completeness and file as part of the project's permanent record.</p>
<p>Fill out Chain of Custody Forms</p>	<p>The Field Team Leader or designated Field Sampler will initiate the chain of custody form for the initial transfer of samples.</p> <p>A chain of custody form will be completed and accompany every sample set. Only those samples included in the shipping container (cooler or box) should be listed on the chain of custody form included in the container. All chain of custody forms must be completed and include the following information:</p> <ul style="list-style-type: none"> • Project code. • Project name. • Sampler's signature. • Sample identification. • Date sampled. • Time sampled. • Analysis requested. • Remarks column should contain information about a sample that the laboratory might need. Examples of remarks that should be included: <ul style="list-style-type: none"> ▪ If samples could have very high or low expected concentrations (outside of normal instrument calibration range). ▪ DO NOT USE FOR QA/QC (quality assurance/quality control) should be indicated for field blanks, bottle blanks, or equipment rinsate blanks. ▪ If a sample should be held for later analysis (i.e., if sample being analyzed requires results from another sample to determine analysis status).



SOP-SA-04
CHAIN OF CUSTODY FORMS
FOR ENVIRONMENTAL
SAMPLES

AUTHORIZED
VERSION:
 11/12/2020
 PAGE 3 of 7

	<ul style="list-style-type: none"> ▪ The sample should be archived after initial analysis by the laboratory for potential additional analysis in the future. ▪ Requires filtering (if not completed in the field). ▪ Requires preservation (if not completed in the field). ▪ Any other sample specific information that will aid the laboratory in completing the appropriate analysis. <ul style="list-style-type: none"> • Relinquishing signature, data, and time. • Receiving signature, date, and time. <p>Laboratory-provided chain of custody forms should be used if provided, and all required fields should be filled out. Pioneer also has generic chain of custody forms that can be used if no laboratory forms are available. Make sure that the above required information is on the form and include the laboratory name and address to which the samples are being shipped.</p> <p>The Field Sampler relinquishing custody and the responsible individual accepting custody will sign, date, and note the time of transfer on the chain of custody form.</p> <p><u>Note:</u> if the transporter is not an employee of Pioneer, the Field Sampler may identify the carrier and reference the bill of lading number in lieu of the transporter's signature.</p> <p>One copy of the chain of custody form will be filed as a temporary record of sample transfer by the Field Sampler. The original form will accompany the sample set and will be returned to Pioneer as part of the contracted laboratory QA/QC requirements. The original form and the transporter's receipt will be filed as part of the project's permanent records.</p> <p>The Project Manager (or designee) will track the chain of custody to ensure timely receipt of samples by an analytical laboratory.</p> <p>Shipping information, including date shipped, laboratory shipped to, transporter's identity (i.e., Federal Express), and tracking number should be recorded in the field logbook. If more than one sample shipment occurs during a project, the associated samples per shipment should be referenced (sample numbers or samples collected on these dates).</p>
<p>Sample Handling.</p>	<p>All samples will be collected and handled in accordance with SOP-SA-01 Soil and Water Sample Packaging and Shipping and SOP-SA-02 Sample Preservation and Containerization for Aqueous Samples, or methods described in the Sampling and Analysis Plan (SAP) or Work Plan (WP). Samples will be transported in insulated coolers with ice as necessary to maintain a temperature of 4 degrees Celsius (°C) plus or minus 2 °C until receipt by the analytical laboratory. Alternate shipping containers can be used if the analytical method, SAP, or WP does not have temperature requirements for the samples.</p>



SOP-SA-04
CHAIN OF CUSTODY FORMS
FOR ENVIRONMENTAL
SAMPLES

AUTHORIZED
VERSION:
 11/12/2020
 PAGE 4 of 7

HEALTH SAFETY SECURITY ENVIRONMENT (HSSE) CONSIDERATIONS

This section to be completed with concurrence from the Safety and Health Manager.

<i>SOURCE</i>	<i>HAZARDS</i>	<i>WHERE</i>	<i>HOW, WHEN, RESULT</i>	<i>CONTROLS</i>
CHEMICAL	Potential contact with contaminated water/soil samples.	Outside of bottles.	Inadvertent exposure to contaminated water/soil samples could lead to adverse health effects.	Personnel will practice proper personal hygiene – wash hands prior to eating/drinking and when leaving the site. Personnel will wear nitrile gloves and safety glasses when handling sample containers.
	Preservatives (HCL, HNO ₃ , H ₂ SO ₄ , Zinc, Acetate, and NaOH).	Outside of bottles.	Inadvertent exposure to preservatives could lead to adverse health effects.	Safety Data Sheets for each preservative chemical are available to all Personnel on the Pioneer company web site. Personnel will wear nitrile gloves and safety glasses when handling the bottles. Refer to the Chemical Flushing Guidelines available inside vehicle's first aid kit for first-aid procedures in case of contact with preservatives.
NOISE	Not applicable.			
ELECTRICAL	Not applicable.			
BODY MECHANICS	Improper lifting.	Sites.	Back injuries and muscle/back strains could result when using improper techniques to lift and carry packaged samples and coolers.	Personnel will use proper lifting techniques – get a good grip, keep the load close to the body, lift with legs and not with back, and avoid lifting loads above shoulder's height. Two workers will lift/carry packaged samples and coolers, if needed.



SOP-SA-04
CHAIN OF CUSTODY FORMS
FOR ENVIRONMENTAL
SAMPLES

AUTHORIZED
VERSION:
 11/12/2020
 PAGE 5 of 7

HEALTH SAFETY SECURITY ENVIRONMENT (HSSE) CONSIDERATIONS

This section to be completed with concurrence from the Safety and Health Manager.

<i>SOURCE</i>	<i>HAZARDS</i>	<i>WHERE</i>	<i>HOW, WHEN, RESULT</i>	<i>CONTROLS</i>
GRAVITY	Falls from slips and trips.	Uneven terrain, slick/muddy/wet surfaces and steep slopes.	Walking/working on slick/muddy/wet and uneven terrain could cause slips and trips resulting in falls and injuries.	Personnel will wear work boots with good traction and ankle support. Personnel will be aware of working/walking surfaces and choose a path to avoid hazards. Keep work areas as dry as possible.
WEATHER	Not applicable.			
RADIATION	Not applicable.			
BIOLOGICAL	Not applicable.			
MECHANICAL	Not applicable.			
PRESSURE	Not applicable.			
THERMAL	Not applicable.			
HUMAN FACTORS	Inexperienced and improperly trained personnel.	Sites.	Inexperienced personnel and improper training could cause incidents resulting in adverse health effects and/or property damage.	Personnel will be properly trained in this procedure and other applicable procedures. Personnel will implement stop work procedures, if necessary.
SIMOPS (Simultaneous Operations)	Not applicable.			



SOP-SA-04
CHAIN OF CUSTODY FORMS
FOR ENVIRONMENTAL
SAMPLES

AUTHORIZED
VERSION:
 11/12/2020
 PAGE 6 of 7

ADDITIONAL HSSE CONSIDERATIONS
 This section to be completed with concurrence from the Safety and Health Manager.

REQUIRED PPE	Personal Protection Equipment (PPE): Safety glasses, high-visibility work shirt or vest, long pants, work boots, and nitrile gloves.
APPLICABLE SDSs	Safety Data Sheets (SDSs): HCL, HNO ₃ , H ₂ SO ₄ , Zinc, Acetate, and NaOH. Safety Data Sheets are available to Pioneer employees at the link below: https://pioneertechnicalservices.sharepoint.com/Safety/SafetyDataSheets
REQUIRED PERMITS/ FORMS	Per site/project requirements.
ADDITIONAL TRAINING	Per site/project requirements.

DRAWINGS, DOCUMENTS, AND TOOLS/EQUIPMENT
 The following documents should be referenced to assist in completing the associated task.

DRAWINGS	
RELATED SOPs/ PROCEDURES/ WORK PLANS	SOP-SA-01 Soil and Water Sample Packaging and Shipping and SOP-SA-02 Sample Preservation and Containerization for Aqueous Samples.
TOOLS/ EQUIPMENT	Seals and labels, chain of custody forms, chain of custody seals (provided by contracted laboratory), packing and shipping materials, cooler, and ice.
FORMS/ CHECKLIST	Chain of custody forms.





SOP-SA-04
CHAIN OF CUSTODY FORMS
FOR ENVIRONMENTAL
SAMPLES

AUTHORIZED
VERSION:
11/12/2020
PAGE 7 of 7

APPROVALS/CONCURRENCE

By signing this document, all parties acknowledge the completeness and applicability of this SOP for its intended purpose. Also, by signing this document, it serves as acknowledgement that I have received training on the procedure and associated competency testing.

SOP TECHNICAL AUTHOR	DATE
 Julie Flammang	11/12/2020
SAFETY AND HEALTH MANAGER	DATE
 Tara Schleeman	11/12/2020



PURPOSE	This SOP establishes the requirements for documenting and maintaining field logbooks and photographs. These procedures shall apply to all types of air, soil, water, sediment, biological, and/or core samples collected in environmental investigation by Pioneer Technical Services, Inc. (Pioneer). These procedures apply from the time field work begins until site activities are completed.
----------------	--

SCOPE	This practice has been prepared for the Pioneer workforce and applies to work carried out by and on behalf of Pioneer. All members of the Pioneer workforce who conduct the work shall be trained and competent in the risk-assessed work described below.
--------------	--

WORK INSTRUCTIONS

The following instructions are intended to provide sufficient guidance to perform the task in a safe, accurate, and reliable manner. Should these instructions present information that is inaccurate or unsafe, operations personnel must bring the issue to the attention of the Project Manager and the appropriate revisions made. All work carried under this SOP will be consistent with procedures and policies described in the appropriate Operation, Maintenance, and Monitoring (O&M) Plan (where applicable), appropriate Site-Specific Health and Safety Plan (SSHASP), and Pioneer Corporate Health and Safety Plan (HASP).

TASK	INSTRUCTIONS
1. Logbooks.	<p>A designated field logbook will be used for each field project. If requested by the Project Manager, use a separate field logbook for each field task within a larger project. Label each logbook with the project name, dates that it covers, and logbook number. Use a waterproof marker, such as a Sharpie[®], to write down the information. The logbooks will be bound and have consecutively numbered pages.</p> <p>The information recorded in these logbooks shall be written in ink. Begin a new page for each days notes. Write on every line of the logbook. If a blank space is necessary for clarity, such as a change of subject, skip one line before beginning the new subject. Do not skip any pages or parts of pages unless a day's activity ends in the middle of a page. Draw a diagonal line on any blank spaces of four lines or more to prevent unauthorized entries. The author will initial and date entries at the end of each day. All corrections will consist of a single line-out deletion in ink, followed by the author's initials and the date. Information not related to the project should not be entered in the logbook. The language used in the logbook should be factual and objective.</p> <p>These bound logbooks shall include the following entries:</p> <ol style="list-style-type: none"> 1. A description of the field task. 2. Time and date fieldwork started. 3. Location and/or a description of the work areas including sketches, if needed, any maps or references needed to identify locations, and sketches of construction activities. If the location has been documented in the logbook during/prior visits, only changes in conditions should be noted. 4. Names and company affiliations of field personnel.



	<ol style="list-style-type: none"> 5. Name, company affiliation or address, and phone number of any field contacts or official site visitors. 6. Meteorological conditions at the beginning of fieldwork and any ensuing changes in these conditions. 7. Details of the fieldwork performed and reference to field data sheets, if used. 8. Deviation from the task-specific Sampling and Analysis Plan (SAP), Work Plan (WP), or Standard Operating Procedures (SOP). 9. All field measurements made. 10. Any field laboratory analytical results. 11. Personnel and equipment decontamination procedures, if appropriate. <p>For any field sampling work, the following entries should be made:</p> <ol style="list-style-type: none"> 1. Sample location and number. 2. Sample type and amount collected. 3. Date and time of sample collection. 4. Type of sample preservation. 5. Split samples taken by other parties. Note the type of sample, sample location, time/date, name of person for whom the split was collected, that person's company, and any other pertinent information. 6. Sampling method, particularly any deviations from the SOP. 7. Documentation or reference of preparation procedures for reagents or supplies that will become an integral part of the sample, if available. This information may not be available for water or soil sampling bottles that come preserved from the laboratory or for preservatives provided by the laboratory. Bottle blanks will need to be used to evaluate the provided reagents. 8. The laboratory where the samples will be sent. <p>No bound field logbooks will be destroyed or thrown away even if they are illegible or contain inaccuracies that require a replacement document.</p>
<p>2. Photographs.</p>	<p>Take photographs of field activities using a digital camera. Photographs should include a scale in the picture when practical. Telephoto or wide-angle shots will not be used, since they cannot be used in enforcement meetings. The following items shall be recorded in the bound field logbook or on a field data sheet for each</p>



photograph taken:

1. The photographer's name, the date, the time of the photograph, and the general direction faced.
2. A brief description of the subject and the fieldwork portrayed in the picture.
3. Sequential number of the photograph.

An electronic copy and/or a hard copy of the photographs shall be placed in task files in the field office after each day of field activities. Supporting documentation from the bound field logbooks or field data sheets shall be photocopied and placed in the task files to accompany the photographs once the field activities are complete.



HSSE CONSIDERATIONS
 This section to be completed with concurrence from the Safety and Health Manager.

<i>SOURCE</i>	<i>HAZARDS</i>	<i>WHERE</i>	<i>HOW, WHEN, RESULT</i>	<i>CONTROLS</i>
CHEMICAL	Not applicable.			
NOISE	Not applicable.			
ELECTRICAL	Not applicable.			
BODY MECHANICS	Not applicable.			
GRAVITY	Not applicable.			
WEATHER	Not applicable.			
RADIATION	Not applicable.			
BIOLOGICAL	Not applicable.			
MECHANICAL	Not applicable.			
PRESSURE	Not applicable.			
THERMAL	Not applicable.			
HUMAN FACTORS	Not applicable.			
SIMOPS	Not applicable.			

ADDITIONAL HSSE CONSIDERATIONS
 This section to be completed with concurrence from the Safety and Health Manager.

REQUIRED PPE	
APPLICABLE SDS	Safety Data Sheets (SDSs) will be maintained based on site characterization and contaminants.
REQUIRED PERMITS/FORMS	Per site/project requirements.
ADDITIONAL TRAINING	Per site/project requirements.





DRAWINGS, DOCUMENTS, AND TOOLS/EQUIPMENT

The following documents should be referenced to assist in completing the associated task.

P&IDS	
DRAWINGS	
RELATED SOPs/PROCEDURES/WORK PLANS	
TOOLS	Field logbook, Sharpie©, black pen, digital camera, and field data sheets.
FORMS/CHECKLIST	

APPROVALS/CONCURRENCE

By signing this document, all parties acknowledge the completeness and applicability of this SOP for its intended purpose. Also, by signing this document, it serves as acknowledgement that I have received training on the procedure and associated competency testing.

SOP TECHNICAL AUTHOR	DATE
 Julie Flammang	12/17/2014
SAFETY AND HEALTH MANAGER	DATE
 Tara Schleeman	12/17/2014

Revisions:

Revision	Description	Date



**SOP-SFM-02;
OPERATING XL3 X-RAY
FLUORESCENCE ANALYZER**

DATE ISSUED:
06/05/2015
REVISION: 0
PAGE 1 of 8

PURPOSE	To provide standard instructions for operating XL3 X-Ray Fluorescence (XRF) analyzer.
SCOPE	This practice has been prepared for the Pioneer Technical Services, Inc. (Pioneer) workforce and applies to work carried out by and on behalf of Pioneer. All members of the Pioneer workforce who conduct the work shall be trained and competent in the risk-assessed work described below.

WORK INSTRUCTIONS

The following instructions are intended to provide sufficient guidance to perform the task in a safe, accurate, and reliable manner. Should these instructions present information that is inaccurate or unsafe, operations personnel must bring the issue to the attention of the Project Manager and the appropriate revisions made. All work carried under this SOP will be consistent with procedures and policies described in the appropriate Operation, Maintenance, and Monitoring (O&M) Plan (where applicable), appropriate Site-Specific Health and Safety Plan (SSHASP), and Pioneer Corporate Health and Safety Plan (HASP).

TASK	INSTRUCTIONS
1. Assemble XRF stand.	<ol style="list-style-type: none"> a. Open the case containing the stand and insert 4 legs into base of stand. b. Place stand on a solid, level surface.
2. Prep XRF sample for analysis.	<ol style="list-style-type: none"> a. Wearing latex or nitrile gloves, remove any large aggregate from the sample and place in a separate bag for disposal. For gravel or rocky soils, a sieve can be used to remove the large aggregates. If a sieve is used, it needs to be decontaminated between samples. Refer to SOP-DE-02 Equipment Decontamination for instructions. b. Consolidate the sample into the bottom of the baggie. c. Open the lid to the XRF stand and place sample inside, making sure that sample is flush against the opening on the inside of the XRF stand. d. Close the lid to the XRF stand.
3. Turn on XRF analyzer.	<ol style="list-style-type: none"> a. Open the XRF case and remove XRF gun from case. b. Slide XRF battery onto bottom of XRF gun handle. c. Press and hold power button (⏻) until XRF gun turns on and wait for system to start. d. Press where it says 'press to logon.' A warning message appears asking to verify that the user is aware of the radiation source in the XRF unit. e. Press 'Yes' to continue.
4. Log in and calibrate detector.	<ol style="list-style-type: none"> a. Type password (1234) when prompted. b. Click 'E' to log in. After logging in, a screen appears with 7 icons appears, this is the Main Menu screen. c. Tap the 'System Check' icon. d. Tap 'Yes.' e. The XRF unit will then go through an internal calibration. f. When the calibration is done, tap 'CLOSE' on the XRF gun to return to the Main Menu screen. <p style="text-align: center;">The detector should be calibrated at the start of each day of operation.</p>



**SOP-SFM-02;
OPERATING XL3 X-RAY
FLUORESCENCE ANALYZER**

DATE ISSUED:
06/05/2015
REVISION: 0
PAGE 2 of 8

<p>5. Set up XRF run test.</p>	<ol style="list-style-type: none"> a. Set parameters (e.g., analysis types, time, and analytes) required for the analysis as detailed in the XL3 user’s manual, Sampling and Analysis Plan (SAP), or Work Plan (WP). b. Once logged into XRF system, tap the ‘Analyze’ icon on XRF screen. A screen appears. c. On the next screen tap ‘Soils.’ d. On the next screen tap ‘Data Entry.’ A Data Entry screen appears showing several options (Sample Name, Sampler, Date, etc.). e. In the upper right hand corner, next to the ‘Sample Name’ icon, click the symbol that looks like a miniature keyboard to display a keyboard on the screen. f. Type in the sample name (do not press return yet). g. Insert XRF gun into the bottom of the XRF stand with the XRF gun handle pointing away from you. Be sure that the XRF gun is securely in place in the bottom of the stand. h. Press ‘return’ in the lower right corner of the keyboard screen. i. To activate the unit, pull the trigger on the gun handle. The analysis will take approximately 2 minutes to complete.
<p>6. Record data.</p>	<ol style="list-style-type: none"> a. After the XRF analysis is complete, results from the analysis will appear on the screen. b. Record the results and Test Number displayed on the screen; use the up and down arrows on the XRF gun to scroll through data. c. Open the lid on the XRF stand and remove the sample. d. Mark the sample baggie as “RAN” so that sample does not get analyzed twice. Place ran samples in a labeled box for storage and record keeping.
<p>7. Run additional samples.</p>	<ol style="list-style-type: none"> a. With the XRF gun still in the XRF stand, press the return button (↩) on the XRF gun. This will display the ‘Data Entry’ screen. b. On the Data Entry Screen, press the keyboard symbol located to the right of ‘Sample Name’ to display the keyboard. c. Type the next sample name (do not press return yet). d. Place the sample into the XRF stand and close the lid to the stand (as discussed in Task 2). e. Repeat the steps in Task 5 to activate the XRF unit. f. Repeat Tasks 6 and 7 until all samples are analyzed.
<p>8. Turn off XRF.</p>	<ol style="list-style-type: none"> a. After all samples have been analyzed, remove the XRF gun from the bottom of the stand (press and hold buttons on the side of the stand to allow XRF gun to be removed from stand). b. Press the return button (↩) on the XRF gun until the Main Menu screen appears. c. Press and hold the power button (⏻) until the XRF turns off. d. Remove the battery from the gun and place these items back into the appropriate case. e. Disassemble the XRF stand and place back into the appropriate case.



**SOP-SFM-02;
OPERATING XL3 X-RAY
FLUORESCENCE ANALYZER**

**DATE ISSUED:
06/05/2015
REVISION: 0
PAGE 3 of 8**

Quality
Assurance/Quality
Control (QA/QC)
Requirements.

Required QA/QC tasks:

1. Run the Niton-supplied XRF blanks and NIST standards at the start of each day.
2. Record the results in the field logbook or on the XRF field datasheet or equivalents. If the results are not within the ranges supplied by NITON in the user manual, initiate troubleshooting tasks on the analyzer (refer to the user's manual).
3. Run the blank and one standard QA/QC samples during sample analysis at the rate of 1 for every 20 samples analyzed. QA/QC includes analyzing a replicate sample every 20 samples and a duplicate sample (see the steps below).

Analyze a replicate sample (1 for every 20 samples analyzed)

1. After recording the initial reading for a sample, DO NOT remove the sample from the holder.
2. Restart the XRF gun and rerun the sample.
3. Record the information on the field data form or logbook as a replicate (or R sample). Replicates samples help track the precision of the XRF.

Analyze a duplicate sample (after every 20 samples analyzed)

1. After every 20 samples, analyze a duplicate sample by recording the results of the 20th sample.
2. Remove the sample bag from the XRF stand, remix the sample, and replace it in the XRF stand.
3. Reanalyze the sample.
4. Record the results as a duplicate (or D sample). Duplicates help to determine the precision of the XRF analysis as well as the homogeneity of the sample matrix.
5. Run a NITON-supplied blank or NIST standard after the replicate/duplicate QA/QC samples to monitor the accuracy of the XRF results.



**SOP-SFM-02;
OPERATING XL3 X-RAY
FLUORESCENCE ANALYZER**

DATE ISSUED:
06/05/2015
REVISION: 0
PAGE 4 of 8

HSSE CONSIDERATIONS

This section to be completed with concurrence from the Safety and Health Manager.

<i>SOURCE</i>	<i>HAZARDS</i>	<i>WHERE</i>	<i>HOW, WHEN, RESULT</i>	<i>CONTROLS</i>
CHEMICAL	Potential contact with contaminated soil.	Reclamation sites and within samples.	Inadvertent exposure to contaminated soil via ingestion could result in adverse health effects.	Personnel will practice proper personal hygiene – wash hands prior to eating/drinking and handling soil samples. Workers will wear nitrile gloves and safety glasses when handling samples to prevent exposure.
NOISE	Not applicable.			
ELECTRICAL	Not applicable.			
BODY MECHANICS	Improper lifting. Repetitive motion.	Sites. From removing rocks from sample bags or filling sample cups.	Back injuries and muscle/back strains could result when using improper lifting techniques to lift/carry XRF analyzer. Repetitive motion can result in hand cramps and fatigue.	Personnel will use proper lifting techniques: get a good grip, keep the load close to the body, lift with legs and not with back, and avoid lifting loads above shoulder's height. Take breaks if necessary. Personnel will ensure they are fit for duty, avoid staying in one position for long periods of time, and set up work area to minimize ergonomic risks. Personnel will take breaks, if necessary. Use appropriate tools (e.g., plastic spoon or tamper) to pack sample cups. Use a sieve to remove rocks from samples prior to bagging, if needed.
GRAVITY	Falls from slips and trips.	Uneven terrain, slick/muddy/wet surfaces and steep slopes.	Walking/working on slick/muddy/wet and uneven terrain could cause slips and trips resulting in falls and injuries.	Personnel will wear work boots with good traction and ankle support. Personnel will be aware of working/walking surfaces and choose a path to avoid hazards. If conditions are wet or muddy, wear muck boots.



**SOP-SFM-02;
OPERATING XL3 X-RAY
FLUORESCENCE ANALYZER**

DATE ISSUED:
06/05/2015
REVISION: 0
PAGE 5 of 8

HSSE CONSIDERATIONS

This section to be completed with concurrence from the Safety and Health Manager.

	Dropping the XRF analyzer.	Sites.	Personnel could be injured if the XRF analyzer is dropped on their feet.	Personnel will wear steel-toe boots. Personnel will ensure the XRF analyzer is set up on a solid surface and is not moved until sampling is complete.
WEATHER	Cold/heat stress.	Outdoor sites.	Exposure to cold climates may result in cold burns, frostbites, and hypothermia. Exposure to high temperatures may result in heat cramps, heat exhaustion, or heat stroke.	Training on signs and symptoms of cold/heat stress is required. Personnel will wear appropriate clothing when working outdoors. Personnel will remain hydrated and will have sufficient caloric intakes during the day. Personnel will follow procedures outlined in applicable SSHASP and/or Pioneer corporate HASP.
	Lightning.	Outdoor sites.	Electrocution, injury, death, or equipment damage could result from lightning strike.	Employees will follow the 30/30 rule during lightning storms.
RADIATION	Radiation from x-ray tube.	X-ray tube.	Exposure to radiation could lead to serious adverse health effects.	Radiation from the x-ray tube is fully contained within the device when not in use and allowed to escape through the measurement window only while the user is analyzing a sample. Radiation emission is controlled by a shutter. Personnel will keep hands and all body parts away from the front end of the analyzer when the shutter is open to minimize exposure. Personnel will not hold the analyzer near the measurement window during testing. Never point the analyzer at yourself or anyone else when the shutter is open. Never hold samples during analysis or look into the path of the primary beam.



**SOP-SFM-02;
OPERATING XL3 X-RAY
FLUORESCENCE ANALYZER**

DATE ISSUED:
06/05/2015
REVISION: 0
PAGE 6 of 8

HSSE CONSIDERATIONS

This section to be completed with concurrence from the Safety and Health Manager.

	Ultraviolet (UV) radiation.	Outdoor sites.	Employees could be exposed to UV radiation during summer months causing sun burns, skin damage, and eye damage.	Employees will wear safety glasses with tinted lenses, long-sleeve work shirts, and long pants. Employees should wear sunscreen, if necessary.
BIOLOGICAL	Plants, insects, and animals.	Outdoors.	Exposure to plants, insects, and/or animals may cause rashes, blisters, redness, and swelling.	Training on the signs and symptoms of exposure to plants, insects, and animals is required. Avoid contact with plants, insects, and animals. First-aid kits will be available on site. Employees with allergies will notify their supervisor.
MECHANICAL	Pinch points.	Transport case, XRF lid, and setting up work table.	Hand/finger injuries from pinching fingers in transport case/ XRF lid and when setting up the work table.	Personnel will wear work gloves to prevent injuries from pinch points.
PRESSURE	Not applicable.			
THERMAL	Not applicable.			
HUMAN FACTORS	Inexperienced and improperly trained worker.	Sites.	Inexperienced workers and improper training could cause incidents resulting in adverse health effects and/or property damage.	Employees will be properly trained in the procedure described above and other applicable procedures. Employees will follow the stop work policy, if there are any issues.
SIMOPS	Not applicable.			



**SOP-SFM-02;
OPERATING XL3 X-RAY
FLUORESCENCE ANALYZER**

DATE ISSUED:
06/05/2015
REVISION: 0
PAGE 7 of 8

HSSE CONSIDERATIONS

This section to be completed with concurrence from the Safety and Health Manager.

ADDITIONAL HSSE CONSIDERATIONS

This section to be completed with concurrence from the Safety and Health Manager.

REQUIRED PPE	Hard hat, safety glasses, high-visibility work shirt or vest, long pants, work boots, nitrile or latex gloves, and work gloves.
APPLICABLE SDS	Safety Data Sheets (SDSs) will be maintained based on site characterization and contaminants.
REQUIRED PERMITS/FORMS	Per site/project requirements.
ADDITIONAL TRAINING	Per site/project requirements.

DRAWINGS, DOCUMENTS, AND TOOLS/EQUIPMENT

The following documents should be referenced to assist in completing the associated task.

P&IDS	
DRAWINGS	
RELATED SOPs/PROCEDURES/ WORK PLANS	SOP-DE-02 Equipment Decontamination.
TOOLS	XRF and hand tools.
FORMS/CHECKLIST	





**SOP-SFM-02;
OPERATING XL3 X-RAY
FLUORESCENCE ANALYZER**

DATE ISSUED:
06/05/2015
REVISION: 0
PAGE 8 of 8

APPROVALS/CONCURRENCE

By signing this document, all parties acknowledge the completeness and applicability of this SOP for its intended purpose. Also, by signing this document, it serves as acknowledgement that I have received training on the procedure and associated competency testing.

SOP TECHNICAL AUTHOR	DATE
 Julie Flammang	06/05/2015
SAFETY AND HEALTH MANAGER	DATE
 Tara Schleeman	06/05/2015

Revisions:

Revision	Description	Date



**SOP-SURVEY-01;
STAKING AND SURVEYING**

DATE ISSUED:
10/24/2016
REVISION: 4
PAGE 1 of 11

PURPOSE	To provide standard instructions for operating survey equipment, staking, flagging and painting survey marks, and recording of field work performed.
SCOPE	This practice has been prepared for the Pioneer Technical Services, Inc. (Pioneer) workforce and applies to work carried out by and on behalf of Pioneer. All members of the Pioneer workforce who conduct the work will be trained and competent in the risk-assessed work described below.
<p>WORK INSTRUCTIONS</p> <p>The following instructions are intended to provide sufficient guidance to perform the task in a safe, accurate, and reliable manner. Should these instructions present information that is inaccurate or unsafe, operations personnel must bring the issue to the attention of the Project Manager and the appropriate revisions made. All work performed under this SOP will be consistent with procedures and policies described in the appropriate Operation, Maintenance, and Monitoring (O&M) Plan (where applicable), appropriate Site-Specific Health and Safety Plan (SSHASP), and Pioneer Corporate Health and Safety Plan (HASP).</p>	
TASK	INSTRUCTIONS
1. Storing survey equipment.	Store survey equipment in a secure, climate-controlled weatherproof area when not in use.
2. Charging Global Positioning System (GPS), robot, and data collector batteries.	<p>Charge batteries used in survey equipment in a climate-controlled weatherproof area. The use of a surge protector (power strip) to supply power to the battery chargers is recommended.</p> <p>Only use manufacturer’s approved batteries and chargers.</p>
3. Transporting survey equipment in vehicles.	<p>Transport survey equipment in a weatherproof area of a vehicle to prevent unnecessary exposure to elements that could adversely affect the calibration of various survey instruments and their accessories.</p> <p>Secure equipment in the vehicle during transportation so that it does not become a projectile in the case of an accident or other sudden maneuver.</p>
4. Setting stakes/lath and hubs.	Setting of survey stakes and hubs often requires the use of a 3-to 4-pound engineer or drilling hammer (hand held) (refer to Figure 1) or a 8- to 12-pound sledgehammer, and a gad (frost pin) (refer to Figure 2) manufactured and/or distributed by Red Top or Lo-Ink, designed to mushroom and not splinter when struck, to create a pilot hole in various soil surfaces in order to set the stake or hub.



Figure 1 – Drilling Hammer



Figure 2 – Gad (Frost Pin)

The gad (frost pin) will be from an authorized survey supply company. Any type of gad (frost pin) that is made of a material that can create shrapnel (i.e., jack hammer bits) or from an unauthorized survey supply company will not be used. When hammering stakes/hubs into surface, care will be taken to avoid splintering of stake/hub.

Set the hubs and stakes/lath in the following manner:

- After determining the position of the hub/stake/lath, determine the soil condition.
- If soil is loose or non-compacted, simply drive the hub/stake/lath into the ground until the hub/stake/lath is stable.

If soil is hard packed or compacted, use the following steps:

- Make a pilot hole using a gad.
- Grip the gad in your non-dominant hand halfway up the length of the gad and place the point of the gad at the desired position of the survey point.
- Using the drilling hammer in your dominant hand, strike the top of the gad a sufficient number of times to make a pilot hole of the desired depth.
- To remove the gad from the pilot hole, strike the sides of the gad with the drilling hammer in opposing horizontal directions to loosen the gad.
- Remove the gad from the pilot hole and insert the hub/stake/lath into the ground until the hub/stake/lath is stable.

5. Setting rebar.

Setting of rebar is necessary to establish control points and property corners. The use of a rebar driver (refer to Figure 3) manufactured and/or distributed by Surv-Kap or Lo-Ink, designed to mushroom and not splinter when struck, will be utilized to prevent mushrooming of the rebar and to allow for a larger striking surface. The proper sized driver for the proper sized rebar will be used (i.e., 1/2 inch for #4 rebar, 5/8 inch for #5 rebar, etc.).

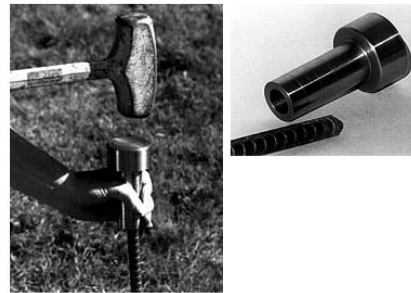

Figure 3 – Rebar Driver

Set rebar in the following manner:

- After determining the desired position of the property corner or control point, select a section of 5/8-inch rebar (12-inch length for control points, 24-inch length for property corners).
- Inspect the section of rebar and ensure that it is straight and free of burrs at the ends.
- Place one end of the rebar at the desired position and hold it with your non-dominant hand.
- Place the rebar driver over the end of the rebar. Using the drilling hammer (held in your dominant hand), strike the rebar driver until the bottom of the rebar driver contacts the surface that the rebar is being driven into. This will leave the rebar exposed approximately 2½ inches, allowing either a plastic or aluminum survey cap to be placed on the exposed end of the rebar.
- Drive the rebar and cap flush with the surface by placing a “cap driver” (sold by Surv-Kap) over the cap and striking the “cap driver” to set the cap flush to the surface.
- In the event that a control point or property corner needs to be set in a paved surface, a pilot hole will be drilled first with a hammer drill and the correct sized bit.

6. Checking points daily.

Check points will be performed daily (per job) to verify the following:

- Base point and height of base are correct.
- Survey coordinate system and datum are correct.
- Control remains within project specifications.

7. Using point ranges.

The following point ranges will be used on all jobs:

- 1-299 Project Control (found or set).
- 300-499 Found Monuments.
- 500-999 Calculated Monuments.
- 1000-2999 Calculated Design.
- 3000-Infinity Topo and staking store points.



**SOP-SURVEY-01;
STAKING AND SURVEYING**

**DATE ISSUED:
10/24/2016
REVISION: 4
PAGE 4 of 11**

<p>8. Booking of survey activities.</p>	<p>Record surveying activities on a daily basis (per job) in a field book to facilitate the ease of record keeping and the ability at a later date to recall the activity performed. The following will be the minimum data recorded in the field book:</p> <ul style="list-style-type: none">• Job name, location, coordinate system, and vertical datum used (header page) along with a brief description of the survey activities performed.• Date of field work and initials of all crew members.• Base point used along with height and type of measure up (fixed height, slant height, center bumper height, bottom of antenna mount, etc.).• Check point(s) used with Δ Northing, Δ Easting, and Δ Elevation differences written along with “Stored As” point (i.e., CK7-5 would be the 5th check point on CP7).• Any new control points or bench marks set (or found) along with their description.• Description of property corners set or found (e.g., type of rebar/cap, found stone, pipe, etc.) along with ties to any accessories (e.g., fence corners, bearing trees, road intersections, etc.).• Point ranges stored and a brief description (e.g., 3001-4063 – topo of road and ditches from xxx intersection to xxx intersection).• Type of alignments staked and the point range that staked points were stored in.• Occupy and backsight points for conventional survey work (gun work) along with backsight check and points staked – per set up.• Any changes in rod height and the associated point ranges.• Leveling bench marks, foresights, backsights, and side shots will be recorded (when leveling is performed).• Any pertinent sketches deemed necessary.• Any issues with equipment, land owners, contractors, etc. that arise.• Any other information deemed pertinent by the individual performing the survey. <p>Field books will be numbered in the following manner:</p> <ul style="list-style-type: none">• Volume by county using the Montana County numbers (i.e., Silver Bow is 1, Deer Lodge is 30, Lewis and Clark is 5, etc.).• Book by series (e.g., B1, B2, B3, etc.).• County name.• All of the above will be marked on the front outside cover and the side binding of the field book.• The title page at the beginning of the book will be filled out with the office information/address that the surveyor performing the work is based out of.<ul style="list-style-type: none">○ An example of field book number is: V1-B4 Silver Bow (i.e., Volume 1 – Book 4 of Silver Bow County).○ Each individual page will be numbered as such (i.e., V1-B4-1, V1-B4-2, etc.) in the upper right hand corner of each page. One page is considered to be both the left and right page of any given field book when in an open position.
---	---

	<ul style="list-style-type: none"> ○ Once a field book is filled, the index at the front of the book will be filled in to aid in future tracking of field work already performed. <p>The preferred type of field book is a Rite in the Rain All-Weather Transit No.300 series.</p> <p>Note: all of the above is necessary to provide for an accurate means of recalling activities performed.</p>
<p>9. Painting and flagging of survey marks.</p>	<div style="text-align: center;">  <p>Figure 4 – Spray Paint</p> </div> <p>Use the following steps when painting and flagging survey marks:</p> <ul style="list-style-type: none"> • Stand upwind of survey marks to be painted. • Invert spray can, aim nozzle at survey mark, and depress nozzle spraying paint in a sweeping motion. • After desired amount of paint has been dispensed, point nozzle straight up and depress nozzle on quick time to prevent clogging. • Flagging will be tied securely to the mark or stake as necessary. <p>Note: per the Mine Safety and Health Administration regulations, spray paint will not be stored in the cab of any vehicle. If it is necessary to warm cold paint cans up, do not leave cans unattended in the vehicle, and do not place them directly over heat vents.</p>
<p>10. Placing control points.</p>	<p>Locations of control points, especially those that may be used for a GPS base point or Total Station, will be placed in a safe location away from overhead and underground utilities and out of the lanes of traffic.</p> <p>The GPS control will be in an area that is obstruction free in order to have the best view of satellites in the sky. A minimum of three control points per project will be established, preferably intervisible. The preferred primary control type is a #5 rebar (12 inches long) with a 2 inch aluminum control cap marked with the Control Point Number and the year it was set stamped into it. Secondary control (i.e., any control that will not be used for longer than one month) can be a 60D nail and flagging, RR spike, hub and tack, or other acceptable “temporary” style of control.</p>



**SOP-SURVEY-01;
STAKING AND SURVEYING**

DATE ISSUED:
10/24/2016
REVISION: 4
PAGE 6 of 11

HSSE CONSIDERATIONS

This section to be completed with concurrence from the Safety and Health Manager.

<i>SOURCE</i>	<i>HAZARDS</i>	<i>WHERE</i>	<i>HOW, WHEN, RESULT</i>	<i>CONTROLS</i>
CHEMICAL	Potential contact with contaminated soils and dust.	Reclamation sites.	Adverse health effects could result from ingesting and/or inhaling contaminated soils/dust.	Personnel will practice proper personal hygiene: wash hands prior to eating/drinking and when leaving the site. Work will be suspended during high wind conditions that may produce large amounts of visible dust. Personnel will wear nitrile gloves, if contact with contaminated soil is possible.
	Fumes from marking paint.	Survey marks.	Inhalation of paint fumes when placing survey marks could result in adverse health effects such as headaches/dizziness.	Personnel will stay upwind from the paint being sprayed.
NOISE	Not applicable.			
ELECTRICAL	Equipment contact with overhead utilities.	Sites with overhead utilities.	Injury, death or property damage could occur from survey equipment (i.e., survey rod) contact with overhead utilities.	Personnel will follow the procedures outlined in the Pioneer Overhead Utilities Program. When possible, personnel will avoid areas with overhead utility hazards.
	Equipment contact with underground utilities.	Sites.	Injury, death or property damage could occur from survey equipment (i.e., gad, stake, and rebar) contact with underground utilities.	Personnel will follow the procedures outlined in the Pioneer Trenching, Excavation, and Ground Disturbance Program.



**SOP-SURVEY-01;
STAKING AND SURVEYING**

**DATE ISSUED:
10/24/2016
REVISION: 4
PAGE 7 of 11**

BODY MECHANICS	Repetitive motion.	Body.	Repetitive motion when reaching and positioning while using tools and survey equipment could result in injuries such as muscle strains.	Personnel will maintain a balanced position when reaching and positioning survey equipment. They will bend at knees while keeping back straight and upright to paint, place or pound in survey markers. Personnel should also stretch before starting work and will take breaks when necessary.
	Lifting and carrying tools and equipment.	Sites.	Improper lifting and carrying tools and equipment could result in back injuries and muscle/back strains.	Personnel will use proper lifting techniques: get a good grip, keep the load close to your body, lift with legs and not with back, and avoid lifting loads above shoulder height. Two people will lift heavy objects, if necessary.
GRAVITY	Uneven terrain, slick surfaces, and steep slopes.	Sites.	Walking/working on slick/muddy/wet and uneven terrain could cause slips and trips resulting in falls and injuries.	Personnel will wear work boots with good traction and ankle support, be aware of working/walking surfaces and choose a path to avoid hazards, keep work areas as dry as possible, and wear muck boots as necessary.
WEATHER	Cold/hot temperatures.	Outdoor sites.	Exposure to cold climates may result in cold burns, frostbite, and hypothermia. Exposure to high temperatures may result in heat cramps, heat exhaustion, or heat stroke.	Training on signs and symptoms of cold/heat stress is required. Personnel will wear appropriate clothing when working outdoors (e.g., layers and loose clothing), remain hydrated, and have sufficient caloric intakes during the day. Personnel will use their field vehicle to take breaks, when needed. Personnel will also follow the procedures outlined in the Pioneer Heat/Cold Stress Program.



**SOP-SURVEY-01;
STAKING AND SURVEYING**

DATE ISSUED:
10/24/2016
REVISION: 4
PAGE 8 of 11

WEATHER (cont.)	Lightning.	Outdoor sites.	Electrocution, injury, death or equipment damage could be caused by lightning strike.	Personnel will follow the 30/30 rule during lightning storms.
RADIATION	Ultraviolet (UV) radiation.	Outdoor sites.	Exposure to UV radiation during summer months can cause sun burns, skin damage, and eye damage.	Personnel will wear safety glasses with tinted lenses, long-sleeve work shirts, and long pants. Personnel should wear sunscreen, if necessary.
BIOLOGICAL	Plants, insects, and animals.	Outdoor sites.	Exposure to plants, insects, and animals may cause rashes, blisters, redness, swelling, and other injuries.	Training on the signs and symptoms of exposure to plants, insects, and animals is required. Personnel will avoid contact with plants, insects, and animals. First aid kits will be available on the site. Personnel with allergies will notify their supervisor.
MECHANICAL	Driving. Unsecured equipment.	Sites. Vehicle.	Interaction with light and heavy equipment could result in vehicle incidents. Driving on uneven/muddy/slick terrain could also result in vehicle incidents. Injury could result from being struck by an unsecured piece of equipment while driving.	Personnel will maintain communication with equipment operators and other site personnel, yield to haul traffic, and use defensive driving techniques. Personnel will not approach active heavy equipment with vehicle. If site conditions are not safe, postpone work or access the site using another means or route. Personnel will secure equipment to vehicle.



**SOP-SURVEY-01;
STAKING AND SURVEYING**

DATE ISSUED:
10/24/2016
REVISION: 4
PAGE 9 of 11

MECHANICAL (cont.)	Contact with engineer or drilling hammer.	Setting survey stakes and hubs.	Injuries to hands, foot, and knees could result when using an engineer or drilling hammer to set survey stakes and hubs.	Personnel will wear work gloves and steel-toed boots. Personnel will also keep knees away from the survey gad while creating a pilot hole. Be aware of finger/hand placement and do not put fingers/hands between objects. Inspect tools prior to each use.
	Flying debris.	Setting survey stakes, hubs, and rebar.	Survey gad, stakes, hubs, and rebar could splinter and/or break while being struck with hammer and flying pieces could cause eye injuries.	Personnel will wear safety glasses. Personnel will use survey gad designed to mushroom and not splinter when struck. When establishing control points/property corners, personnel will use a rebar driver to set up rebar. Personnel will also inspect survey gad, stakes, hubs, and rebar prior to installing them.
	Pinch points.	Hand tools and equipment.	Exposure to pinch points when using hand tools and equipment could result in personal injuries.	Personnel will wear work gloves to protect against pinch-point injuries. Inspect all tool and equipment prior to each use.
PRESSURE	Not applicable.			
THERMAL	Not applicable.			
HUMAN FACTORS	Inexperienced and improperly trained personnel.	Sites.	Inexperienced personnel and improper training could cause incidents resulting in injuries and/or property damage.	Personnel will be trained in this procedure and other applicable procedures. Personnel will implement stop work procedures, if necessary.
SIMOPS	Not applicable.			



**SOP-SURVEY-01;
STAKING AND SURVEYING**

DATE ISSUED:
10/24/2016
REVISION: 4
PAGE 10 of 11

ADDITIONAL HSSE CONSIDERATIONS

This section to be completed with concurrence from the Safety and Health Manager.

REQUIRED PPE	Long-sleeved work shirt, high-visibility vest/outwear, long pants, safety glasses, hard hat, work globes, and steel-toed boots.
APPLICABLE SDS	Survey Marking Paint. Additional Safety Data Sheets (SDSs) will be maintained based on site characterization and contaminants.
REQUIRED PERMITS/FORMS	Per site/project requirements.
ADDITIONAL TRAINING	Per site/project requirements.

DRAWINGS, DOCUMENTS, AND TOOLS/EQUIPMENT

The following documents should be referenced to assist in completing the associated task.

P&IDS	
DRAWINGS	
RELATED SOPs/PROCEDURES/WORK PLANS	
TOOLS	Hand-held GPS, survey rod, engineer or drilling hammer, sledgehammer, survey gad, stakes, lath, rebar, rebar driver, survey cap, cap driver, paint cans, and field book.
FORMS/CHECKLIST	

APPROVALS/CONCURRENCE

By signing this document, all parties acknowledge the completeness and applicability of this SOP for its intended purpose. Also, by signing this document, it serves as acknowledgement that I have received training on the procedure and associated competency testing.

SOP TECHNICAL AUTHOR	DATE
Mike Newhouse	08/16/2016
SAFETY AND HEALTH MANAGER	DATE
Tara Schleeman	10/24/2016



**SOP-SURVEY-01;
STAKING AND SURVEYING**

DATE ISSUED:
10/24/2016
REVISION: 4
PAGE 11 of 11

APPROVALS/CONCURRENCE

By signing this document, all parties acknowledge the completeness and applicability of this SOP for its intended purpose. Also, by signing this document, it serves as acknowledgement that I have received training on the procedure and associated competency testing.

Revisions:

Revision	Description	Date



**SOP-SW-01;
SURFACE WATER/STREAM
SAMPLING**

DATE ISSUED:
12/17/2014
REVISION: 0
PAGE 1 of 6

PURPOSE	To provide standard instructions for the collection of aqueous samples from stream channels and drainage ditches.
SCOPE	This practice has been prepared for the Pioneer Technical Services, Inc. (Pioneer) workforce and applies to work carried out by and on behalf of Pioneer. All members of the Pioneer workforce who conduct the work shall be trained and competent in the risk-assessed work described below.

WORK INSTRUCTIONS

The following instructions are intended to provide sufficient guidance to perform the task in a safe, accurate, and reliable manner. Should these instructions present information that is inaccurate or unsafe, operations personnel must bring the issue to the attention of the Project Manager and the appropriate revisions made. All work carried under this SOP will be consistent with procedures and policies described in the appropriate Operation, Maintenance, and Monitoring (O&M) Plan (where applicable), appropriate Site-Specific Health and Safety Plan (SSHASP), and Pioneer Corporate Health and Safety Plan (HASP).

TASK	INSTRUCTIONS
Note	The samples collected will be composite or grab samples depending upon the sample site. Always collect samples from downstream to upstream locations and stand downstream of the sample bottles to avoid stream bed solids. If it is determined that the sampling water is highly polluted, an alternative method using a dipper or pump will be chosen. Wear gloves for all surface water sampling.
1. Label sample bottles and record sampling information.	Label the sample bottles with the appropriate sample number. Carefully and clearly address all the required categories and parameters. Place clear tape over the label. Record sampling information in the logbook or field data sheets and on the chain-of-custody form.
2. Rinse sampling equipment.	If the sample bottle was not received from the laboratory with the appropriate preservative, rinse the clean sample bottle (for unfiltered samples and inorganic analyses) three times with the water to be sampled. If collecting a composite sample from multiple stream segments, also rinse a decontaminated sampling bucket three times. If a water thief is to be used to collect water, it must also be rinsed three times.
3. Collect the sample.	Collect a grab or composite sample as specified in the Sampling and Analysis Plan (SAP) or Work Plan (WP). In general, if the channel width is less than 5 feet across, collect grab samples from the center of the channel. If the channel width is greater than 5 feet, divide the channel into 5-foot sections and collect a composite sample at the center of each section to obtain a channel-integrated sample. If needed, a clean water thief may be used to collect the water and the water then transferred to the sampling containers or mixing bucket. In some cases, because of



**SOP-SW-01;
SURFACE WATER/STREAM
SAMPLING**

**DATE ISSUED:
12/17/2014
REVISION: 0
PAGE 2 of 6**

	<p>safety considerations (e.g., fast water, deep water, entrapment hazards, freezing water, etc.), the grab sample will be collected from the stream bank.</p> <p>Submerge the sampling containers in the water, mouth pointing upstream and below the water surface. If it is necessary to stand in the stream, always collect sample upstream from the sampler's location, facing upstream. Samples shall be collected from the approximate midpoint between the stream bed and the stream surface. Take care not to collect any stream bed solids.</p> <p>If the sample bottle was received from the laboratory with preservatives, be careful not to overfill the bottle and lose the preservative.</p> <p>A peristaltic pump may also be used to collect a sample. Hold the new disposable tubing under the water surface and turn the pump ON.</p>
4. Add required preservatives.	<p>If collecting a grab sample, fill the sample bottle and add required preservatives (if needed) according to SOP-SA-02 Sample Preservation and Containerization for Aqueous Samples. Secure the bottle cap tightly.</p> <p>If collecting a composite sample, pour the filled container into the bucket and then take the additional grabs in each of the remaining channel sections. Collect an adequate volume of water to fill all of the required bottles. Stir or swirl the contents of the bucket gently and fill each of the sample bottles for that particular sample set. If needed, add required preservatives according to SOP-SA-02 Sample Preservation and Containerization for Aqueous Samples.</p>
5. Transport sample bottles.	<p>Place the properly labeled sample bottles in an appropriate carrying container maintained at 4°C +/- 2°C throughout the sampling and transportation period.</p>



**SOP-SW-01;
SURFACE WATER/STREAM
SAMPLING**

DATE ISSUED:
12/17/2014
REVISION: 0
PAGE 3 of 6

HSSE CONSIDERATIONS

This section to be completed with concurrence from the Safety and Health Manager.

<i>SOURCE</i>	<i>HAZARDS</i>	<i>WHERE</i>	<i>HOW, WHEN, RESULT</i>	<i>CONTROLS</i>
CHEMICAL	<p>Potential contact with contaminated water.</p> <p>Preservatives (HCL, HNO₃, H₂SO₄, Zinc, Acetate, and NaOH).</p>	<p>Streams, channels, and drainage ditches.</p> <p>In bottles or added to bottles through sampling process.</p>	<p>Inadvertent exposure to contaminated water could lead to adverse health effects.</p> <p>Inadvertent exposure to preservatives could lead to adverse health effects.</p>	<p>Personnel will practice proper personal hygiene – wash hands prior to eating/drinking and when leaving the site. Employees will wear nitrile gloves and safety glasses when collecting and handling samples.</p> <p>Safety Data Sheets for each preservative chemical are available to all employees on the Pioneer company web site. Personnel will wear nitrile gloves and safety glasses when adding preservatives to samples bottles and when handling the bottles. Refer to the Chemical Flushing Guidelines available inside vehicle’s first aid kit for first-aid procedures in case of contact with preservatives.</p>
NOISE	Not applicable.			
ELECTRICAL	Not applicable.			
BODY MECHANICS	<p>Improper lifting.</p> <p>Bending, squatting, and kneeling.</p>	<p>Testing sites.</p> <p>During sample collection.</p>	<p>Back injuries and muscle/back strains could result when using improper techniques to lift and carry tools and equipment.</p> <p>Bending, squatting, and kneeling during sample collection could result in muscle/back</p>	<p>Personnel will use proper lifting techniques – get a good grip, keep the load close to the body, lift with legs and not with back, and avoid lifting loads above shoulder’s height. Two employees will lift/carry objects, if necessary.</p> <p>Employees should stretch prior to starting work and they will take breaks when necessary.</p>



**SOP-SW-01;
SURFACE WATER/STREAM
SAMPLING**

DATE ISSUED:
12/17/2014
REVISION: 0
PAGE 4 of 6

	Drowning and/or entrapment hazards.	When entering bodies of water to collect samples.	strains or other injuries. Soft soils and/or sudden changes in depth of water could create drowning and/or entrapment hazards.	Workers will use rods to test soil stability and/or depth of water as they walk to sample locations. In addition, personnel may be required to wear life vests when crossing deeper bodies of water.
GRAVITY	Falls from slips and trips.	Uneven terrain, slick/muddy/wet surfaces and steep slopes.	Walking/working on slick/muddy/wet and uneven terrain could cause slips and trips resulting in falls and injuries.	Workers will wear work boots with good traction and ankle support. Personnel will be aware of working/walking surfaces and choose a path to avoid hazards. Keep work areas as dry as possible. Wear muck boots, as necessary.
WEATHER	Cold/heat stress.	Sites.	Exposure to cold climates may result in cold burns, frostbites, and hypothermia. Exposure to high temperatures may result in heat cramps, heat exhaustion, or heat stroke.	Training on signs and symptoms of cold/heat stress is required. Personnel will wear appropriate clothing when working outdoors. Employees will remain hydrated and will have sufficient caloric intakes during the day. Personnel will follow procedures outlined in applicable SSHASP and/or Pioneer corporate HASP.
	Hypothermia/frostbite.	Sites when air temperature is 35.6°F (2°C) or less.	Workers who become immersed in water or whose clothing becomes wet may be exposed to hypothermia and/or frostbite.	Employees will change clothing if it becomes wet. When applicable, employees will wear waders to prevent clothing from getting wet.
	Lightning.	Outdoor sites.	Electrocution, injury, death, or equipment damage could be caused by lightning strike.	Employees will follow the 30/30 rule during lightning storms.



**SOP-SW-01;
SURFACE WATER/STREAM
SAMPLING**

DATE ISSUED:
12/17/2014
REVISION: 0
PAGE 5 of 6

RADIATION	Ultraviolet (UV) radiation.	Outdoors.	Employees could be exposed to UV radiation during summer months causing sun burns, skin damage, and eye damage.	Employees will wear safety glasses with tinted lenses, long-sleeve work shirts, and long pants. Employees should wear sunscreen, if necessary.
BIOLOGICAL	Plants, insects, and animals.	Sites.	Exposure to plants, insects, and/or animals may cause rashes, blisters, redness, and swelling.	Training on the signs and symptoms of exposure to plants, insects, and animals is required. Avoid contact with plants, insects, and animals. First-aid kits will be available on site. Employees with allergies will notify their supervisor.
MECHANICAL	Not applicable.			
PRESSURE	Not applicable.			
THERMAL	Not applicable.			
HUMAN FACTORS	Inexperienced and improperly trained worker.	Sites.	Inexperienced workers and improper training could cause incidents resulting in adverse health effects and/or property damage.	Employees will be properly trained in this procedure and other applicable procedures. Employees will implement stop work procedures, if necessary.
SIMOPS	Not applicable.			

ADDITIONAL HSSE CONSIDERATIONS

This section to be completed with concurrence from the Safety and Health Manager.

REQUIRED PPE	Hard hat, safety glasses, high-visibility work shirt or vest, long pants, work boots, nitrile gloves, and leather gloves. Life jacket and rescue rope, if needed.
APPLICABLE SDS	HCL, HNO ₃ , H ₂ SO ₄ , Zinc, Acetate, and NaOH. Additional Safety Data Sheets (SDSs) will be maintained based on site characterization and contaminants.
REQUIRED PERMITS/FORMS	Per site/project requirements.





**SOP-SW-01;
SURFACE WATER/STREAM
SAMPLING**

DATE ISSUED:
12/17/2014
REVISION: 0
PAGE 6 of 6

ADDITIONAL TRAINING	Per site/project requirements.
----------------------------	--------------------------------

DRAWINGS, DOCUMENTS, AND TOOLS/EQUIPMENT	
The following documents should be referenced to assist in completing the associated task.	
P&IDS	
DRAWINGS	Map with site location and sample locations.
RELATED SOPs/PROCEDURES/WORK PLANS	SOP-SA-02 Sample Preservation and Containerization for Aqueous Samples.
TOOLS	<p>Sample bottles, cooler, and ice.</p> <p>Sampling bucket to collect samples from multiple stream segments.</p> <p>If needed: peristaltic pump and water thief.</p> <p>Field logbook or field data sheets and chain-of-custody forms.</p>
FORMS/CHECKLIST	

APPROVALS/CONCURRENCE	
By signing this document, all parties acknowledge the completeness and applicability of this SOP for its intended purpose. Also, by signing this document, it serves as acknowledgement that I have received training on the procedure and associated competency testing.	
SOP TECHNICAL AUTHOR	DATE
 Julie Flammang	12/17/2014
SAFETY AND HEALTH MANAGER	DATE
 Tara Schleeman	12/17/2014

Revisions:

Revision	Description	Date



PURPOSE	To provide standard instructions for conducting field filtration of water.
SCOPE	This practice has been prepared for the Pioneer Technical Services, Inc. (Pioneer) workforce and applies to work carried out by and on behalf of Pioneer. All members of the Pioneer workforce who conduct the work shall be trained and competent in the risk-assessed work described below.
WORK INSTRUCTIONS	
The following instructions are intended to provide sufficient guidance to perform the task in a safe, accurate, and reliable manner. Should these instructions present information that is inaccurate or unsafe, operations personnel must bring the issue to the attention of the Project Manager and the appropriate revisions made. All work carried under this SOP will be consistent with procedures and policies described in the appropriate Operation, Maintenance, and Monitoring (O&M) Plan (where applicable), appropriate Site-Specific Health and Safety Plan (SSHASP), and Pioneer Corporate Health and Safety Plan (HASP).	
TASK	INSTRUCTIONS
Field Sample Filtration	
Notes	<p>The general procedures listed below are applicable for field filtration of water samples for subsequent analysis of dissolved analytes.</p> <p>Refer to the following SOPs for the sampling setup in which filtering will occur:</p> <p>SOP-GW-02 Sampling with a Bailer SOP-GW-10 Purging and Sampling with a 12-Volt Submersible Pump SOP-GW-10A Purging and Sampling with a Low Flow Submersible Pump SOP-GW-10B Purging and Sampling with Grunfoss Redi-Flo Submersible Pump SOP-GW-10C Purging and Sampling with a Peristaltic Pump SOP-GW-13 Sampling Groundwater from a Tap</p>
Field Filtering When Sampling With A Bailer	
Notes	<p>Prior to the sample event include an extra 1-liter sample container for each sample site on the laboratory bottle order.</p> <p>If necessary, a 1-liter sample container can be decontaminated as described in SOP-DE-02 Equipment Decontamination. This is not recommended as there is a potential for introducing contamination.</p> <p>A new disposable filter is to be used for each sampling site.</p> <p>A peristaltic pump will be used for filtering the sample. Order peristaltic pump tubing: approximately 18 inches of silicon tubing and 12 inches of polyethylene tubing per sampling site.</p>
1. Setup.	Follow the procedures as outlined in SOP-GW-02 Sampling with a Bailer through the step for collecting samples.



2. Sample for filtering.	<p>While filling sample containers, also fill the extra 1- liter unpreserved sample container, this water will be used for filtering.</p> <p>Install new tubing in the peristaltic pump. Insert an in-line high capacity (0.45 µm) disposable filter on the tubing. Make sure that the filter is inserted so that the flow arrow is pointed toward the discharge end of the tubing. Start the pump and let a small amount of water flow through the filter before filling the sample container. Hold the filter at an angle to ensure no unfiltered water from the tubing leaks into the sample container and only the filtered water enters the sample container. If water stops discharging from filter, replace filter with a new filter.</p> <p>If one of the sample containers (unpreserved) for the actual sample was used in lieu of an extra container to collect the water for filtering, refill the container after filtration is completed. Follow the SOP-SA-02 Sample Preservation and Containerization for Aqueous Samples to complete sample collection.</p> <p>If extremely turbid water is encountered place an in-line high capacity (10 µm) disposable filter before the in-line high capacity (0.45 µm) disposable filter.</p>
3. Label, store, and ship samples.	Label the sample bottle as appropriate and place in a cooler. Ship with other samples in accordance with SOP-SA-01 Soil and Water Sample Packaging and Shipping.
4. Dispose of used bailer, tubing, filters and extra 1-liter sample container.	Bailer, tubing, filters and the extra 1-liter sample container used in the well sampling will be disposed of in accordance with SOP-DE-03 Investigation Derived Waste Handling.
Filtering Sample with 12-Volt Submersible Pump, Low Flow Submersible Pump and Grunfos Redi-Flo II Submersible Pump	
Note	A new disposable filter is to be used for each sampling site.
1. Setup.	Follow the procedures as outlined in the appropriate SOP listed above through the step for collecting samples.
2. Sample for filtering.	<p>After filling the unfiltered sample containers as detailed in SOP-SA-02 Sample Preservation and Containerization for Aqueous Samples insert an in-line high capacity (0.45 µm) disposable filter in the discharge end of the tubing. Make sure that the filter is inserted so that the flow arrow is pointed toward the discharge end of the tubing. Let a small amount of water flow through the filter before filling the sample container. Hold the filter at an angle to ensure no unfiltered water from the tubing leaks into the sample container and only the filtered water enters the sample container. If water stops discharging from filter replace filter with a new filter.</p> <p>If one of the sample containers (unpreserved) for the actual sample was used in lieu of an extra container to collect the water for filtering, refill the container after filtration is completed. Follow the SOP-SA-02 Sample Preservation and</p>



	<p>Containerization for Aqueous Samples to complete sample collection.</p> <p>If extremely turbid water is encountered place an in-line high capacity (10 µm) disposable filter before the in-line high capacity (0.45 µm) disposable filter.</p>
3. Label, store, and ship samples.	Label the sample bottle as appropriate and place in a cooler. Ship with other samples in accordance with SOP-SA-01 Soil and Water Sample Packaging and Shipping.
4. Dispose of used disposable tubing and filters.	Dispose of tubing and filters used in the well sampling in accordance with SOP-DE-03 Investigation Derived Waste Handling.
Filtering Sample with Peristaltic Pump	
Note	A new disposable filter is to be used for each sampling site.
1. Setup.	Follow the procedure for pump setup and purging as outlined in the SOP-GW-10C Purging and Sampling with a Peristaltic Pump through the step to collect samples.
2. Sample for filtering.	<p>After filling the unfiltered sample containers as detailed in SOP-SA-02 Sample Preservation and Containerization for Aqueous Samples place an in-line high capacity (0.45 µm) disposable filter on the discharge end of the tubing. Make sure that the filter is inserted so that the flow arrow is pointed toward the discharge end of the tubing. Let a small amount of water flow through the filter before filling the sample container. Hold the filter at an angle to ensure no unfiltered water from the tubing leaks into the sample container and only the filtered water enters the sample container. If water stops discharging from filter replace filter with a new filter.</p> <p>Follow the SOP-SA-02 Sample Preservation and Containerization for Aqueous Samples to complete sample collection.</p> <p>If extremely turbid water is encountered place an in-line high capacity (10 µm) disposable filter before the in-line high capacity (0.45 µm) disposable filter.</p>
3. Label, store, and ship samples.	Label the sample bottle as appropriate and place in a cooler. Ship with other samples in accordance with SOP-SA-01 Soil and Water Sample Packaging and Shipping.
4. Dispose of used disposable tubing and filters.	Dispose of tubing and filters used in the well sampling in accordance with SOP-DE-03 Investigation Derived Waste Handling.



Filtering Sample from a Tap

<p>Notes</p>	<p>Prior to the sample event include an extra 1 liter sample container per sample site on the laboratory bottle order.</p> <p>If necessary a 1-liter sample container can be decontaminated as described in SOP-DE-02 Equipment Decontamination. This is not recommended as there is a potential for introducing contamination.</p> <p>A new disposable filter is to be used for each sampling site.</p> <p>A peristaltic pump will be used for filtering the sample. Order peristaltic pump tubing: approximately 18 inches of silicon tubing and 12 inches of polyethylene tubing per sampling site.</p>
<p>1. Setup.</p>	<p>Follow the procedure for setup and purging as outlined in the SOP-GW-13 Sampling Groundwater From a Tap through the step for collecting samples.</p>
<p>2. Sample for filtering.</p>	<p>While filling sample containers, also fill the extra 1-liter unpreserved sample container, this water will be used for filtering.</p> <p>Install new tubing in the peristaltic pump. Insert an in-line high capacity (0.45 μm) disposable filter on the tubing. Make sure that the filter is inserted so that the flow arrow is pointed toward the discharge end of the tubing. Start the pump and let a small amount of water flow through the filter before filling the sample container. Hold the filter at an angle to ensure no unfiltered water from the tubing leaks into the sample container and only the filtered water enters the sample container. If water stops discharging from filter replace filter with a new filter.</p> <p>If one of the sample containers (unpreserved) for the actual sample was used in lieu of an extra container to collect the water for filtering, refill the container after filtration is completed. Follow the SOP-SA-02 Sample Preservation and Containerization for Aqueous Samples to complete sample collection.</p> <p>If extremely turbid water is encountered place an in-line high capacity (10 μm) disposable filter before the in-line high capacity (0.45 μm) disposable filter.</p>
<p>3. Label, store, and ship samples.</p>	<p>Label the sample bottle as appropriate and place in a cooler. Ship with other samples in accordance with SOP-SA-01 Soil and Water Sample Packaging and Shipping.</p>
<p>4. Disposable tubing, filters and if used extra 1 liter sample container.</p>	<p>Disposable tubing, filters and the extra 1 liter sample container will be disposed of in accordance with SOP-DE-03 Investigation Derived Waste Handling.</p>



HSSE CONSIDERATIONS

This section to be completed with concurrence from the Safety and Health Manager.

<i>SOURCE</i>	<i>HAZARDS</i>	<i>WHERE</i>	<i>HOW, WHEN, RESULT</i>	<i>CONTROLS</i>
CHEMICAL	<p>Potential contact with contaminated water and filters.</p> <p>Preservatives (HCL, HNO₃, H₂SO₄, Zinc, Acetate, and NaOH).</p>	<p>Testing sites.</p> <p>In bottles or added to bottles through sampling process.</p>	<p>Inadvertent exposure to contaminated water and filters could lead to adverse health effects.</p> <p>Inadvertent exposure to preservatives could lead to adverse health effects.</p>	<p>Personnel will practice proper personal hygiene – wash hands prior to eating/drinking and when leaving the site. Personnel will wear nitrile gloves and safety glasses.</p> <p>Safety Data Sheets for each preservative chemical are available to all employees on the Pioneer company website. Personnel will wear nitrile gloves and safety glasses when adding preservatives to sample bottles and when handling the bottles. Refer to the Chemical Flushing Guidelines available inside vehicle’s first aid kit for first-aid procedures in case of contact with preservatives.</p>
NOISE	Not applicable.			
ELECTRICAL	Not applicable.			
BODY MECHANICS	<p>Improper lifting.</p> <p>Bending, squatting, and kneeling.</p>	<p>Testing sites.</p> <p>During sample collection.</p>	<p>Back injuries and muscle/back strains could result when using improper techniques to lift and carry tools and equipment.</p> <p>Bending, squatting, and kneeling during sample collection could result in muscle/back strains or other injuries.</p>	<p>Personnel will use proper lifting techniques – get a good grip, keep the load close to the body, lift with legs and not with back, and avoid lifting loads above shoulder’s height. Two employees will lift objects, if necessary.</p> <p>Employees should stretch prior to starting work and they will take breaks when necessary.</p>



**SOP-SW-02;
FIELD SAMPLE FILTRATION**

DATE ISSUED:
05/28/2015
REVISION: 0
PAGE 6 of 8

GRAVITY	Falls from slips and trips.	Uneven terrain, slick/muddy/wet surfaces and steep slopes.	Walking/working on slick/muddy/wet and uneven terrain could cause slips and trips resulting in falls and injuries.	Workers will wear work boots with good traction and ankle support. Workers will be aware of working/walking surfaces and choose a path to avoid hazards. Keep work areas as dry as possible. Wear muck boots, as necessary.
WEATHER	Cold/heat stress. Lightning.	Sites. Outdoor sites.	Exposure to cold climates may result in cold burns, frostbites, and hypothermia. Exposure to high temperatures may result in heat cramps, heat exhaustion, or heat stroke. Electrocution, injury, death, or equipment damage could be caused by lightning strike.	Training on signs and symptoms of cold/heat stress is required. Personnel will wear appropriate clothing when working outdoors. Employees will remain hydrated and will have sufficient caloric intakes during the day. Employees will follow procedures outlined in applicable SSHASP and/or Pioneer corporate HASP. Employees will follow the 30/30 rule during lightning storms.
RADIATION	Ultraviolet (UV) radiation.	Outdoors.	Employees could be exposed to UV radiation during summer months causing sun burns, skin damage, and eye damage.	Employees will wear safety glasses with tinted lenses, long-sleeve work shirts, and long pants. Employees should wear sunscreen, if necessary.
BIOLOGICAL	Plants, insects, and animals.	Sites	Exposure to plants, insects, and/or animals may cause rashes, blisters, redness, and swelling.	Training on the signs and symptoms of exposure to plants, insects, and animals is required. Avoid contact with plants, insects, and animals. First-aid kits will be available on site. Employees with allergies will notify their supervisor.
MECHANICAL	Not applicable.			



PRESSURE	Not applicable.			
THERMAL	Not applicable.			
HUMAN FACTORS	Inexperienced and improperly trained worker.	Sites.	Inexperienced workers and improper training could cause incidents resulting in adverse health effects and/or property damage.	Employees will be properly trained in this procedure and other applicable procedures. Employees will implement stop work procedures, if necessary.
SIMOPS	Not applicable.			

ADDITIONAL HSSE CONSIDERATIONS

This section to be completed with concurrence from the Safety and Health Manager.

REQUIRED PPE	Hard hat, safety glasses, high-visibility work shirt or vest, long pants, work boots, nitrile gloves, and work gloves.
APPLICABLE SDS	HCL, HNO3, H2SO4, Zinc, Acetate, and NaOH. Additional Safety Data Sheets (SDSs) will be maintained based on site characterization and contaminants.
REQUIRED PERMITS/FORMS	Per site/project requirements.
ADDITIONAL TRAINING	Per site/project requirements.

DRAWINGS, DOCUMENTS, AND TOOLS/EQUIPMENT

The following documents should be referenced to assist in completing the associated task.

P&IDS	
DRAWINGS	Map with site location and sample locations.
RELATED SOPs/PROCEDURES/WORK PLANS	SOP-GW-02 Sampling with A Bailer SOP-GW-10 Purging and Sampling with a 12-Volt Submersible Pump SOP-GW-10A Purging and Sampling with a Low Flow Submersible Pump SOP-GW-10B Purging and Sampling with Grunfoss Redi-Flo Submersible Pump SOP-GW-10C Purging and Sampling with a Peristaltic Pump SOP-GW-13 Sampling Groundwater From a Tap SOP-DE-02 Equipment Decontamination SOP-SA-02 Sample Preservation and Containerization for Aqueous Samples SOP-SA-01 Soil and Water Sample Packaging and Shipping SOP-DE-03 Investigation Derived Waste Handling
TOOLS	Bailer, filter, tubing, pump, sample collection tools, cooler, sample bottles, and preservatives.





**SOP-SW-02;
FIELD SAMPLE FILTRATION**

**DATE ISSUED:
05/28/2015
REVISION: 0
PAGE 8 of 8**

FORMS/CHECKLIST

APPROVALS/CONCURRENCE

By signing this document, all parties acknowledge the completeness and applicability of this SOP for its intended purpose. Also, by signing this document, it serves as acknowledgement that I have received training on the procedure and associated competency testing.

SOP TECHNICAL AUTHOR	DATE
 Julie Flammang	05/28/2015
SAFETY AND HEALTH MANAGER	DATE
 Tara Schleeman	05/28/2015

Revisions:

Revision	Description	Date



**SOP-WFM-01
FIELD MEASUREMENT
OF pH IN WATER**

**AUTHORIZED
VERSION:**
09/29/2020
PAGE 1 of 7

PURPOSE	To provide standard instructions for field measurement of pH in water.
SCOPE	Pioneer Technical Services, Inc. (Pioneer) prepared this practice for the workforce and this Standard Operating Procedure (SOP) applies to all work performed by and on behalf of Pioneer. All members of the Pioneer workforce who conduct the work shall be trained and competent (as defined by OSHA) in the risk-assessed procedure described below before performing the work.
WORK INSTRUCTIONS	
<p>The following instructions provide guidance to perform the task in a safe, accurate, and reliable manner. If these instructions present information that is inaccurate or unsafe, personnel must notify the Project Manager, Safety Manager, and the SOP Technical Author to initiate appropriate revisions. Personnel will perform all work under this SOP in a manner that is consistent with procedures and policies described in the appropriate Operation, Maintenance, and Monitoring (O&M) Plan (where applicable), appropriate Site-Specific Health and Safety Plans (SSHASP), and Pioneer Corporate Health and Safety Plan (HASP).</p>	
TASK	INSTRUCTIONS
1. Prepare the pH meter.	<p>Pioneer owns and operates different brands and models of pH field measurement meters. All units, in general, have automatic temperature correction (ATC) capabilities. Prior to using a pH meter, verify that it has the ATC function. User manuals for each meter are available and the specific directions for calibrating and measuring pH with that meter should be followed.</p> <p>Calibrate pH meter in the field at the beginning of each day and if a standard check is out of calibration. Record the calibration information in the field logbook.</p> <ol style="list-style-type: none"> 1. For a new probe, prepare the pH probe according to the directions in the electrode user guide. 2. Connect the probe to the appropriate connection on the meter. 3. Turn the meter on and make sure it is in the pH measurement mode. Calibrate instrument as described in the meter-specific operating manual.
2. Calibrate the meter.	<p>The following is a general summary for instrument calibration:</p> <ol style="list-style-type: none"> 1. Rinse the ATC pH probe in deionized water. 2. Turn on meter and immerse the ATC pH probe in a pH 7 buffer solution. Calibrate meter to pH 7 allowing enough time for meter to stabilize. 3. Rinse ATC pH probe with deionized water. 4. Immerse ATC pH probe in a pH 4 buffer solution. Calibrate meter to pH 4 allowing enough time for meter to stabilize.



SOP-WFM-01
FIELD MEASUREMENT
OF pH IN WATER

AUTHORIZED
VERSION:
 09/29/2020
 PAGE 2 of 7

	<ol style="list-style-type: none"> 5. Rinse pH and temperature probe with deionized water. 6. Immerse ATC pH probe in a pH 10 buffer solution. Calibrate meter to pH 10 allowing enough time for meter to stabilize. 7. Record the slope reading in the field logbook. 8. Recheck meter calibrations with the pH 4, pH 7, and pH 10 calibration solutions. Repeat the calibration process (steps 2-6) if a value for any final pH check is outside the manufacturer's stated accuracy as stated in the user's manual
<p>3. Take field measurements.</p>	<p>The following is a general summary for field measurement of pH:</p> <ol style="list-style-type: none"> 1. Rinse beaker with sample water 3 times. 2. Rinse ATC pH probe with deionized water. 3. Fill beaker with sample water. 4. Turn on meter and immerse ATC pH probe in sample water. Stir sample for thorough mixing. Read and record pH to the nearest 0.01 unit once pH reading has stabilized. 5. Rinse electrodes with deionized water and store in carrying case. <p><u>Note:</u> pH may also be measured by placing the probe directly into the water body being tested. The probe must be moved slowly in a circular motion when measuring stagnant water.</p>
<p>Important information about meter.</p>	<ol style="list-style-type: none"> 1. Store meter in case during transport. 2. Check batteries before taking meter into the field. Carry spare batteries and deionized water for rinsing probe. 3. Inspect probe for damage or dirt. 4. Dust and wipe the meter with a damp cloth. If necessary, warm water or mild water-based detergent can be used to clean the case. Immediately remove any spilled substance from the meter using the proper cleaning procedure for the type of spill. 5. If meter readings are erratic, replace the probe. If readings continue to be erratic, return the meter to factory for repair.



**SOP-WFM-01
FIELD MEASUREMENT
OF pH IN WATER**

**AUTHORIZED
VERSION:
09/29/2020
PAGE 3 of 7**

HEALTH SAFETY SECURITY ENVIRONMENT (HSSE) CONSIDERATIONS

This section to be completed with concurrence from the Safety and Health Manager.

SOURCE	HAZARDS	WHERE	HOW, WHEN, RESULT	CONTROLS
CHEMICAL	Potential contact with contaminated water.	Testing sites, during pH measurements.	Inadvertent exposure to contaminated water could lead to adverse health effects.	Personnel will practice proper personal hygiene – wash hands prior to eating/drinking and when leaving the site. Personnel will wear nitrile gloves and safety glasses when taking measurements.
	Potential contact with pH buffer solutions.	Equipment calibration.	Inadvertent exposure to pH buffer solutions could lead to adverse health effects (e.g., irritation of eye, skin, and/or respiratory tract).	Personnel will practice proper personal hygiene – wash hands prior to eating and after calibrating equipment. Personnel will wear nitrile gloves and safety glasses when handling pH buffer solutions.
NOISE	Not applicable.			
ELECTRICAL	Not applicable.			
BODY MECHANICS	Bending, squatting, and kneeling.	During pH measurements.	Bending, squatting, and kneeling during pH measurements could result in muscle/back strains or other injuries.	Personnel should stretch prior to starting work and they will take breaks when necessary.
	Drowning and/or entrapment hazards.	Bodies of water, during pH measurements.	If personnel need to stand in bodies of water to take measurements, they could be exposed to drowning and/or entrapment hazards from soft soils and/or sudden changes in depth of water.	If necessary, personnel will use rods to test soil stability and/or depth of water as they walk to sample locations. Additionally, personnel may be required to wear life vests when crossing deeper bodies of water. When possible, personnel will not enter the water body and take measurements from the bank.



**SOP-WFM-01
FIELD MEASUREMENT
OF pH IN WATER**

**AUTHORIZED
VERSION:**
09/29/2020
PAGE 4 of 7

HEALTH SAFETY SECURITY ENVIRONMENT (HSSE) CONSIDERATIONS

This section to be completed with concurrence from the Safety and Health Manager.

<i>SOURCE</i>	<i>HAZARDS</i>	<i>WHERE</i>	<i>HOW, WHEN, RESULT</i>	<i>CONTROLS</i>
GRAVITY	Falls from slips and trips.	Uneven terrain, slick/muddy/wet surfaces and steep slopes.	Walking/working on slick/muddy/wet and uneven terrain could cause slips and trips resulting in falls and injuries.	Personnel will wear work boots with good traction and ankle support. Personnel will be aware of working/walking surfaces and choose a path to avoid hazards. Keep work areas as dry as possible. Wear muck boots, as necessary.
WEATHER	Cold/heat stress.	Sites.	Exposure to cold climates may result in cold burns, frostbites, and hypothermia. Exposure to high temperatures may result in heat cramps, heat exhaustion, or heat stroke.	Training on signs and symptoms of cold/heat stress is required. Personnel will wear appropriate clothing when working outdoors. Personnel will remain hydrated and will have sufficient caloric intakes during the day. Personnel will follow procedures outlined in applicable SSHASP and/or Pioneer corporate HASP.
	Hypothermia/frostbite.	Sites where air temperature is 35.6 °F (2 °C) or less.	Personnel who become immersed in water or whose clothing becomes wet may be exposed to hypothermia and/or frostbite.	Personnel will change clothing if it becomes wet. When applicable, Personnel will wear waders to prevent clothing from getting wet.
	Lightning.	Outdoor sites.	Electrocution, injury, death, or equipment damage could be caused by lightning strike.	Personnel will follow the 30/30 rule during lightning storms.
RADIATION	Ultraviolet (UV) radiation.	Outdoors.	Personnel could be exposed to UV radiation during summer months causing sun burns, skin damage, and eye damage.	Personnel will wear safety glasses with tinted lenses, long-sleeve work shirts, and long pants. Personnel should wear sunscreen, if necessary.



**SOP-WFM-01
FIELD MEASUREMENT
OF pH IN WATER**

**AUTHORIZED
VERSION:
09/29/2020
PAGE 5 of 7**

HEALTH SAFETY SECURITY ENVIRONMENT (HSSE) CONSIDERATIONS

This section to be completed with concurrence from the Safety and Health Manager.

SOURCE	HAZARDS	WHERE	HOW, WHEN, RESULT	CONTROLS
BIOLOGICAL	Plants, insects, and animals.	Sites.	Exposure to plants, insects, and/or animals may cause rashes, blisters, redness, and swelling.	Training on the signs and symptoms of exposure to plants, insects, and animals is required. Avoid contact with plants, insects, and animals. First-aid kits will be available on site. Personnel with allergies will notify their supervisor.
MECHANICAL	Not applicable.			
PRESSURE	Not applicable.			
THERMAL	Not applicable.			
HUMAN FACTORS	Inexperienced and improperly trained personnel.	Sites.	Inexperienced personnel and improper training could cause incidents resulting in adverse health effects and/or property damage.	Personnel will be properly trained in this procedure and other applicable procedures. Personnel will implement stop work procedures, if necessary.
SIMOPS (Simultaneous Operations)	Not applicable.			



**SOP-WFM-01
FIELD MEASUREMENT
OF pH IN WATER**

**AUTHORIZED
VERSION:**
09/29/2020
PAGE 6 of 7

ADDITIONAL HSSE CONSIDERATIONS

This section to be completed with concurrence from the Safety and Health Manager.

REQUIRED PPE	Personal Protection Equipment (PPE): Hard hat, safety glasses, high-visibility work shirt or vest, long pants, work boots, and nitrile gloves.
APPLICABLE SDSs	Safety Data Sheets (SDSs): pH 4, pH7, and pH10 buffer solutions. Safety Data Sheets are available to Pioneer personnel at the link below: https://pioneertechnicalservices.sharepoint.com/Safety/SafetyDataSheets
REQUIRED PERMITS/ FORMS	Per site/project requirements.
ADDITIONAL TRAINING	Per site/project requirements.

DRAWINGS, DOCUMENTS, AND TOOLS/EQUIPMENT

The following documents should be referenced to assist in completing the associated task.

DRAWINGS	Map with site location and sample locations.
RELATED SOPs/ PROCEDURES/ WORK PLANS	
TOOLS/ EQUIPMENT	pH field measurement meters, spare batteries for the pH field measurement meters, deionized water, pH 7 buffer solution, pH 4 buffer solution, pH 10 buffer solution, beaker, and field logbook.
FORMS/ CHECKLIST	





SOP-WFM-01
FIELD MEASUREMENT
OF pH IN WATER

AUTHORIZED
VERSION:
09/29/2020
PAGE 7 of 7

APPROVALS/CONCURRENCE

By signing this document, all parties acknowledge the completeness and applicability of this SOP for its intended purpose. Also, by signing this document, it serves as acknowledgement that I have received training on the procedure and associated competency testing.

SOP TECHNICAL AUTHOR	DATE
 Julie Flammang	09/29/2020
SAFETY AND HEALTH MANAGER	DATE
 Tara Schleeman	09/29/2020



SOP-WFM-02
FIELD MEASUREMENT
OF OXIDATION REDUCTION
POTENTIAL IN WATER

AUTHORIZED
VERSION:
 10/15/2020
 PAGE 1 of 9

PURPOSE	To provide standard instructions for field measurements of oxidation reduction potential (ORP) in water.
SCOPE	Pioneer Technical Services, Inc. (Pioneer) prepared this practice for the workforce and this Standard Operating Procedure (SOP) applies to all work performed by and on behalf of Pioneer. All members of the Pioneer workforce who conduct the work shall be trained and competent (as defined by OSHA) in the risk-assessed procedure described below before performing the work.
WORK INSTRUCTIONS	
<p>The following instructions provide guidance to perform the task in a safe, accurate, and reliable manner. If these instructions present information that is inaccurate or unsafe, personnel must notify the Project Manager, Safety Manager, and the SOP Technical Author to initiate appropriate revisions. Personnel will perform all work under this SOP in a manner that is consistent with procedures and policies described in the appropriate Operation, Maintenance, and Monitoring (O&M) Plan (where applicable), appropriate Site-Specific Health and Safety Plans (SSHASP), and Pioneer Corporate Health and Safety Plan (HASP).</p>	
TASK	INSTRUCTIONS
Important information about meter's calibration.	<p>Pioneer owns and operates different brands and models of ORP field measurement meters. At this time, Pioneer uses YSI, In-Situ, Thermo Scientific ORION (Orion 3 Star or Orion 5 Star) Portable Meters for ORP measurements. An Orion 9179BNMD epoxy low maintenance ORP/ATC Triode is attached to the ORION meters. The Orion Star meters can perform an automatic ORP calibration adjusted for temperature. User manuals for each meter are available and the specific directions for calibrating and measuring ORP with that meter should be followed.</p> <p>If there is a choice between measuring ORP in the millivolt (mV) or relative millivolt (RmV), measure in mV mode. The Orion meters are calibrated using RmV mode and then changed to mV for measuring. The YSI and In-Situ multi probes, units will be in mV for both calibration and measurements. The mV values can be compared among multiple meters and electrode systems.</p> <p>Listed below is the general calibration procedure. Refer to the meter specific operating manual for detailed calibration instructions.</p>
1. Prepare electrode.	<ol style="list-style-type: none"> 1. Remove the protective shipping cap from the sensing element and save the cap for storage. 2. Clean any salt deposits from the exterior of the electrode by rinsing with distilled water. 3. Shake the electrode downward (similar to a clinical thermometer) to remove air bubbles from the Orion and YSI probes. 4. Connect the electrode to the meter.



SOP-WFM-02
FIELD MEASUREMENT
OF OXIDATION REDUCTION
POTENTIAL IN WATER

AUTHORIZED
VERSION:
 10/15/2020
 PAGE 2 of 9

<p>2. Connect the electrode to the meter.</p>	<ol style="list-style-type: none"> 1. For the Orion meters, insert the ORP connector (large diameter) in the pH or BNC electrode input jack on the meter and the reference electrode connector (small diameter) into the reference electrode input jack. 2. For the YSI and In-Situ meters, slide probe into correct slot and turn counterclockwise to tighten. Make sure threads are not cross threaded and tighten. Hand tighten only!
<p>3. Calibrate the meter.</p>	<p>All field meters must be calibrated prior to use. Calibration shall be performed at a minimum of once per day when the instrument is in use. Calibration shall be performed prior to the first measurements of the day. All calibration results will be recorded in the field logbook, or if stored on the meter, downloaded and saved in the project file. Downloaded calibration files will be included as part of the field logbook record.</p> <ol style="list-style-type: none"> 1. For the Orion meters, set the meter to the RmV mode referring to the specific meter’s user guide for instructions. If using YSI or In-Situ meters skip to step 2. 2. Rinse the electrode with deionized or distilled water and place the ORP electrode in an appropriate ORP standard. Pioneer uses a 400 mV standard (Orion 967901 or similar) for most calibrations. If project-specific measurements of ORP are expected to be much higher or lower than 400 mV, use an ORP calibration standard with an appropriate concentration. Always use fresh ORP standard for calibrations. Empty the ORP calibration container in the Pioneer Calibration Kit, rinse the bottle with fresh ORP solution, empty it, and then pour enough of the calibration fluid into the bottle to cover the bottom of the electrode. 3. For Orion meters, wait for the RmV icon to quit flashing. If using YSI or In-Situ meters, wait for mV to stabilize and accept calibration. 4. The Orion Star meters will automatically calculate the mV. Small adjustments may be required to the reading to achieve the mV value of the ORP standard at the measured temperature. Information provided in the Thermo Orion User Guide for Redox/ORP Electrodes or Table 1, on page 4, can be used as a reference for the appropriate reading. Adjust the meter referring to the meter user’s guide for detailed instructions on adjusting the reading. 5. For Orion meters, press the measure symbol to end the calibration. The mV offset will be displayed and the meter will proceed to the measurement mode. The In-situ meter will display the mV offset and temperature immediately after accepting the calibration. This information can be stored for downloading. 6. If using the YSI meter, calibration is stored on the meter and can be downloaded. To access the calibration information immediately to record in the logbook, return to the main display screen. Press “File,” scroll down to the “GLP” file, and press enter to view. The information from the latest calibration will be displayed at the top. Scroll down to view previous calibrations.



SOP-WFM-02
FIELD MEASUREMENT
OF OXIDATION REDUCTION
POTENTIAL IN WATER

AUTHORIZED
VERSION:
 10/15/2020
 PAGE 3 of 9

	<p>7. Record the calibration information in the logbook or save for later download.</p>
<p>4. Conduct field measurements.</p>	<p>Field ORP measurements for surface water may be made by direct submersion of the instrument probe into the sample stream. If flow is turbulent or shallow, or if direct immersion could damage the probe, a grab sample can be collected in a beaker or bottle and the probe should be placed immediately into the beaker for measurement.</p> <p>Field ORP measurements of groundwater may be made by inserting the probe into a flow-through device or by collection of a grab sample and immediate analysis of that sample in the field. Specific requirements may be listed in the project-specific documents (sampling and analysis plan, quality assurance project plan, work plan, etc.). The ORP measurements are considered stable during groundwater sampling when 3 consecutive readings vary by no more than 10 mV units.</p> <p>Oxidation Reduction Potential is always measured and reported in mV. Refer to the meter specific user manual for measurement instructions. Listed below are general measurement instructions:</p> <ol style="list-style-type: none"> 1. Rinse the electrode with distilled or deionized water. Shake off any excess water and blot the electrode dry with lint-free tissue. 2. Check and make sure that the meter is measuring in mVs. 3. Place the electrode directly into the water to be measured. If the probe cannot be placed directly into the water being measured, rinse a decontaminated beaker with sample water 3 times and fill the beaker with the water to be measured. 4. Continuously stir or move the probe through the sample at a rate of about 1 foot per second. 5. If the meter is in the continuous measurement mode, it will start reading immediately and continuously update the display. The mV icon will flash until the reading is stable. 6. Read and record the result in the field logbook or on a field data sheet. 7. Remove the electrode from the sample, rinse it with distilled or deionized water, and blot it dry before inserting the probe into the storage sleeve.
<p>Important information about the meter.</p>	<ol style="list-style-type: none"> 1. Store meter in its case during transport. 2. Check batteries before taking meter into the field. Carry spare batteries and deionized water for rinsing probe. 3. Inspect probe for damage or dirt.



**SOP-WFM-02
FIELD MEASUREMENT
OF OXIDATION REDUCTION
POTENTIAL IN WATER**

**AUTHORIZED
VERSION:
10/15/2020
PAGE 4 of 9**

- 4. Dust and wipe the meter with a damp cloth. If necessary, warm water or mild water-based detergent can be used to clean the case. Immediately remove any spilled substance from the meter using the proper cleaning procedure for the type of spill.
- 5. If meter readings are erratic, replace the probe. If measurement readings continue to be erratic, return the meter to factory for repair.

Table 1. ORP Standard Values – Page 1

Table 1– ORP Standard Values

Absolute mV values may vary by ± 60 mV

Temperature (°C)	E _H Value (mV)	Absolute Value with Cat. No. 900011 Filling Solution (mV)	Absolute Value with Cat. No. 900001 Filling Solution (mV)
0	438	218	176
1	437	218	176
2	437	218	176
3	436	218	176
4	435	218	176
5	435	218	176
6	434	218	176
7	433	218	176
8	433	218	175
9	432	219	175



SOP-WFM-02
FIELD MEASUREMENT
OF OXIDATION REDUCTION
POTENTIAL IN WATER

AUTHORIZED
VERSION:
 10/15/2020
 PAGE 5 of 9

Table 1. ORP Standard Values – Page 2

Temperature (°C)	E_H Value (mV)	Absolute Value with Cat. No. 900011 Filling Solution (mV)	Absolute Value with Cat. No. 900001 Filling Solution (mV)
10	431	219	175
11	430	219	175
12	430	219	175
13	429	219	175
14	428	219	175
15	428	219	175
16	427	219	174
17	426	219	174
18	425	219	174
19	424	219	174
20	424	219	174
21	423	219	174
22	422	219	174
23	421	219	173
24	420	220	173
25	420	220	173
26	419	220	173
27	418	220	173
28	417	220	172
29	416	220	172
30	415	220	172
31	414	220	172
32	413	220	172
33	412	220	171
34	412	220	171
35	411	220	171
36	410	220	171
37	409	220	171
38	408	220	170
39	407	220	170
40	406	220	170
41	405	220	170
42	404	220	169
43	403	220	169
44	402	220	169
45	401	220	169
46	400	220	168
47	399	220	168
48	398	220	168
49	397	220	168
50	396	220	167



SOP-WFM-02
FIELD MEASUREMENT
OF OXIDATION REDUCTION
POTENTIAL IN WATER

AUTHORIZED
VERSION:
 10/15/2020
 PAGE 6 of 9

HEALTH SAFETY SECURITY ENVIRONMENT (HSSE) CONSIDERATIONS

This section to be completed with concurrence from the Safety and Health Manager.

SOURCE	HAZARDS	WHERE	HOW, WHEN, RESULT	CONTROLS
CHEMICAL	Potential contact with contaminated water.	Testing sites, during field measurements.	Inadvertent exposure to contaminated water could lead to adverse health effects.	Personnel will practice proper personal hygiene – wash hands prior to eating/drinking and when leaving the site. Personnel will wear nitrile gloves and safety glasses when taking measurements.
	Potential exposure to ORP standard solution.	Equipment calibration.	ORP standard solution is moderately toxic if ingested. It may also irritate eyes and skin.	Personnel will practice proper personal hygiene – wash hands prior to eating and after calibrating equipment. Personnel will wear nitrile gloves and safety glasses when handling the ORP standard solution.
NOISE	Not applicable.			
ELECTRICAL	Not applicable.			
BODY MECHANICS	Bending, squatting, and kneeling.	During field measurements.	Bending, squatting, and kneeling during field measurements could result in muscle/back strains or other injuries.	Personnel should stretch prior to starting work and they will take breaks when necessary.
	Drowning and/or entrapment hazards.	Bodies of water, during field measurements.	If personnel need to stand in bodies of water to take measurements, they could be exposed to drowning and/or entrapment hazards from soft soils and/or sudden changes in depth of water.	If necessary, personnel will use rods to test soil stability and/ or depth of water as they walk to sample locations. Also, personnel may be required to wear life vests when crossing deeper bodies of water. When possible, personnel will not enter the water body and take measurements from the bank.



**SOP-WFM-02
FIELD MEASUREMENT
OF OXIDATION REDUCTION
POTENTIAL IN WATER**

**AUTHORIZED
VERSION:**
10/15/2020
PAGE 7 of 9

HEALTH SAFETY SECURITY ENVIRONMENT (HSSE) CONSIDERATIONS

This section to be completed with concurrence from the Safety and Health Manager.

SOURCE	HAZARDS	WHERE	HOW, WHEN, RESULT	CONTROLS
GRAVITY	Falls from slips and trips.	Uneven terrain, slick/muddy/wet surfaces and steep slopes.	Walking/working on slick/muddy/wet and uneven terrain could cause slips and trips resulting in falls and injuries.	Personnel will wear work boots with good traction and ankle support. Personnel will be aware of working/walking surfaces and choose a path to avoid hazards. Keep work areas as dry as possible. Wear muck boots, as necessary.
WEATHER	Cold/heat stress.	Sites.	Exposure to cold climates may result in cold burns, frostbites, and hypothermia. Exposure to high temperatures may result in heat cramps, heat exhaustion, or heat stroke.	Training on signs and symptoms of cold/heat stress is required. Personnel will wear appropriate clothing when working outdoors. Personnel will remain hydrated and will have sufficient caloric intakes during the day. Personnel will follow procedures outlined in applicable SSHASP and/or Pioneer corporate HASP.
	Hypothermia/frostbite.	Sites where air temperature is 35.6 °F (2 °C) or less.	Personnel who become immersed in water or whose clothing becomes wet may be exposed to hypothermia and/or frostbite.	Personnel will change clothing if it becomes wet. When applicable, Personnel will wear waders to prevent clothing from getting wet.
	Lightning.	Outdoor sites.	Electrocution, injury, death, or equipment damage could be caused by lightning strike.	Personnel will follow the 30/30 rule during lightning storms.
RADIATION	Ultraviolet (UV) radiation.	Outdoors.	Personnel could be exposed to UV radiation during summer months causing sun burns, skin damage, and eye damage.	Personnel will wear safety glasses with tinted lenses, long-sleeve work shirts, and long pants. Personnel should wear sunscreen, if necessary.



**SOP-WFM-02
FIELD MEASUREMENT
OF OXIDATION REDUCTION
POTENTIAL IN WATER**

**AUTHORIZED
VERSION:**
10/15/2020
PAGE 8 of 9

HEALTH SAFETY SECURITY ENVIRONMENT (HSSE) CONSIDERATIONS

This section to be completed with concurrence from the Safety and Health Manager.

SOURCE	HAZARDS	WHERE	HOW, WHEN, RESULT	CONTROLS
BIOLOGICAL	Plants, insects, and animals.	Sites.	Exposure to plants, insects, and/or animals may cause rashes, blisters, redness, and swelling.	Training on the signs and symptoms of exposure to plants, insects, and animals is required. Avoid contact with plants, insects, and animals. First-aid kits will be available on site. Personnel with allergies will notify their supervisor.
MECHANICAL	Not applicable.			
PRESSURE	Not applicable.			
THERMAL	Not applicable.			
HUMAN FACTORS	Inexperienced and improperly trained personnel.	Sites.	Inexperienced personnel and improper training could cause incidents resulting in adverse health effects and/or property damage.	Personnel will be properly trained in this procedure and other applicable procedures. Personnel will implement stop work procedures, if necessary.
SIMOPS (Simultaneous Operations)	Not applicable.			

ADDITIONAL HSSE CONSIDERATIONS

This section to be completed with concurrence from the Safety and Health Manager.

REQUIRED PPE	Personal Protection Equipment (PPE): Hard hat, safety glasses, high-visibility work shirt or vest, long pants, work boots, and nitrile gloves.
APPLICABLE SDSs	Safety Data Sheets (SDSs): ORP Standard Solution Safety Data Sheets are available to Pioneer personnel at the link below: https://pioneertechnicalservices.sharepoint.com/Safety/SafetyDataSheets





**SOP-WFM-02
FIELD MEASUREMENT
OF OXIDATION REDUCTION
POTENTIAL IN WATER**

**AUTHORIZED
VERSION:**
10/15/2020
PAGE 9 of 9

REQUIRED PERMITS/FORMS	Per site/project requirements.
ADDITIONAL TRAINING	Per site/project requirements.

DRAWINGS, DOCUMENTS, AND TOOLS/EQUIPMENT	
The following documents should be referenced to assist in completing the associated task.	
DRAWINGS	Map with site location and sample locations.
RELATED SOPs/ PROCEDURES/ WORK PLANS	
TOOLS/ EQUIPMENT	ORP field measurement meters, ORP standard solution, spare batteries for the meters, distilled water or deionized water, lint-free tissue, beaker, and field logbook or field data sheet.
FORMS/ CHECKLIST	

APPROVALS/CONCURRENCE	
By signing this document, all parties acknowledge the completeness and applicability of this SOP for its intended purpose. Also, by signing this document, it serves as acknowledgement that I have received training on the procedure and associated competency testing.	
SOP TECHNICAL AUTHOR	DATE
 Julie Flammang	10/15/2020
SAFETY AND HEALTH MANAGER	DATE
 Tara Schleeman	10/15/2020



**SOP-WFM-03;
FIELD MEASUREMENT
OF SPECIFIC CONDUCTANCE**

DATE ISSUED:
12/17/2014
REVISION: 0
PAGE 1 of 7

PURPOSE	To provide standard instructions for field measurements of specific conductance.
SCOPE	This practice has been prepared for the Pioneer Technical Services, Inc. (Pioneer) workforce and applies to work carried out by and on behalf of Pioneer. All members of the Pioneer workforce who conduct the work shall be trained and competent in the risk-assessed work described below.

WORK INSTRUCTIONS

The following instructions are intended to provide sufficient guidance to perform the task in a safe, accurate, and reliable manner. Should these instructions present information that is inaccurate or unsafe, operations personnel must bring the issue to the attention of the Project Manager and the appropriate revisions made. All work carried under this SOP will be consistent with procedures and policies described in the appropriate Operation, Maintenance, and Monitoring (O&M) Plan (where applicable), appropriate Site-Specific Health and Safety Plan (SSHASP), and Pioneer Corporate Health and Safety Plan (HASP).

TASK	INSTRUCTIONS
Important information about the meter.	Pioneer owns and operates different brands and models of specific conductance (SC) field measurement meters. All the units, in general, have automatic temperature correction (ATC) capabilities. Prior to using a SC meter check that it does have the ATC function. User manuals for each meter are available and the specific directions for calibrating and measuring SC with that meter should be followed. The following is a general summary for field measurement of SC.
1. Calibrate the meter.	<p>All field meters must be calibrated prior to use. Calibration shall be performed at a minimum of once per day for each day of instrument use. Calibration shall be performed prior to the first measurements of the day. Refer to the meter specific operating manual for calibration instructions. Listed below are general calibration requirements:</p> <ol style="list-style-type: none"> 1. For a new probe, prepare the SC probe according to the directions in the electrode user guide. 2. Connect the probe to the appropriate connection on the meter. 3. Turn the meter on and make sure it is in the conductivity measurement mode. Calibrate instrument as described in the meter specific operating manual. Unless specified in the Sampling and Analysis Plan (SAP) or work plan, one conductivity standard is used for calibration. Unless directed otherwise, use the 1413 micromhos/centimeter ($\mu\text{s}/\text{cm}$) calibration standard present in all of Pioneer's calibration cases. Make sure that the calibration standard in the case is fresh. The container of calibration standard should be emptied, rinsed with new calibration standard and filled prior to a field sampling event. Replace batteries and try fresh calibration solutions if meter does not calibrate properly. 4. Record the calibration results in the field logbook. If the meter displays an average calculated cell constant, record this in the field logbook. 5. Once the SC meter is in measure mode, measure the calibration standard and



**SOP-WFM-03;
FIELD MEASUREMENT
OF SPECIFIC CONDUCTANCE**

DATE ISSUED:
12/17/2014
REVISION: 0
PAGE 2 of 7

	<p>record this result and the measurement temperature in the field logbook.</p> <p>6. Re-measure the calibration fluid at the end of the day and note any drift. Record the information in the field logbook.</p>
<p>2. Conduct field measurements.</p>	<p>Field conductivity measurements for surface water may be made by direct submersion of the instrument probe into the sample stream. When flow is turbulent or shallow, or when direct immersion of the probe would risk damaging the probe, measurements may be made by collection of a grab sample and immediate analysis of the grab sample in the field.</p> <p>Field SC measurements of groundwater may be made by inserting the probe into a flow through device or by collection of a grab sample and immediate analysis of the grab sample in the field. Specific requirements may be listed in the SAP or work plan.</p> <p>Field SC is measured in units of $\mu\text{S}/\text{cm}$ (micromhos/centimeter) or mS/cm (millihos/centimeters) on all Pioneer meters. Refer to the meter specific operating manual for measurement instructions. Listed below are general measurement instructions:</p> <ol style="list-style-type: none"> 1. If the probe cannot be placed directly into the water being measured, rinse the decontaminated beaker with sample water three times. 2. Fill the beaker with the water to be measured. 3. With the meter in measurement mode, rinse the conductivity cell with distilled water, blot dry with a lint-free tissue and place the cell into the water being measured. 4. Submerge conductivity probe in sample so that flow cell holes are immersed and wait for the readings to stabilize. 5. Read and record the SC result in the field logbook or on a field data sheet making sure that the correct units are recorded, either $\mu\text{S}/\text{cm}$ or mS/cm. Record the sample temperature to the nearest 0.1 degree Celsius ($^{\circ}\text{C}$) from the conductivity meter after temperature has equilibrated. 6. Repeat the above steps for all samples. 7. When all samples have been measured, store the electrode according to their specific user guides.
<p>Important information about the meter.</p>	<ol style="list-style-type: none"> 1. Store meter in case during transport. 2. Check batteries before taking meter into the field. Carry spare batteries and de-ionized water for rinsing probe. 3. Inspect probe for damage or dirt.



**SOP-WFM-03;
FIELD MEASUREMENT
OF SPECIFIC CONDUCTANCE**

DATE ISSUED:
12/17/2014
REVISION: 0
PAGE 3 of 7

4. Dust and wipe the meter with a damp cloth. If necessary, warm water or mild water based detergent can be used to clean the case. Immediately remove any spilled substance from the meter using the proper cleaning procedure for the type of spill.
5. If meter readings are erratic, replace the probe. If readings continue to be erratic, return the meter to factory for repair.



**SOP-WFM-03;
FIELD MEASUREMENT
OF SPECIFIC CONDUCTANCE**

DATE ISSUED:
12/17/2014
REVISION: 0
PAGE 4 of 7

HSSE CONSIDERATIONS				
This section to be completed with concurrence from the Safety and Health Manager.				
<i>SOURCE</i>	<i>HAZARDS</i>	<i>WHERE</i>	<i>HOW, WHEN, RESULT</i>	<i>CONTROLS</i>
CHEMICAL	Potential contact with contaminated water.	Testing sites, during field measurements.	Inadvertent exposure to contaminated water could lead to adverse health effects.	Personnel will practice proper personal hygiene – wash hands prior to eating/drinking and when leaving the site. Personnel will wear nitrile gloves and safety glasses when taking measurements.
	Exposure to 1413 µs/cm calibration standard solution.	Equipment calibration.	The calibration standard solution may cause irritation of eyes and skin.	Personnel will practice proper personal hygiene – wash hands prior to eating and after calibrating equipment. Personnel will wear nitrile gloves and safety glasses when handling the calibration standard solution.
NOISE	Not applicable.			
ELECTRICAL	Not applicable.			
BODY MECHANICS	Bending, squatting, and kneeling.	During field measurements.	Bending, squatting, and kneeling during field measurements could result in muscle/back strains or other injuries.	Employees should stretch prior to starting work and they will take breaks when necessary.
	Drowning and/or entrapment hazards.	Bodies of water, during field measurements.	If employees need to stand in bodies of water to take measurements, they could be exposed to drowning and/or entrapment hazards from soft soils and/or sudden changes in depth of water.	If necessary, personnel will use rods to test soil stability and/or depth of water as they walk to sample locations. In addition, personnel may be required to wear life vests when crossing deeper bodies of water. When possible, workers will not enter the water body and take measurements from the bank.



**SOP-WFM-03;
FIELD MEASUREMENT
OF SPECIFIC CONDUCTANCE**

DATE ISSUED:
12/17/2014
REVISION: 0
PAGE 5 of 7

GRAVITY	Falls from slips and trips.	Uneven terrain, slick/muddy/wet surfaces and steep slopes.	Walking/working on slick/muddy/wet and uneven terrain could cause slips and trips resulting in falls and injuries.	Personnel will wear work boots with good traction and ankle support. Personnel will be aware of working/walking surfaces and choose a path to avoid hazards. Keep work areas as dry as possible. Wear muck boots, as necessary.
WEATHER	Cold/heat stress.	Sites.	Exposure to cold climates may result in cold burns, frostbites, and hypothermia. Exposure to high temperatures may result in heat cramps, heat exhaustion, or heat stroke.	Training on signs and symptoms of cold/heat stress is required. Personnel will wear appropriate clothing when working outdoors. Personnel will remain hydrated and will have sufficient caloric intakes during the day. Personnel will follow procedures outlined in applicable SSHASP and/or Pioneer corporate HASP.
	Hypothermia/frostbite.	Sites where air temperature is 35.6°F (2°C) or less.	Workers who become immersed in water or whose clothing becomes wet may be exposed to hypothermia and/or frostbite.	Employees will change clothing if it becomes wet. When applicable, employees will wear waders to prevent clothing from getting wet.
	Lightning.	Outdoor sites.	Electrocution, injury, death, or equipment damage could be caused by lightning strike.	Employees will follow the 30/30 rule during lightning storms.
RADIATION	Ultraviolet (UV) radiation.	Outdoors.	Employees could be exposed to UV radiation during summer months causing sun burns, skin damage, and eye damage.	Employees will wear safety glasses with tinted lenses, long-sleeve work shirts, and long pants. Employees should wear sunscreen, if necessary.



**SOP-WFM-03;
FIELD MEASUREMENT
OF SPECIFIC CONDUCTANCE**

DATE ISSUED:
12/17/2014
REVISION: 0
PAGE 6 of 7

BIOLOGICAL	Plants, insects, and animals.	Sites.	Exposure to plants, insects, and/or animals may cause rashes, blisters, redness, and swelling.	Training on the signs and symptoms of exposure to plants, insects, and animals is required. Avoid contact with plants, insects, and animals. First-aid kits will be available on site. Employees with allergies will notify their supervisor.
MECHANICAL	Not applicable.			
PRESSURE	Not applicable.			
THERMAL	Not applicable.			
HUMAN FACTORS	Inexperienced and improperly trained worker.	Sites.	Inexperienced workers and improper training could cause incidents resulting in adverse health effects and/or property damage.	Employees will be properly trained in this procedure and other applicable procedures. Employees will implement stop work procedures, if necessary.
SIMOPS	Not applicable.			

ADDITIONAL HSSE CONSIDERATIONS

This section to be completed with concurrence from the Safety and Health Manager.

REQUIRED PPE	Hard hat, safety glasses, high-visibility work shirt or vest, long pants, work boots, and nitrile gloves.
APPLICABLE SDS	1413 $\mu\text{s/cm}$ calibration standard solution. Additional Safety Data Sheets (SDSs) will be maintained based on site characterization and contaminants.
REQUIRED PERMITS/FORMS	Per site/project requirements.
ADDITIONAL TRAINING	Per site/project requirements.



**SOP-WFM-03;
FIELD MEASUREMENT
OF SPECIFIC CONDUCTANCE**

DATE ISSUED:
12/17/2014
REVISION: 0
PAGE 7 of 7



DRAWINGS, DOCUMENTS, AND TOOLS/EQUIPMENT

The following documents should be referenced to assist in completing the associated task.

P&IDS	
DRAWINGS	Map with site location and sample locations.
RELATED SOPs/PROCEDURES/ WORK PLANS	
TOOLS	Specific conductance field measurement meter, calibration standard solution, calibration kit, spare batteries for the meter, distilled water or de-ionized water, lint-free tissue, beaker, and field logbook or field data sheet.
FORMS/CHECKLIST	

APPROVALS/CONCURRENCE

By signing this document, all parties acknowledge the completeness and applicability of this SOP for its intended purpose. Also, by signing this document, it serves as acknowledgement that I have received training on the procedure and associated competency testing.

SOP TECHNICAL AUTHOR	DATE
 Julie Flammang	12/17/2014
SAFETY AND HEALTH MANAGER	DATE
 Tara Schleeman	12/17/2014

Revisions:

Revision	Description	Date



SOP-WFM-04
FIELD MEASUREMENT
OF WATER TEMPERATURE

AUTHORIZED
VERSION:
 09/30/2020
 PAGE 1 of 6

PURPOSE	To provide standard instructions for field measurement of water temperature.
SCOPE	Pioneer Technical Services, Inc. (Pioneer) prepared this practice for the workforce and this Standard Operating Procedure (SOP) applies to all work performed by and on behalf of Pioneer. All members of the Pioneer workforce who conduct the work shall be trained and competent (as defined by OSHA) in the risk-assessed procedure described below before performing the work.
WORK INSTRUCTIONS	
The following instructions provide guidance to perform the task in a safe, accurate, and reliable manner. If these instructions present information that is inaccurate or unsafe, personnel must notify the Project Manager, Safety Manager, and the SOP Technical Author to initiate appropriate revisions. Personnel will perform all work under this SOP in a manner that is consistent with procedures and policies described in the appropriate Operation, Maintenance, and Monitoring (O&M) Plan (where applicable), appropriate Site-Specific Health and Safety Plans (SSHASP), and Pioneer Corporate Health and Safety Plan (HASP).	
TASK	INSTRUCTIONS
Note	Pioneer uses a pH field measurement meter or multi-meter for measuring temperature.
1. Prepare the pH meter for measuring water temperature.	<p>Pioneer owns and operates different brands and models of pH and multi-meters. All units, in general, have automatic temperature correction (ATC) capabilities. Prior to using a pH meter or multi-meter, verify that it has the ATC function. User manuals for each meter are available and the specific directions for calibrating and measuring pH with that meter should be followed.</p> <p>Calibrate pH in the field at the beginning of each day. Record the calibration information in the field logbook.</p> <ol style="list-style-type: none"> 1. For a new probe, prepare the pH probe according to the directions in the electrode user guide. 2. Connect the probe to the appropriate connection on the meter. 3. Turn the meter on and make sure it is in the pH measurement mode. Calibrate the instrument as described in the meter-specific operating manual.
2. Calibrate the meter.	<p>The following is a general summary for instrument calibration:</p> <ol style="list-style-type: none"> 1. Rinse the ATC pH probe in deionized water. 2. Turn on meter and immerse the ATC pH probe in a pH 7 buffer solution. Calibrate meter to pH 7 allowing enough time for meter to stabilize. 3. Rinse ATC pH probe with deionized water. 4. Immerse ATC pH probe in a pH 4 buffer solution. Calibrate meter to pH 4



SOP-WFM-04
FIELD MEASUREMENT
OF WATER TEMPERATURE

AUTHORIZED
VERSION:
 09/30/2020
 PAGE 2 of 6

	<p>allowing enough time for meter to stabilize.</p> <ol style="list-style-type: none"> 5. Rinse pH and temperature probe with deionized water. 6. Immerse ATC pH probe in a pH 10 buffer solution. Calibrate meter to pH 10 allowing enough time for meter to stabilize. 7. Record the slope reading in the field logbook. 8. Recheck meter calibrations with the pH 4, pH 7, and pH 10 calibration solutions. Repeat the calibration process (steps 2-6), if a value for any final pH check is more than the manufacture's listed accuracy in the associated user's manual. Record pH and temperature calibration recheck values in logbook.
<p>3. Take field measurements.</p>	<p>The following is a general summary for field measurement of pH and temperature:</p> <ol style="list-style-type: none"> 1. Rinse beaker with sample water 3 times. 2. Rinse ATC pH probe with deionized water. 3. Fill beaker with sample water. 4. Turn on meter and immerse ATC pH probe in sample water. Stir sample for thorough mixing. Read and record temperature to the nearest 0.01 unit once pH and temperature readings have stabilized. 5. Rinse electrodes with deionized water and store in carrying case. <p><u>Note:</u> Temperature may also be measured by placing the probe directly into the water body being tested. The probe must be moved slowly in a circular motion when measuring stagnant water.</p>
<p>Important information about meter.</p>	<ol style="list-style-type: none"> 1. Store meter in case during transport. 2. Check batteries before taking meter into the field. Carry spare batteries and deionized water for rinsing probe. 3. Inspect probe for damage or dirt. 4. Dust and wipe the meter with a damp cloth. If necessary, warm water or a mild water-based detergent can be used to clean the case. Immediately remove any spilled substance from the meter using the proper cleaning procedure for the type of spill. 5. If meter readings are erratic, replace the probe. If readings continue to be erratic, return the meter to factory for repair.



**SOP-WFM-04
FIELD MEASUREMENT
OF WATER TEMPERATURE**

**AUTHORIZED
VERSION:
09/30/2020

PAGE 3 of 6**

HEALTH SAFETY SECURITY ENVIRONMENT (HSSE) CONSIDERATIONS

This section to be completed with concurrence from the Safety and Health Manager.

<i>SOURCE</i>	<i>HAZARDS</i>	<i>WHERE</i>	<i>HOW, WHEN, RESULT</i>	<i>CONTROLS</i>
CHEMICAL	Potential contact with contaminated water.	Testing sites, during temperature measurements.	Inadvertent exposure to contaminated water could lead to adverse health effects.	Personnel will practice proper personal hygiene – wash hands prior to eating/drinking and when leaving the site. Personnel will wear nitrile gloves and safety glasses when taking measurements.
	Potential contact with pH buffer solutions.	Equipment calibration.	Inadvertent exposure to pH buffer solutions could lead to adverse health effects (e.g., irritation of eye, skin, and/or respiratory tract).	Personnel will practice proper personal hygiene – wash hands prior to eating/drinking and after calibrating equipment. Personnel will wear nitrile gloves and safety glasses when handling pH buffer solutions.
NOISE	Not applicable.			
ELECTRICAL	Not applicable.			
BODY MECHANICS	Bending, squatting, and kneeling.	During temperature measurements.	Bending, squatting, and kneeling during temperature measurements could result in muscle/back strains or other injuries.	Personnel should stretch prior to starting work and take breaks when necessary.
	Drowning and/or entrapment hazards.	Bodies of water, during temperature measurements.	If personnel need to stand in bodies of water to take measurements, they could be exposed to drowning and/or entrapment hazards from soft soils and / or sudden changes in depth of water.	If necessary, personnel will use rods to test soil stability and/or depth of water as they walk to sample locations. Additionally, personnel may be required to wear life vests when crossing deeper bodies of water. When possible, personnel will not enter the water body and take measurements from the bank.



**SOP-WFM-04
FIELD MEASUREMENT
OF WATER TEMPERATURE**

**AUTHORIZED
VERSION:
09/30/2020**

PAGE 4 of 6

HEALTH SAFETY SECURITY ENVIRONMENT (HSSE) CONSIDERATIONS

This section to be completed with concurrence from the Safety and Health Manager.

SOURCE	HAZARDS	WHERE	HOW, WHEN, RESULT	CONTROLS
GRAVITY	Falls from slips and trips.	Uneven terrain, slick/muddy/wet surfaces and steep slopes.	Walking/working on slick/muddy/wet and uneven terrain could cause slips and trips resulting in falls and injuries.	Personnel will wear work boots with good traction and ankle support. Personnel will be aware of working/walking surfaces and choose a path to avoid hazards. Keep work areas as dry as possible. Wear muck boots, as necessary.
WEATHER	Cold/heat stress.	Sites.	Exposure to cold climates may result in cold burns, frostbites, and hypothermia. Exposure to high temperatures may result in heat cramps, heat exhaustion, or heat stroke.	Training on signs and symptoms of cold/heat stress is required. Personnel will wear appropriate clothing when working outdoors. Personnel will remain hydrated and will have sufficient caloric intakes during the day. Personnel will follow procedures outlined in applicable SSHASP and/or Pioneer corporate HASP.
	Hypothermia/frostbite.	Sites where air temperature is 35.6 °F (2 °C) or less.	Personnel who become immersed in water or whose clothing becomes wet may be exposed to hypothermia and/or frostbite.	Personnel will change clothing if it becomes wet. When applicable, personnel will wear waders to prevent clothing from getting wet.
	Lightning.	Outdoor sites.	Electrocution, injury, death, or equipment damage could be caused by lightning strike.	Personnel will follow the 30/30 rule during lightning storms.
RADIATION	Ultraviolet (UV) radiation.	Outdoors.	Personnel could be exposed to UV radiation during summer months causing sun burns, skin damage, and eye damage.	Personnel will wear safety glasses with tinted lenses, long-sleeve work shirts, and long pants. Personnel should wear sunscreen, if necessary.



**SOP-WFM-04
FIELD MEASUREMENT
OF WATER TEMPERATURE**

**AUTHORIZED
VERSION:
09/30/2020

PAGE 5 of 6**

HEALTH SAFETY SECURITY ENVIRONMENT (HSSE) CONSIDERATIONS

This section to be completed with concurrence from the Safety and Health Manager.

<i>SOURCE</i>	<i>HAZARDS</i>	<i>WHERE</i>	<i>HOW, WHEN, RESULT</i>	<i>CONTROLS</i>
BIOLOGICAL	Plants, insects, and animals.	Sites.	Exposure to plants, insects, and/or animals may cause rashes, blisters, redness, and swelling.	Training on the signs and symptoms of exposure to plants, insects, and animals is required. Avoid contact with plants, insects, and animals. First-aid kits will be available on site. Personnel with allergies will notify their supervisor.
MECHANICAL	Not applicable.			
PRESSURE	Not applicable.			
THERMAL	Not applicable.			
HUMAN FACTORS	Inexperienced and improperly trained personnel.	Sites.	Inexperienced personnel and improper training could cause incidents resulting in adverse health effects and/or property damage.	Personnel will be properly trained in this procedure and other applicable procedures. Personnel will implement stop work procedures, if necessary.
SIMOPS (Simultaneous Operations)	Not applicable.			

ADDITIONAL HSSE CONSIDERATIONS

This section to be completed with concurrence from the Safety and Health Manager.

REQUIRED PPE	Personal Protection Equipment (PPE): Hard hat, safety glasses, high-visibility work shirt or vest, long pants, work boots, and nitrile gloves.
APPLICABLE SDSs	Safety Data Sheets (SDSs): pH 4, pH 7, and pH 10 buffer solutions. Safety Data Sheets are available to Pioneer personnel at the link below: https://pioneertechnicalservices.sharepoint.com/Safety/SafetyDataSheets





**SOP-WFM-04
FIELD MEASUREMENT
OF WATER TEMPERATURE**

**AUTHORIZED
VERSION:
09/30/2020

PAGE 6 of 6**

REQUIRED PERMITS/ FORMS	Per site/project requirements.
ADDITIONAL TRAINING	Per site/project requirements.

DRAWINGS, DOCUMENTS, AND TOOLS/EQUIPMENT	
The following documents should be referenced to assist in completing the associated task.	
DRAWINGS	Map with site location and sample locations.
RELATED SOPs/ PROCEDURES/ WORK PLANS	
TOOLS/ EQUIPMENT	pH field measurement meters, spare batteries for the pH field measurement meters, deionized water, pH 7 buffer solution, pH 4 buffer solution, pH 10 buffer solution, beaker, and field logbook.
FORMS/ CHECKLIST	

APPROVALS/CONCURRENCE	
By signing this document, all parties acknowledge the completeness and applicability of this SOP for its intended purpose. Also, by signing this document, it serves as acknowledgement that I have received training on the procedure and associated competency testing.	
SOP TECHNICAL AUTHOR	DATE
 Julie Flammang	09/30/2020
SAFETY AND HEALTH MANAGER	DATE
 Tara Schleeman	09/30/2020



**SOP-WFM-05;
STREAMFLOW MEASUREMENT WITH
MARSH MCBIRNEY OR
FLOWTRACKER2® FLOW METER**

**AUTHORIZED VERSION:
04/04/2018
PAGE 1 of 6**

PURPOSE	To provide standard instructions for streamflow measurements with Marsh McBirney and FlowTracker2® flow meters.
SCOPE	This practice has been prepared for the Pioneer Technical Services, Inc. (Pioneer) workforce and applies to work carried out by and on behalf of Pioneer. All members of the Pioneer workforce who conduct the work shall be trained and competent in the risk-assessed work described below.

WORK INSTRUCTIONS

The following instructions are intended to provide sufficient guidance to perform the task in a safe, accurate, and reliable manner. Should these instructions present information that is inaccurate or unsafe, operations personnel must bring the issue to the attention of the Project Manager and the appropriate revisions made. All work carried under this SOP will be consistent with procedures and policies described in the appropriate Operation, Maintenance, and Monitoring (O&M) Plan (where applicable), appropriate Site-Specific Health and Safety Plan (SSHASP), and Pioneer Corporate Health and Safety Plan (HASP).

TASK	INSTRUCTIONS
Note	Measurement of discharge will be accomplished by the velocity - area method utilizing a Marsh McBirney current meter or a FlowTracker2® handheld acoustic doppler current profiler. Locations for the discharge gaging stations will be based on the physical characteristics of the stream reach. Discharge measurement requires a stream section with consistently uniform flow and a static stream bed where dimensions are unlikely to change over the monitoring period. A static stream section is usually found on a straight stream reach at the downstream end of a riffle. For shallow streams with depths less than 2.5 feet, the best velocity - area method is the six-tenths' method. This method measures current velocity at a depth six-tenths of the total depth below the water surface. The procedure is as follows.
1. Assemble the equipment.	Assemble the equipment as per the manufacturer's instructions.
2. Select a section of the stream.	Select a stream section where flows are mostly parallel to the banks, there are no sharp turns in the flow direction, and the bottom is reasonably smooth. The section can be smoothed by reshaping the edges, removing rocks from the bottom, and removing branches, weeds, or grasses prior to beginning the measurement. Set a tag line or cloth tape across the section, perpendicular to the flow. Anchor both ends securely to stakes or other fixed objects.
3. Determine measurement intervals.	Determine the measurement interval size necessary so that no interval has greater than 5% of the flow. Generally, 20 to 25 intervals are adequate depending on the variability and complexity of the stream channel.
4. Take measurements.	Turn on the flow meter. Check the data collection interval per the manufacturer's instruction. Begin measurements at either the left or right bank looking upstream. Note which bank the initial point is located in either the logbook or the field data sheet. The initial point is generally the tape reading at the water line and has no



**SOP-WFM-05;
STREAMFLOW MEASUREMENT WITH
MARSH MCBIRNEY OR
FLOWTRACKER2® FLOW METER**

**AUTHORIZED VERSION:
04/04/2018
PAGE 2 of 6**

	<p>depth or velocity to measure. Measurement points are best set at whole or half-foot intervals.</p> <p>For incised or vertical banks (i.e., a measurement in an engineered or concrete channel) a depth should be measured and set at the bank.</p> <p>Water depth is determined by reading the calibrations on the wading rod. Read depths while ignoring the "pile-up" effect on the upstream portion of the wading rod, which occurs in higher velocity flows. A good rule of thumb is to look at the side of the rod and split the difference of the water elevations on the front and back of the rod.</p> <p>On the marked wading rod, set the probe for the appropriate depth (6/10s method for streams less than 2.5 feet deep or dual depths; 2/10 and 8/10, for streams greater than 2.5 feet) (see operators manual for instructions on setting the probe depth). Care must be taken to keep the meter pointed directly into the flow and to keep the rod in a vertical position. Flow at each station should be measured for at least 15 seconds. Generally, flow will be measured for 30-40 seconds. Flow can be measured for longer intervals as determined by specific project objectives.</p>
5. Record the results.	<p>For the Marsh McBirney, record station, depth, and average velocity on the stream flow field data sheet or in the log book. Calculate the approximate stream flow.</p> <p>For the FlowTracker2®, the handheld will record all data and will calculate the flow at the end of the measurement. Record this total flow, the start/stop time, the location, and any other pertinent information in the log book. Flow can also be viewed at any time during the measurement. Refer to the FlowTracker2® manual for operating procedures.</p>
Note	<p>Very small flows (not exceeding 50 gpm) may be measured using the bucket and stopwatch or float and stopwatch methods. Refer to SOP-WFM-09 Bucket and Stopwatch Method for Measuring Flow for instructions.</p>



**SOP-WFM-05;
STREAMFLOW MEASUREMENT WITH
MARSH MCBIRNEY OR
FLOWTRACKER2® FLOW METER**

**AUTHORIZED VERSION:
04/04/2018
PAGE 3 of 6**

HSSE CONSIDERATIONS This section to be completed with concurrence from the Safety and Health Manager.				
<i>SOURCE</i>	<i>HAZARDS</i>	<i>WHERE</i>	<i>HOW, WHEN, RESULT</i>	<i>CONTROLS</i>
CHEMICAL	Potential contact with contaminated water.	Testing sites, during field measurements.	Inadvertent exposure to contaminated water could lead to adverse health effects.	Personnel will practice proper personal hygiene – wash hands prior to eating/drinking and when leaving the site. Employees will wear nitrile gloves and safety glasses when taking measurements.
NOISE	Not applicable.			
ELECTRICAL	Not applicable.			
BODY MECHANICS	Bending, squatting, and kneeling. Drowning and/or entrapment hazards.	During field measurements. Bodies of water, during field measurements.	Bending, squatting, and kneeling during field measurements could result in muscle/back strains or other injuries. If employees need to stand in bodies of water to take measurements, they could be exposed to drowning and/or entrapment hazards from soft soils and/or sudden changes in depth of water.	Employees should stretch prior to starting work and they will take breaks when necessary. If necessary, workers will use rods to test soil stability and/or depth of water as they walk to sample locations. In addition, personnel may be required to wear life vests when crossing deeper bodies of water. When possible, workers will not enter the water body and take measurements from the bank.
GRAVITY	Falls from slips and trips.	Uneven terrain, slick/muddy/wet surfaces and steep slopes.	Walking/working on slick/muddy/wet and uneven terrain could cause slips and	Workers will wear work boots with good traction and ankle support. Personnel will be aware of working/walking surfaces and choose a path to avoid hazards. Keep work



**SOP-WFM-05;
STREAMFLOW MEASUREMENT WITH
MARSH MCBIRNEY OR
FLOWTRACKER2® FLOW METER**

**AUTHORIZED VERSION:
04/04/2018
PAGE 4 of 6**

			trips resulting in falls and injuries.	areas as dry as possible. Wear muck boots, as necessary.
WEATHER	Cold/heat stress.	Sites.	Exposure to cold climates may result in cold burns, frostbites, and hypothermia. Exposure to high temperatures may result in heat cramps, heat exhaustion, or heat stroke.	Training on signs and symptoms of cold/heat stress is required. Personnel will wear appropriate clothing when working outdoors. Employees will remain hydrated and will have sufficient caloric intakes during the day. Personnel will follow procedures outlined in applicable SSHASP and/or Pioneer corporate HASP.
	Hypothermia/frostbite.	Sites where air temperature is 35.6°F (2°C) or less.	Workers who become immersed in water or whose clothing becomes wet may be exposed to hypothermia and/or frostbite.	Employees will change clothing if it becomes wet. When applicable, employees will wear waders to prevent clothing from getting wet.
	Lightning.	Outdoor sites.	Electrocution, injury, death, or equipment damage could be caused by lightning strike.	Employees will follow the 30/30 rule during lightning storms.
RADIATION	Ultraviolet (UV) radiation.	Outdoors.	Employees could be exposed to UV radiation during summer months causing sun burns, skin damage, and eye damage.	Employees will wear safety glasses with tinted lenses, long-sleeve work shirts, and long pants. Employees should wear sunscreen, if necessary.
BIOLOGICAL	Plants, insects, and animals.	Sites.	Exposure to plants, insects, and/or animals may cause rashes, blisters, redness, and swelling.	Training on the signs and symptoms of exposure to plants, insects, and animals is required. Avoid contact with plants, insects, and animals. First-aid kits will be available



**SOP-WFM-05;
STREAMFLOW MEASUREMENT WITH
MARSH MCBIRNEY OR
FLOWTRACKER2® FLOW METER**

**AUTHORIZED VERSION:
04/04/2018
PAGE 5 of 6**

				on site. Employees with allergies will notify their supervisor.
MECHANICAL	Not applicable.			
PRESSURE	Not applicable.			
THERMAL	Not applicable.			
HUMAN FACTORS	Inexperienced and improperly trained worker.	Sites.	Inexperienced workers and improper training could cause incidents resulting in adverse health effects and/or property damage.	Employees will be properly trained in this procedure and other applicable procedures. Employees will implement stop work procedures, if necessary.
SIMOPS	Not applicable.			

ADDITIONAL HSSE CONSIDERATIONS

This section to be completed with concurrence from the Safety and Health Manager.

REQUIRED PPE	Hard hat, safety glasses, high-visibility work shirt or vest, long pants, work boots, and nitrile gloves.
APPLICABLE SDS	Safety Data Sheets (SDSs) will be maintained based on site characterization and contaminants.
REQUIRED PERMITS/FORMS	Per site/project requirements.
ADDITIONAL TRAINING	Per site/project requirements.

DRAWINGS, DOCUMENTS, AND TOOLS/EQUIPMENT

The following documents should be referenced to assist in completing the associated task.

P&IDS	
DRAWINGS	Map with site location and sample locations.
RELATED SOPs/PROCEDURES/WORK PLANS	SOP-WFM-09 Bucket and Stopwatch Method for Measuring Flow.
TOOLS	Marsh McBirney or FlowTracker2® flow meter, tag line or cloth tape, stakes, extra batteries, and field logbook or field data sheet. Bucket and stopwatch for very slow flows.





**SOP-WFM-05;
STREAMFLOW MEASUREMENT WITH
MARSH MCBIRNEY OR
FLOWTRACKER2® FLOW METER**

**AUTHORIZED VERSION:
04/04/2018
PAGE 6 of 6**

FORMS/CHECKLIST

APPROVALS/CONCURRENCE

By signing this document, all parties acknowledge the completeness and applicability of this SOP for its intended purpose. Also, by signing this document, it serves as acknowledgement that I have received training on the procedure and associated competency testing.

SOP TECHNICAL AUTHOR	DATE
 Julie Flammang	04/04/2018
SAFETY AND HEALTH MANAGER	DATE
 Tara Schleeman	04/04/2018

Revisions:

Revision	Description	Date



**SOP-WFM-07;
FIELD MEASUREMENT OF DISSOLVED
OXYGEN**

DATE ISSUED:
12/17/2014
REVISION: 0
PAGE 1 of 7

PURPOSE	To provide standard instructions for field measurements of dissolved oxygen.
SCOPE	This practice has been prepared for the Pioneer Technical Services, Inc. (Pioneer) workforce and applies to work carried out by and on behalf of Pioneer. All members of the Pioneer workforce who conduct the work shall be trained and competent in the risk-assessed work described below.

WORK INSTRUCTIONS

The following instructions are intended to provide sufficient guidance to perform the task in a safe, accurate, and reliable manner. Should these instructions present information that is inaccurate or unsafe, operations personnel must bring the issue to the attention of the Project Manager and the appropriate revisions made. All work carried under this SOP will be consistent with procedures and policies described in the appropriate Operation, Maintenance, and Monitoring (O&M) Plan (where applicable), appropriate Site-Specific Health and Safety Plan (SSHASP), and Pioneer Corporate Health and Safety Plan (HASP).

TASK	INSTRUCTIONS
Note	Pioneer owns and operates several brands and models of dissolved oxygen (DO) field measurement meters. All the units have automatic barometric pressure and salinity content compensation. User manuals for each meter are available and the specific directions for calibrating and measuring DO with that meter should be followed. The following is a general summary for field measurement of DO.
1. Calibrate the meter.	<p>All field meters must be calibrated prior to use. Calibration shall be performed at a minimum of once per day for each day of instrument use. Calibration shall be performed prior to the first measurements of the day. Refer to the meter specific operating manual for calibration instructions. Listed below are general calibration requirements:</p> <ol style="list-style-type: none"> 1. Inspect DO meter and probe for damage. If one of the YSI DO meters is to be used, inspect the probe for sufficient electrolyte and to determine if the oxygen sensor membrane is in good condition. Replace membrane, if torn or wrinkled. Inspect for air bubbles beneath the membrane. If bubbles are present, remove membrane and add electrolyte solution. Replace membrane so that air bubbles are absent. If the Thermo Scientific DO meters are used, check to make sure the RDO Optical Dissolved Oxygen probe has not exceeded its lifespan. 2. Turn the meter on and if needed place the meter in the DO measurement mode. Calibrate instrument as described in the meter specific operating manual. Unless specified in the Sampling and Analysis Plan (SAP) or work plan, calibration should be conducted in the % saturation mode. Replace batteries and clean probe, if meter does not calibrate properly. 3. With all of Pioneers DO meters, an air calibration is performed in water saturated air using the calibration/storage sleeve. To begin, check the sponge in the calibration sleeve and moisten the sponge with distilled water, if needed. Place 3-6 drops of water on the sponge and then allow any excess water to drain out of the chamber. The wet sponge creates a 100% water saturated air environment for the probe. This environment is ideal for DO calibration and for



**SOP-WFM-07;
FIELD MEASUREMENT OF DISSOLVED
OXYGEN**

DATE ISSUED:
12/17/2014
REVISION: 0
PAGE 2 of 7

	<p>storage of the probe during transport and non-use.</p> <ol style="list-style-type: none"> 4. Allow the probe and calibration standard (water saturated air) to reach equilibrium. 5. Calibrate the meter according to manufacturer's instructions. To accurately calibrate the YSI DO meters you will need to know the following information: <ul style="list-style-type: none"> • The approximate salinity of the water you will be analyzing. Fresh water has a salinity of approximately zero. Seawater has a salinity of approximately 35 parts per thousand (ppt). • For calibration in % saturation mode, the approximate altitude (in feet) of the region where you are located is required. This information can be obtained over the internet or from a topographic map. 6. Record the % saturation number displayed at the end of the automatic calibration.
<p>2. Take measurements.</p>	<p>Field DO measurements for surface water may be made by direct submersion of the instrument probe into the sample stream. If flow is turbulent or shallow, or if direct immersion of the probe would risk damaging the probe, a grab sample can be collected and immediate measurement of the grab sample conducted.</p> <p>Field DO measurements of groundwater may be made by inserting the probe into a flow through device or by collection of a grab sample and immediate analysis of the grab sample in the field. Specific requirements may be listed in the SAP or work plan. The site-specific document may list the units that DO should be measured in (e.g., % saturation or mg/L). Refer to the meter-specific operating manual for measurement instructions. Listed below are general measurement instructions:</p> <ol style="list-style-type: none"> 1. If the probe cannot be placed directly into the water being measured, rinse the decontaminated beaker with sample water three times. 2. Fill the beaker with the water to be measured. 3. Continuously stir or move the probe through the sample at a rate of about one foot per second. 4. Allow temperature and dissolved oxygen readings to stabilize. 5. Read and record the DO result in the field logbook or on a field data sheet making sure that the correct units are recorded (either % Sat or mg/L). Record the sample temperature to the nearest 0.1°C from a pH meter, if available, after the temperature has equilibrated. 6. Spray the probe with de-ionized water and wipe clean before reinserting to calibration/storage sleeve. 7. Repeat the above steps for all samples.



**SOP-WFM-07;
FIELD MEASUREMENT OF DISSOLVED
OXYGEN**

**DATE ISSUED:
12/17/2014
REVISION: 0
PAGE 3 of 7**

	<ol style="list-style-type: none">8. When all samples have been measured, store the electrode according to their specific user guides.
<ol style="list-style-type: none">3. Maintenance of equipment.	<ol style="list-style-type: none">1. Store meter in case during transport.2. Check batteries before taking meter into the field. Carry spare batteries and de-ionized water for rinsing probe.3. Inspect probe for damage or dirt.4. Dust and wipe the meter with a damp cloth. If necessary, use warm water or mild water based detergent to clean the case. Immediately remove any spilled substance from the meter using the proper cleaning procedure for the type of spill.5. If meter readings are erratic, replace the probe. If measurement readings continue to be erratic, return the meter to factory for repair.



**SOP-WFM-07;
FIELD MEASUREMENT OF DISSOLVED
OXYGEN**

DATE ISSUED:
12/17/2014
REVISION: 0
PAGE 4 of 7

HSSE CONSIDERATIONS

This section to be completed with concurrence from the Safety and Health Manager.

<i>SOURCE</i>	<i>HAZARDS</i>	<i>WHERE</i>	<i>HOW, WHEN, RESULT</i>	<i>CONTROLS</i>
CHEMICAL	Potential contact with contaminated water.	Testing sites, during field measurements.	Inadvertent exposure to contaminated water could lead to adverse health effects.	Personnel will practice proper personal hygiene – wash hands prior to eating/drinking and when leaving the site. Personnel will wear nitrile gloves and safety glasses when taking measurements.
NOISE	Not applicable.			
ELECTRICAL	Not applicable.			
BODY MECHANICS	Bending, squatting, and kneeling. Drowning and/or entrapment hazards.	During field measurements. Bodies of water, during field measurements.	Bending, squatting, and kneeling during field measurements could result in muscle/back strains or other injuries. If employees need to stand in bodies of water to take measurements, they could be exposed to drowning and/or entrapment hazards from soft soils and/or sudden changes in depth of water.	Employees should stretch prior to starting work and they will take breaks when necessary. If necessary, workers will use rods to test soil stability and/or depth of water as they walk to sample locations. In addition, personnel may be required to wear life vests when crossing deeper bodies of water. When possible, workers will not enter the water body and take measurements from the bank.
GRAVITY	Falls from slips and trips.	Uneven terrain, slick/muddy/wet surfaces and steep slopes.	Walking/working on slick/muddy/wet and uneven terrain could cause slips and trips resulting in	Personnel will wear work boots with good traction and ankle support. Personnel will be aware of working/walking surfaces and choose a path to avoid hazards. Keep work areas as dry as possible. Wear



**SOP-WFM-07;
FIELD MEASUREMENT OF DISSOLVED
OXYGEN**

DATE ISSUED:
12/17/2014
REVISION: 0
PAGE 5 of 7

			falls and injuries.	muck boots, as necessary.
WEATHER	Cold/heat stress.	Sites.	Exposure to cold climates may result in cold burns, frostbites, and hypothermia. Exposure to high temperatures may result in heat cramps, heat exhaustion, or heat stroke.	Training on signs and symptoms of cold/heat stress is required. Personnel will wear appropriate clothing when working outdoors. Personnel will remain hydrated and will have sufficient caloric intakes during the day. Personnel will follow procedures outlined in applicable SSHASP and/or Pioneer corporate HASP.
	Hypothermia/frostbite.	Sites where air temperature is 35.6°F (2°C) or less.	Workers who become immersed in water or whose clothing becomes wet may be exposed to hypothermia and/or frostbite.	Employees will change clothing if it becomes wet. When applicable, employees will wear waders to prevent clothing from getting wet.
	Lightning.	Outdoor sites.	Electrocution, injury, death, or equipment damage could be caused by lightning strike.	Employees will follow the 30/30 rule during lightning storms.
RADIATION	Ultraviolet (UV) radiation.	Outdoors.	Employees could be exposed to UV radiation during summer months causing sun burns, skin damage, and eye damage.	Employees will wear safety glasses with tinted lenses, long-sleeve work shirts, and long pants. Employees should wear sunscreen, if necessary.
BIOLOGICAL	Plants, insects, and animals.	Sites.	Exposure to plants, insects, and/or animals may cause rashes, blisters, redness, and swelling.	Training on the signs and symptoms of exposure to plants, insects, and animals is required. Avoid contact with plants, insects, and animals. First-aid kits will be available on site. Employees with allergies will notify their supervisor.



**SOP-WFM-07;
FIELD MEASUREMENT OF DISSOLVED
OXYGEN**

DATE ISSUED:
12/17/2014
REVISION: 0
PAGE 6 of 7

MECHANICAL	Not applicable.			
PRESSURE	Not applicable.			
THERMAL	Not applicable.			
HUMAN FACTORS	Inexperienced and improperly trained worker.	Sites.	Inexperienced workers and improper training could cause incidents resulting in adverse health effects and/or property damage.	Employees will be properly trained in this procedure and other applicable procedures. Employees will implement stop work procedures, if necessary.
SIMOPS	Not applicable.			

ADDITIONAL HSSE CONSIDERATIONS

This section to be completed with concurrence from the Safety and Health Manager.

REQUIRED PPE	Hard hat, safety glasses, high-visibility work shirt or vest, long pants, work boots, and nitrile gloves.
APPLICABLE SDS	Safety Data Sheets (SDSs) will be maintained based on site characterization and contaminants.
REQUIRED PERMITS/FORMS	Per site/project requirements.
ADDITIONAL TRAINING	Per site/project requirements.

DRAWINGS, DOCUMENTS, AND TOOLS/EQUIPMENT

The following documents should be referenced to assist in completing the associated task.

P&IDS	
DRAWINGS	Map with site location and sample locations.
RELATED SOPs/PROCEDURES/WORK PLANS	
TOOLS	Dissolved oxygen field measurement meter, de-ionized water, distilled water, decontaminated beaker, field logbook or field data sheet, and spare batteries for meter.
FORMS/CHECKLIST	





**SOP-WFM-07;
FIELD MEASUREMENT OF DISSOLVED
OXYGEN**

**DATE ISSUED:
12/17/2014
REVISION: 0
PAGE 7 of 7**

APPROVALS/CONCURRENCE

By signing this document, all parties acknowledge the completeness and applicability of this SOP for its intended purpose. Also, by signing this document, it serves as acknowledgement that I have received training on the procedure and associated competency testing.

SOP TECHNICAL AUTHOR	DATE
 Julie Flammang	12/17/2014
SAFETY AND HEALTH MANAGER	DATE
 Tara Schleeman	12/17/2014

Revisions:

Revision	Description	Date



**SOP-WFM-08
FIELD TURBIDITY
MEASUREMENT**

**AUTHORIZED
VERSION:**
10/13/2020
PAGE 1 of 9

PURPOSE	To provide standard instructions for field turbidity measurements.
SCOPE	Pioneer Technical Services, Inc. (Pioneer) prepared this practice for the workforce and this Standard Operating Procedure (SOP) applies to all work performed by and on behalf of Pioneer. All members of the Pioneer workforce who conduct the work shall be trained and competent (as defined by OSHA) in the risk-assessed procedure described below before performing the work.
WORK INSTRUCTIONS	
The following instructions provide guidance to perform the task in a safe, accurate, and reliable manner. If these instructions present information that is inaccurate or unsafe, personnel must notify the Project Manager, Safety Manager, and the SOP Technical Author to initiate appropriate revisions. Personnel will perform all work under this SOP in a manner that is consistent with procedures and policies described in the appropriate Operation, Maintenance, and Monitoring (O&M) Plan (where applicable), appropriate Site-Specific Health and Safety Plans (SSHASP), and Pioneer Corporate Health and Safety Plan (HASP).	
TASK	INSTRUCTIONS
Note	The turbidity of the water pumped during well development and sampling or surface water testing will be measured using a portable turbidimeter. Record the calibrations and sampling and stabilization information in the bound logbook, field data sheets, or on the well development data form, as appropriate. The turbidity measurement data for groundwater sampling will include, at a minimum, the well number, date and time, volume of water pumped, and the Nephelometric Turbidity Units (NTU) reading.
Equipment description	A HACH Model Portable Turbidity Meter (HACH Turbidimeter) operates on the nephelometric principle of turbidity measurement and meets EPA Method 180.1. The meter measures turbidity directly in NTU on a precalibrated meter scale. Calibration of the meter is based on an accepted primary standard of turbidity measurement and will be completed per the manufacturer's guidance.
1. Verify standards.	<p>Verify that the turbidimeter is reading the standard cells accurately. This should be done at a minimum of once per day prior to beginning measurements. If based on the verification standards, a calibration is required, perform the calibration.</p> <p>The HACH Turbidimeter verification is accomplished with 4 standards provided in the meter kit by the manufacturer: 10, 20, 100, and 800 NTU. The HACH's accuracy is +/- 2% of the reading. If the turbidity meter being used is not a HACH Turbidimeter, verify accuracy with manufacture's user manual. To verify the standards:</p> <ol style="list-style-type: none"> 1. Place the meter on a flat steady surface. Do not hold the meter during operation. Turn on the meter and let it warm up. 2. Note: Before inserting the calibration cell, make sure that the sample cell is clean. Wipe the sample cell thoroughly with a lint free cloth. If needed, oil the sample cell with silicone oil. To ensure that the standard solutions are well-mixed, gently invert each standard before inserting into the meter. Insert so that the diamond or orientation



	<p>mark aligns with the raised orientation mark in front of the cell compartment.</p> <p>To start the verification process, select “Verify Calibration” and follow the directions on the display. Insert the calibration sample cell marked 10 NTU in the instrument cell compartment, close the lid and press “Read.”</p> <ol style="list-style-type: none">Record the result in the logbook and press “Done.”Clean and gently mix the sample cell marked 20 NTU. Place the sample cell in the instrument cell compartment, close the lid and press “Read.”Record the result in the field logbook and press “Done.”Repeat the process with the remaining 2 standards, 100 and 800 NTU. Make sure to clean and gently invert each calibration cell prior to inserting in the meter. Record the results of each standard in the field logbook.
<p>2. Calibrate instrument.</p>	<p>The HACH Turbidimeter calibration is accomplished using 3 of the verification standards provided in the meter kit.</p> <ol style="list-style-type: none">Place the meter on a flat steady surface. Do not hold the meter during operation. Turn on the meter and let it warm up.Start the calibration process by pushing the “Calibration” key to enter the calibration mode and follow the instructions on the display.Note: Before inserting the calibration cell, make sure that the sample cell is clean. Wipe the sample cell thoroughly with a lint free cloth. If needed, oil the sample cell with silicone oil. To ensure that the standard solutions are well-mixed, gently invert each standard before inserting into the meter. Insert so that the diamond or orientation mark aligns with the raised orientation mark in front of the cell compartment. <p>Insert the calibration sample cell marked 20 NTU in the instrument cell compartment, close the lid and press “Read.”</p> <ol style="list-style-type: none">Record the result in the logbook.Repeat steps 3 and 4 with the 100 NTU and 800 NTU calibration cells. Clean and gently invert each calibration cell prior to inserting in the meter.Push “Done” to review the calibration details and record in logbook.Push “Store” to save results.The meter automatically goes into the “Verify Calibration” mode once the calibration sequence is complete. Insert the 10 NTU Verification Standard and close the lid.



**SOP-WFM-08
FIELD TURBIDITY
MEASUREMENT**

**AUTHORIZED
VERSION:**
10/13/2020
PAGE 3 of 9

	<p>9. Push “Read.” The display shows “Stabilizing” and then shows the result and tolerance range. Record this information in the field logbook.</p> <p>10. Push “Done” to return to the reading display. Repeat the calibration verification if the verification failed.</p> <p>These steps may vary from different models and manufactures. Always refer to manufacture’s user manual.</p>
<p>3. Collect samples.</p>	<p>The HACH Turbidimeter requires collection of a sample for subsequent turbidity measurements. The sample may be collected using any clean container including a sample cell. Rinse sample cells three times with the water to be measured prior to filling the cell for measurement.</p> <p>Collect samples for field measurement purposes by submersion of the sample container into the flow whenever possible.</p> <p>For surface water, always collect samples upstream of sampling personnel and equipment. The sample container should be pointed upstream into the flow when the container is opened for sample collection. Take care not to sample water downstream of areas where sediments have been disturbed in any manner by field personnel.</p> <p>Collect samples from a location where visually the stream flow appears to be completely mixed. Ideally, this is at the center of the flow cross section, but site conditions do not always allow this. Preferably, the location should be accessible by direct reach from the bank or shore, or in the case of a receiving water body, via wading. Caution is required when wading, as flowing water provides more force than visually anticipated.</p> <p>If the center of the flow cannot be sampled by direct reach or by wading into the flow, use a sampling pole or other sampling device to reach the sampling location. Such devices typically involve a way to extend the reach of the sampler, with the sample bottle attached to the end of the device for filling at the desired location.</p> <p>For groundwater, fill the sample cells with sample water directly from the pump tubing during purging activities. Rinse the sample cell three times with purge water prior to sample collection.</p>
<p>4. Take turbidity measurements.</p>	<p>Always cap the sample cell prior to placing in the cell compartment to prevent spillage of the sample into the instrument. Use clean sample cells in good condition. Dirty, scratched, or damaged cells can cause inaccurate readings. Make sure that cold samples do not “fog” the sample cell.</p> <ol style="list-style-type: none"> 1. Collect a representative sample in a clean container. Fill a sample cell to the line (about 15 milliliters). Take care to handle the sample cell by the top. Cap the cell. 2. Wipe the cell with a soft, lint-free cloth to remove water spots and fingerprints. 3. Apply a thin film of silicone oil (provided in meter kit), if needed. Wipe with soft cloth (provided in meter kit) to obtain an even film over the entire surface.



**SOP-WFM-08
FIELD TURBIDITY
MEASUREMENT**

**AUTHORIZED
VERSION:**
10/13/2020
PAGE 4 of 9

	<ol style="list-style-type: none"> 4. Push the “Power” key to turn on the meter. Make sure that the meter is placed on a level, stationary surface during the measurement. Do not hold the meter in the hand during measurement. 5. Gently invert the sample cell to ensure mixing. Insert the sample cell in the instrument cell compartment so the diamond or orientation mark aligns with the raised orientation mark in front of the cell compartment. Close the lid. 6. Push the “Read” key. The display shows “Stabilizing” then displays the turbidity in NTU. 7. Record the value in the field logbook or on the field data form. <p>These steps may vary for different models and manufactures. Always refer to the turbidity meter manufacturer’s user manual.</p> <p>Repeat sample collection and measurement process as required in the sampling and analysis plan or work plan.</p> <p>For groundwater sampling, unless indicated in the project documents, turbidity can be considered stable when 3 consecutive readings are within 10% for values greater than 5 NTU or if 3 consecutive turbidity values are less than 5 NTU.</p> <p>After use, rinse the sample cells with deionized water. Store the sample cells with caps on to prevent cells from drying. Do not air dry the sample cells after use.</p>
<p>5. Store sample cells.</p>	<p>To properly store the sample cells:</p> <ol style="list-style-type: none"> 1. Fill the sample cell with deionized water. 2. Cap the sample cell. 3. Wipe the outside of the sample cell dry with a soft cloth and store the sample cell with the turbidity meter case in such a way as that it will not break during transport.



HEALTH SAFETY SECURITY ENVIRONMENT (HSSE) CONSIDERATIONS

This section to be completed with concurrence from the Safety and Health Manager.

<i>SOURCE</i>	<i>HAZARDS</i>	<i>WHERE</i>	<i>HOW, WHEN, RESULT</i>	<i>CONTROLS</i>
CHEMICAL	Potential contact with contaminated water.	Testing sites, during sample collection and measurements.	Inadvertent exposure to contaminated water could lead to adverse health effects.	Personnel will practice proper personal hygiene – wash hands prior to eating/drinking and when leaving the site. Personnel will wear nitrile gloves and safety glasses when collecting samples and taking measurements.
	20 NTU, 100 NTU, and 800 NTU verification standards.	During equipment calibration.	Personnel can be exposed to verification standards via skin/ eye contact and ingestion/ inhalation when calibrating equipment, which can result in skin/ eye irritation and adverse health effects.	Personnel will prevent skin/ eye contact with verification standards, and they will wear nitrile gloves and safety glasses when handling verification standards. Personnel will practice proper personal hygiene – wash hands prior to eating/ drinking, after equipment calibration, and when leaving the site.
NOISE	Not applicable.			
ELECTRICAL	Not applicable.			
BODY MECHANICS	Bending, squatting, and kneeling.	During sample collection and measurements.	Bending, squatting, and kneeling during sample collection and measurements could result in muscle/ back strains or other injuries.	Personnel should stretch prior to starting work and take breaks when necessary.



HEALTH SAFETY SECURITY ENVIRONMENT (HSSE) CONSIDERATIONS

This section to be completed with concurrence from the Safety and Health Manager.

<i>SOURCE</i>	<i>HAZARDS</i>	<i>WHERE</i>	<i>HOW, WHEN, RESULT</i>	<i>CONTROLS</i>
	Drowning and/or entrapment hazards.	Bodies of water, during sample collection.	If personnel need to stand in bodies of water to collect samples, they could be exposed to drowning and/or entrapment hazards from soft soils and/or sudden changes in depth of water.	If necessary, personnel will use rods to test soil stability and/or depth of water as they walk to sample locations. Additionally, personnel may be required to wear life vests when crossing deeper bodies of water. Caution is required when wading, as flowing water might provide more force than visually anticipated. When possible, personnel will not enter the water body and collect samples from the bank.
GRAVITY	Falls from slips and trips.	Uneven terrain, slick/muddy/ wet surfaces and steep slopes.	Walking/ working on slick/ muddy/ wet and uneven terrain could cause slips and trips resulting in falls and injuries.	Personnel will wear work boots with good traction and ankle support. Personnel will be aware of working/ walking surfaces and choose a path to avoid hazards. Wear muck boots, as necessary.
WEATHER	Cold/heat stress. Hypothermia/frostbite.	Sites. Sites where air temperature is 35.6 °F (2 °C) or less.	Exposure to cold climates may result in cold burns, frostbites, and hypothermia. Exposure to high temperatures may result in heat cramps, heat exhaustion, or heat stroke. Personnel who become immersed in water or whose clothing becomes wet may be exposed to hypothermia and/or frostbite.	Training on signs and symptoms of cold/heat stress is required. Personnel will wear appropriate clothing when working outdoors. Personnel will remain hydrated and will have sufficient caloric intakes during the day. Personnel will follow procedures outlined in applicable SSHASP and/or Pioneer corporate HASP. Personnel will change clothing if it becomes wet. When applicable, personnel will wear waders to prevent clothing from getting wet.



HEALTH SAFETY SECURITY ENVIRONMENT (HSSE) CONSIDERATIONS

This section to be completed with concurrence from the Safety and Health Manager.

<i>SOURCE</i>	<i>HAZARDS</i>	<i>WHERE</i>	<i>HOW, WHEN, RESULT</i>	<i>CONTROLS</i>
	Lightning.	Outdoor sites.	Electrocution, injury, death, or equipment damage could be caused by lightning strike.	Personnel will follow the 30/30 rule during lightning storms.
RADIATION	Ultraviolet (UV) radiation.	Outdoors.	Personnel could be exposed to UV radiation during summer months causing sun burns, skin damage, and eye damage.	Personnel will wear safety glasses with tinted lenses, long-sleeve work shirts, and long pants. Personnel should wear sunscreen, if necessary.
BIOLOGICAL	Plants, insects, and animals.	Sites.	Exposure to plants, insects, and/ or animals may cause rashes, blisters, redness, and swelling.	Training on the signs and symptoms of exposure to plants, insects, and animals is required. Avoid contact with plants, insects, and animals. First-aid kits will be available on site. Personnel with allergies will notify their supervisor.
MECHANICAL	Pinch points.	Well caps.	Personal injury could result from fingers getting pinched when opening/closing well caps.	Personnel will wear work gloves when opening/closing well caps.
PRESSURE	Not applicable.			
THERMAL	Not applicable.			
HUMAN FACTORS	Inexperienced and improperly trained personnel.	Sites.	Inexperienced personnel and improper training could cause incidents resulting in adverse health effects and/or property damage.	Personnel will be properly trained in this procedure and other applicable procedures. Personnel will implement stop work procedures, if necessary.



**SOP-WFM-08
FIELD TURBIDITY
MEASUREMENT**

**AUTHORIZED
VERSION:**
10/13/2020
PAGE 8 of 9

HEALTH SAFETY SECURITY ENVIRONMENT (HSSE) CONSIDERATIONS

This section to be completed with concurrence from the Safety and Health Manager.

<i>SOURCE</i>	<i>HAZARDS</i>	<i>WHERE</i>	<i>HOW, WHEN, RESULT</i>	<i>CONTROLS</i>
SIMOPS (Simultaneous Operations)	Not applicable.			

ADDITIONAL HSSE CONSIDERATIONS

This section to be completed with concurrence from the Safety and Health Manager.

REQUIRED PPE	Personal Protection Equipment (PPE): Hard hat, safety glasses, high-visibility work shirt or vest, long pants, work boots, and nitrile gloves.
APPLICABLE SDSs	Safety Data Sheets (SDSs): 20 NTU, 100 NTU, and 800 NTU verification standards. Safety Data Sheets are available to Pioneer personnel at the link below: https://pioneertechnicalservices.sharepoint.com/Safety/SafetyDataSheets
REQUIRED PERMITS/ FORMS	Per site/project requirements.
ADDITIONAL TRAINING	Per site/project requirements.

DRAWINGS, DOCUMENTS, AND TOOLS/EQUIPMENT

The following documents should be referenced to assist in completing the associated task.

DRAWINGS	Map with site location and sample locations.
RELATED SOPs/ PROCEDURES/ WORK PLANS	
TOOLS/ EQUIPMENT	Turbidimeter and meter kit; bound logbook, field data sheets, or well development data form; clear containers for sample collection; sampling pole or other sampling device (if the center of the flow cannot be sampled by direct reach or by wading into the flow); paper towels; and deionized water.
FORMS/ CHECKLIST	





**SOP-WFM-08
FIELD TURBIDITY
MEASUREMENT**

**AUTHORIZED
VERSION:
10/13/2020
PAGE 9 of 9**

APPROVALS/CONCURRENCE

By signing this document, all parties acknowledge the completeness and applicability of this SOP for its intended purpose. Also, by signing this document, it serves as acknowledgement that I have received training on the procedure and associated competency testing.

SOP TECHNICAL AUTHOR	DATE
 Julie Flammang	10/13/2020
SAFETY AND HEALTH MANAGER	DATE
 Tara Schleeman	10/13/2020



SOP-WFM-09
BUCKET AND STOPWATCH
METHOD FOR MEASURING
FLOW

AUTHORIZED
VERSION:
 10/13/2020
 PAGE 1 of 7

PURPOSE	This document describes general and specific procedures, methods, and considerations to be used and observed when conducting discharge measurements during field investigations.
SCOPE	Pioneer Technical Services, Inc. (Pioneer) prepared this practice for the workforce and this Standard Operating Procedure (SOP) applies to all work performed by and on behalf of Pioneer. All members of the Pioneer workforce who conduct the work shall be trained and competent (as defined by OSHA) in the risk-assessed procedure described below before performing the work.
WORK INSTRUCTIONS	
The following instructions provide guidance to perform the task in a safe, accurate, and reliable manner. If these instructions present information that is inaccurate or unsafe, personnel must notify the Project Manager, Safety Manager, and the SOP Technical Author to initiate appropriate revisions. Personnel will perform all work under this SOP in a manner that is consistent with procedures and policies described in the appropriate Operation, Maintenance, and Monitoring (O&M) Plan (where applicable), appropriate Site-Specific Health and Safety Plans (SSHASP), and Pioneer Corporate Health and Safety Plan (HASP).	
TASK	INSTRUCTIONS
Measuring flow greater than approximately 5 gallons per minute	
Note	The main limitation to this method is that the discharge must fall from a hose, tubing, pipe, or from a drop in a channel in such a way that the collection container can be placed underneath to capture all the discharge. Once flow approaches 300 gallons per minute, alternate methods for determining flow should be considered.
1. Locate the measurement area.	<p>Locate the measurement area and determine what size container would be most appropriate for measuring the flow.</p> <p>If discharge occurs via a channel, then a temporary dam may need to be placed across the channel with the discharge directed through a single outlet. Temporary dams may be constructed from materials present at the site such as rocks or mud, or a temporary flume structure, plastic sheeting, or sandbags can be brought to the site to aid in narrowing the channel. Any dam needs to be removed and the channel returned to pre-blockage flows once measurements are completed.</p>
2. Place collection container directly under the discharge.	<p>Place collection container (e.g., 5-gallon bucket) directly under the discharge.</p> <p>All discharge should flow into the collection container.</p> <p>Note: measurement lines on the container may need to be measured and clearly marked ahead of time.</p>
3. Time discharge with stopwatch.	<p>Time discharge with stopwatch.</p> <p>Time how long it takes to fill the container or to the desired measurement line marked on the container. Record time in logbook.</p>



SOP-WFM-09
BUCKET AND STOPWATCH
METHOD FOR MEASURING
FLOW

AUTHORIZED
VERSION:
 10/13/2020
 PAGE 2 of 7

4. Repeat.	Repeat steps 2 and 3 two more times to obtain a 3-point average.
5. Calculate discharge.	Calculate discharge by following Example 1 calculation (below).

Example 1 Calculation: Calculating Discharge

A 5-gallon bucket is placed under a discharging hose. The bucket fills in 25 seconds, 28 seconds, and 24 seconds.

Calculate average time:

Add the 3 recorded times together and divide by 3 to obtain the average fill time.

$$\text{Average time} = \frac{25 + 28 + 24}{3} = 25.7 \text{ seconds}$$

Convert average time in seconds to minutes:

Divide the average time by 60 seconds per minute to obtain minutes.

$$\text{Average time} = \frac{25.7 \text{ seconds}}{60 \text{ seconds/minute}} = 0.43 \text{ minutes}$$

Calculate the discharge:

Divide the volume of the bucket (gallons) by the average time to fill the bucket (minutes).

$$\text{Discharge} = \frac{5 \text{ gallons}}{0.43 \text{ minutes}} = 11.6 \text{ gallons per minute (gpm)}$$

Source: Estimating Discharge and Stream Flows A Guide for Sand and Gravel Operators, July 2005. Prepared by: Joy P. Michaud and Marlies Wierenga, EnviroVision. Ecology Publication Number 05-10-070.

Measuring flow generally less than 5 gallons per minute

Note	The general procedure listed below is applicable for lower flow volume. The main limitation is that the discharge must fall from a hose, tubing, pipe, or from a drop in a channel in such a way that the collection container can be placed underneath to capture all the discharge.
1. Locate the measurement area.	<p>Locate the measurement area and determine what size container would be most appropriate for measuring the flow.</p> <p>If discharge occurs via a channel, then a temporary dam may need to be placed across the channel with the discharge directed through a single outlet. Temporary dams may be constructed from materials present at the site such as rocks or mud, or a temporary flume structure, plastic sheeting, or sandbags can be brought to the site to aid in narrowing the channel. Any dam needs to be removed and the channel returned to pre-blockage flows once measurements are completed.</p>



SOP-WFM-09
BUCKET AND STOPWATCH
METHOD FOR MEASURING
FLOW

AUTHORIZED
VERSION:
10/13/2020
PAGE 3 of 7

2. Place collection container directly under the discharge.	Place collection container (e.g., 1-liter beaker) directly under the discharge. All discharge should flow into the collection container. Note: measurement lines on the container may need to be measured and clearly marked ahead of time.
3. Time discharge with stopwatch.	Time discharge with stopwatch for 1 minute. Record volume in logbook.
4. Repeat.	Repeat steps 2 and 3 two more times to obtain a 3-point average.
5. Calculate discharge.	Calculate discharge by following Example 2 calculation.

Example 2 Calculation: Calculating Discharge

A 1-liter beaker is placed under a discharging hose. The beaker fills to 55 milliliters, 60 milliliters, and 58 milliliters in the 1 minute.

Calculate average volume:

Add the 3 recorded volumes together and divide by 3 to obtain the average volume.

$$\text{Average volume} = \frac{55 + 60 + 58}{3} = 57.7 \text{ mL}$$

Convert average volume in milliliters to liters:

Divide average volume by 100 milliliters per liter to obtain liters.

$$\text{Average volume} = \frac{57.7 \text{ milliliters}}{100 \text{ milliliters/liter}} = 0.58 \text{ liters}$$

Calculate the discharge:

Divide the average volume of the beaker (liters) by the time (minute).

$$\text{Discharge} = \frac{0.58 \text{ liters}}{1 \text{ minute}} = 0.58 \text{ liters per minute}$$

Source: Estimating Discharge and Stream Flows A Guide for Sand and Gravel Operators, July 2005. Prepared by: Joy P. Michaud and Marlies Wierenga, EnviroVision. Ecology Publication Number 05-10-070.



SOP-WFM-09
BUCKET AND STOPWATCH
METHOD FOR MEASURING
FLOW

AUTHORIZED
VERSION:
 10/13/2020
 PAGE 4 of 7

HEALTH SAFETY SECURITY ENVIRONMENT (HSSE) CONSIDERATIONS

This section to be completed with concurrence from the Safety and Health Manager.

<i>SOURCE</i>	<i>HAZARDS</i>	<i>WHERE</i>	<i>HOW, WHEN, RESULT</i>	<i>CONTROLS</i>
CHEMICAL	Potential contact with contaminated water.	Measurement sites.	Inadvertent exposure to contaminated water could lead to adverse health effects.	Personnel will practice proper personal hygiene – wash hands prior to eating/drinking and when leaving the site. Personnel will wear nitrile gloves and safety glasses when taking measurements.
NOISE	Not applicable.			
ELECTRICAL	Not applicable.			
BODY MECHANICS	Improper lifting. Bending, squatting, and kneeling.	Measurement sites. During flow measurements.	Back injuries and muscle/back strains could result when using improper techniques to lift and carry tools and equipment. Bending, squatting, and kneeling during flow measurement could result in muscle/back strains or other injuries.	Personnel will use proper lifting techniques – get a good grip, keep the load close to the body, lift with legs and not with back, and avoid lifting loads above shoulder’s height. Two workers will lift/carry objects, if necessary. Personnel should stretch prior to starting work and take breaks when necessary.
GRAVITY	Falls from slips and trips.	Uneven terrain, slick/muddy/wet surfaces and steep slopes.	Walking/working on slick/muddy/wet and uneven terrain could cause slips and trips resulting in falls and injuries.	Personnel will wear work boots with good traction and ankle support. Personnel will be aware of working/walking surfaces and choose a path to avoid hazards. Keep work areas as dry as possible. Wear muck boots, as necessary.



**SOP-WFM-09
 BUCKET AND STOPWATCH
 METHOD FOR MEASURING
 FLOW**

**AUTHORIZED
 VERSION:**
 10/13/2020
 PAGE 5 of 7

HEALTH SAFETY SECURITY ENVIRONMENT (HSSE) CONSIDERATIONS

This section to be completed with concurrence from the Safety and Health Manager.

SOURCE	HAZARDS	WHERE	HOW, WHEN, RESULT	CONTROLS
WEATHER	Cold/heat stress.	Sites.	Exposure to cold climates may result in cold burns, frostbites, and hypothermia. Exposure to high temperatures may result in heat cramps, heat exhaustion, or heat stroke.	Training on signs and symptoms of cold/heat stress is required. Personnel will wear appropriate clothing when working outdoors. Personnel will remain hydrated and will have sufficient caloric intakes during the day. Personnel will follow procedures outlined in applicable SSHASP and/or Pioneer corporate HASP.
	Lightning.	Outdoor sites.	Electrocution, injury, death, or equipment damage could be caused by lightning strike.	Personnel will follow the 30/30 rule during lightning storms.
RADIATION	Ultraviolet (UV) radiation.	Outdoors.	Personnel could be exposed to UV radiation during summer months causing sun burns, skin damage, and eye damage.	Personnel will wear safety glasses with tinted lenses, long-sleeve work shirts, and long pants. Personnel should wear sunscreen, if necessary.
BIOLOGICAL	Plants, insects, and animals.	Sites.	Exposure to plants, insects, and/or animals may cause rashes, blisters, redness, and swelling.	Training on the signs and symptoms of exposure to plants, insects, and animals is required. Avoid contact with plants, insects, and animals. First-aid kits will be available on site. Personnel with allergies will notify their supervisor.
MECHANICAL	Pinch points and cuts.	When discharge occurs via a channel and a temporary dam is needed.	Hand injuries could occur when handling material (e.g., rocks, dirt, pipe) to build a dam, if needed.	If building a dam is necessary, personnel will wear leather gloves.



**SOP-WFM-09
 BUCKET AND STOPWATCH
 METHOD FOR MEASURING
 FLOW**

**AUTHORIZED
 VERSION:**
 10/13/2020
 PAGE 6 of 7

HEALTH SAFETY SECURITY ENVIRONMENT (HSSE) CONSIDERATIONS

This section to be completed with concurrence from the Safety and Health Manager.

<i>SOURCE</i>	<i>HAZARDS</i>	<i>WHERE</i>	<i>HOW, WHEN, RESULT</i>	<i>CONTROLS</i>
PRESSURE	Not applicable.			
THERMAL	Not applicable.			
HUMAN FACTORS	Inexperienced and improperly trained personnel.	Sites.	Inexperienced personnel and improper training could cause incidents resulting in adverse health effects and/or property damage.	Personnel will be properly trained in this procedure and other applicable procedures. Personnel will implement stop work procedures, if necessary.
SIMOPS (Simultaneous Operations)	Not applicable.			

ADDITIONAL HSSE CONSIDERATIONS

This section to be completed with concurrence from the Safety and Health Manager.



REQUIRED PPE	Personal Protection Equipment (PPE): Hard hat, safety glasses, high-visibility work shirt or vest, long pants, work boots, nitrile gloves, and leather gloves.
APPLICABLE SDSs	Safety Data Sheets (SDSs) will be maintained based on site characterization and contaminants. Safety Data Sheets are available to Pioneer personnel at the link below: https://pioneertechnicalservices.sharepoint.com/Safety/SafetyDataSheets
REQUIRED PERMITS/ FORMS	Per site/project requirements.
ADDITIONAL TRAINING	Per site/project requirements.



SOP-WFM-09
BUCKET AND STOPWATCH
METHOD FOR MEASURING
FLOW

AUTHORIZED
VERSION:
 10/13/2020
 PAGE 7 of 7

DRAWINGS, DOCUMENTS, AND TOOLS/EQUIPMENT	
The following documents should be referenced to assist in completing the associated task.	
DRAWINGS	Map with site location and sample locations.
RELATED SOPs/ PROCEDURES/ WORK PLANS	
TOOLS/ EQUIPMENT	A variety of different sized containers based on expected flow, beakers up to 1 liter, buckets up to 5 gallons (with volume marked), stopwatch, logbook, and pen.
FORMS/ CHECKLIST	

APPROVALS/CONCURRENCE	
By signing this document, all parties acknowledge the completeness and applicability of this SOP for its intended purpose. Also, by signing this document, it serves as acknowledgement that I have received training on the procedure and associated competency testing.	
SOP TECHNICAL AUTHOR	DATE
 Julie Flammang	10/13/2020
SAFETY AND HEALTH MANAGER	DATE
 Tara Schleeman	10/13/2020



**SOP-GEOPROBE-01;
MOBILIZATION AND LOADING/
UNLOADING THE GEOPROBE®**

STATUS: DRAFT
DATE ISSUED:
11/16/2020
REVISION: 1
PAGE 1 of 9

PURPOSE	To provide standard instructions for mobilizing and loading/unloading the Geoprobe® Model 7822DT.
SCOPE	This practice has been prepared for the Pioneer Technical Services, Inc. (Pioneer) workforce and applies to work carried out by and on behalf of Pioneer. All members of the Pioneer workforce who conduct the work shall be trained and competent in the risk-assessed work described below.

WORK INSTRUCTIONS

The following instructions are intended to provide sufficient guidance to perform the task in a safe, accurate, and reliable manner. Should these instructions present information that is inaccurate or unsafe, operations personnel must bring the issue to the attention of the Project Manager and the appropriate revisions made. All work carried under this SOP will be consistent with procedures and policies described in the appropriate Operation, Maintenance, and Monitoring (O&M) Plan (where applicable), appropriate Site-Specific Health and Safety Plan (SSHASP), and Pioneer Corporate Health and Safety Plan (HASP).

TASK	INSTRUCTIONS
Trailer hook-up	<ol style="list-style-type: none"> 1. Turn on the diesel work truck to allow the glow plugs to warm up. To warm the glow plugs, turn the ignition switch to the first setting on the truck and there will be a light on the dashboard that looks like a pig tail. When this light goes off, the glow plugs are warmed, and the truck can be started. 2. Before backing up the truck, ensure that the gooseneck is high enough that it won't hit the truck when backing up. Using a spotter, back the truck up so the ball on the truck's hitch is right below the coupler on the trailer hitch. 3. When the ball of the truck's hitch is located under the coupler on the trailer, ensure that the coupler is unlatched. To do this, make sure the pin, which is normally locked in the down position is raised up and flipped over into the catch and you will see it has locked in the up position. 4. Turn the front trailer jack's crank counterclockwise to lower trailer onto the truck's hitch . 5. To make sure coupler is latched securely to ball, swing pin out of the catch and let it drop straight down through the hole in the plate and then swing it to the side. 6. When the trailer is locked to the truck's hitch, pull the clip and safety pin from the front jack's foot plate and move the spring-loaded foot plate up into the jack and replace the safety pin and clip. 7. Attach the trailer's safety chains and break away system to the truck's hitch system. 8. Inspect and attach the trailer's brake and trailer's lights cord to the power output connection on the truck. Verify that the trailer's lighting and braking system are



**SOP-GEOPROBE-01;
MOBILIZATION AND LOADING/
UNLOADING THE GEOPROBE®**

STATUS: DRAFT
DATE ISSUED:
11/16/2020
REVISION: 1
PAGE 2 of 9

	<p>working.</p> <p>9. Ensure that the trailer’s doors are all locked during transport.</p> <p>10. Verify that all jacks (two on the front of the trailer) are up off the ground and secured. Also verify that the safety chains, pins, and power cord are attached and secured.</p> <p>11. Remove the chocks out from under the trailer’s tires and place them in the back of the truck.</p> <p>The Geoprobe® trailer is now ready for mobilization to and from job sites.</p>
<p>Unloading the Geoprobe®</p>	<ol style="list-style-type: none"> 1. Park the trailer on level ground. Set the parking brake on the truck and place tire chocks under the front and rear of one set of trailer’s tires. Verify that the trailer’s hitch is securely fastened to the truck. 2. Remove the safety pin and then pull down the spring assisted ramps. 3. Take the front and back ratchet straps off of the Geoprobe®. 4. Start the Geoprobe® and allow its fluids sufficient time to warmup to prevent unnecessary wear on the engine and hydraulic systems. While the Geoprobe® is going through the warmup, the system will lock out the Geoprobe® so that it can’t be moved until the warmup is completed. 5. Prior to backing out of the trailer, ensure the blade and/or toolbox are raised so that they do not drag or get caught on anything during the unloading process. Slowly back the Geoprobe® out of the trailer using the remote control. For proper alignment, split the middle of the two tracks when unloading the Geoprobe®. Use the slow speed on the remote control when unloading the Geoprobe® from the trailer. <p>Note: when the Geoprobe’s center of gravity is at the end of the trailer, the front portion of the tracks will lift off the trailer’s floor and the back portion of the tracks will lower onto the ramps, however the operator is controlling the Geoprobe® from the remote control and is not operating the Geoprobe® from a driver’s seat on the machine.</p> <ol style="list-style-type: none"> 6. Back the Geoprobe® 4 to 5 feet off the ramp and perform the pre-job inspection. Refer to SOP-GEOPROBE-02 Pre-Job and Post-Job Inspection for this procedure.
<p>Loading the Geoprobe®</p>	<ol style="list-style-type: none"> 1. Perform the post-job inspection per SOP-GEOPROBE-02 Pre-job and Post-job Inspection as necessary. 2. Connect the truck to the trailer and park the trailer on level ground. Set the truck’s parking brake and place tire chocks under the front and rear of one set of trailer’s tires.



**SOP-GEOPROBE-01;
MOBILIZATION AND LOADING/
UNLOADING THE GEOPROBE®**

STATUS: DRAFT
DATE ISSUED:
11/16/2020
REVISION: 1
PAGE 3 of 9

	<p>3. Remove the safety pin and then pull down the spring assisted ramps.</p> <p>4. Cool down of the Geoprobe® may be necessary before loading into the trailer. There are two fans that are used to cool the machine and will be visible on the control panel if they are turned on. If either fan is operating, do not turn off the Geoprobe®. The fans will turn off automatically when the Geoprobe® reaches the necessary cool down temperature.</p> <p>5. Slowly move the Geoprobe® forward into the trailer using the remote control. For proper alignment, split the middle of the two tracks when loading the Geoprobe®. Ensure the Geoprobe® blade is up as high as it can go so the job box does not drag or get caught during the loading process. Use the slow speed on the remote control when loading the Geoprobe® into the trailer.</p> <p>6. Flip the spring assisted Ramps back up and put the safety pin back in place.</p> <p>Loading the Geoprobe® is complete.</p>
<p>Securing the Geoprobe® in the trailer</p>	<p>1. Ensure the Geoprobe® is centered in the trailer. Refer to SOP-GEOPROBE-04 Driving the Geoprobe® Model 7822DT for driving procedures.</p> <p>2. Make sure the Geoprobe® tracks are 3-4 inches in front of where the black strips start on the trailer floor. This will put the Geoprobe® in an optimal position for weight distribution on the trailer axles and tongue.</p> <p>3. Attach the two front ratchet straps to the front strap connection on the Geoprobe® and the front strap rings located on the floor towards the front of the trailer. Tighten the ratchet strap so there is no slack in the strap.</p> <p>4. Attach the two ratchet straps to the back-strap rings located at the rear of the trailer. Tighten the strap so there is no slack in the strap.</p>



**SOP-GEOPROBE-01;
MOBILIZATION AND LOADING/
UNLOADING THE GEOPROBE®**

STATUS: DRAFT
DATE ISSUED:
11/16/2020
REVISION: 1
PAGE 4 of 9

HSSE CONSIDERATIONS

This section to be completed with concurrence from the Safety and Health Manager.

<i>SOURCE</i>	<i>HAZARDS</i>	<i>WHERE</i>	<i>HOW, WHEN, RESULT</i>	<i>CONTROLS</i>
CHEMICAL	Hydraulic fluid and diesel.	Geoprobe®.	Employees could be exposed to hydraulic fluid and/or diesel via inhalation, ingestion and skin/eye contact, when operating the Geoprobe®, or if equipment malfunctions resulting in adverse health effects.	Employees will wear work gloves and safety glasses, if contact with hydraulic fluid/diesel is possible. In the event of a spill/leak, personnel will contain the fluid using the spill cleanup material available in the Geoprobe's trailer. Cleanup materials will be disposed of according to state's regulations. All components of the Geoprobe® will be inspected prior to and at the completion of the task. Non-essential personnel will maintain a 20-foot buffer zone around the equipment.
NOISE	Elevated noise levels.	Geoprobe®.	Employees could be exposed to elevated noise levels when driving the Geoprobe® resulting in irritability, decreased concentration, and noise-induced hearing loss.	Personnel within a 20-foot buffer of the Geoprobe® will wear single hearing protection (e.g., ear muffs). Non-essential personnel will maintain a 20-foot buffer zone around the Geoprobe®.
ELECTRICAL	Defective electrical lines.	Geoprobe®.	Contact with defective electrical lines could result in personal injury.	Inspect electrical lines of the Geoprobe® prior to and at the completion of the task.
BODY MECHANICS	Not Applicable			



**SOP-GEOPROBE-01;
MOBILIZATION AND LOADING/
UNLOADING THE GEOPROBE®**

STATUS: DRAFT
DATE ISSUED:
11/16/2020
REVISION: 1
PAGE 6 of 9

			summer months causing sun burns, skin damage, and eye damage.	pants. Employees should wear sunscreen, if necessary.
BIOLOGICAL	Plants, insects, and animals.	Sites.	Exposure to plants, insects, and/or animals may cause rashes, blisters, redness, and swelling.	Training on the signs and symptoms of exposure to plants, insects, and animals is required. Avoid contact with plants, insects, and animals. First-aid kits will be available on site. Employees with allergies should notify their supervisor.
MECHANICAL	Backing up the work truck.	Sites.	Incidents could occur when backing up the work truck to connect the trailer to the truck resulting in personal injury and/or property damage.	Use a spotter when backing up the work truck. If a spotter is not available, walk around the truck to check distances and look for obstacles that may be in your blind spots. The spotter will wear high visibility clothing.
	Unloading the Geoprobe®.	Sites.	Incidents could occur when backing up the Geoprobe® to unload it from the trailer resulting in personal injury and/or property damage.	As a precaution, the operator should be ready to move the track control levers forward to stop the reverse motion. The operator will use the slow speed on the remote control when backing up the Geoprobe®.
	Towing the Geoprobe's trailer.	Road.	Incidents could occur when towing the Geoprobe's trailer to and from the job site resulting in personal injury and/or property damage.	Driver will follow defensive driving techniques and will be trained on how to tow a trailer. Driver will verify that the trailer's safety chains are attached to the truck's hitch system.



**SOP-GEOPROBE-01;
MOBILIZATION AND LOADING/
UNLOADING THE GEOPROBE®**

STATUS: DRAFT
DATE ISSUED:
11/16/2020
REVISION: 1
PAGE 8 of 9

HUMAN FACTORS	Inexperienced and improperly trained worker.	Sites.	Inexperience workers and improper training could cause incidents resulting in personal injuries and/or property damage.	Employees will be properly trained in this procedure and other applicable procedures. When loading/unloading for the first time, an experienced operator should be on site to help coach the loading/unloading process. All employees operating the Geoprobe® will be familiar with the basic controls of the machine including the Emergency Kill switch button. Employees will implement stop work procedures, if necessary.
SIMOPS	Not applicable.			

ADDITIONAL HSSE CONSIDERATIONS

This section to be completed with concurrence from the Safety and Health Manager.

REQUIRED PPE	Level D PPE (hard hat, safety glasses, high-visibility work shirt or vest, long pants, steel-toed boots), work gloves, and single hearing protection (e.g., ear muffs).
APPLICABLE SDS	SDSs will be maintained based on-site characterization and contaminants. Hydraulic Fluid and diesel.
REQUIRED PERMITS/FORMS	Per site/project requirements.
ADDITIONAL TRAINING	Per site/project requirements.

DRAWINGS, DOCUMENTS, AND TOOLS/EQUIPMENT

The following documents should be referenced to assist in completing the associated task.

P&IDS	
DRAWINGS	
RELATED SOPs/PROCEDURES/ WORK PLANS	SOP-GEOPROBE-02 Pre-Job and Post-Job Inspection SOP-GEOPROBE-03 Starting and Stopping the Kubota Engine SOP-GEOPROBE-04 Driving the Geoprobe® Model 7822DT
TOOLS	
FORMS/CHECKLIST	



**SOP-GEOPROBE-01;
MOBILIZATION AND LOADING/
UNLOADING THE GEOPROBE®**

STATUS: DRAFT
DATE ISSUED:
11/16/2020
REVISION: 1
PAGE 9 of 9

APPROVALS/CONCURRENCE

By signing this document, all parties acknowledge the completeness and applicability of this SOP for its intended purpose. Also, by signing this document, it serves as acknowledgement that I have received training on the procedure and associated competency testing.

SOP TECHNICAL AUTHOR	DATE
SAFETY AND HEALTH MANAGER	DATE

Revisions:

Revision	Description	Date
1	Updates to SOP to reflect Geoprobe ® Model 7822DT	11/16/2020



**SOP-GEOPROBE-02;
PRE AND POST JOB INSPECTION**

STATUS: DRAFT
DATE ISSUED:
11/16/2020
REVISION: 1
PAGE 1 of 9

PURPOSE	To provide standard instructions for conducting a pre-job and post-job Geoprobe [®] inspection.
SCOPE	This practice has been prepared for the Pioneer Technical Services, Inc. (Pioneer) workforce and applies to work carried out by and on behalf of Pioneer. All members of the Pioneer workforce who conduct the work shall be trained and competent in the risk-assessed work described below.

WORK INSTRUCTIONS

The following instructions are intended to provide sufficient guidance to perform the task in a safe, accurate, and reliable manner. Should these instructions present information that is inaccurate or unsafe, operations personnel must bring the issue to the attention of the Project Manager and the appropriate revisions made. All work carried under this SOP will be consistent with procedures and policies described in the appropriate Operation, Maintenance, and Monitoring (O&M) Plan (where applicable), appropriate Site-Specific Health and Safety Plan (SSHASP), and Pioneer Corporate Health and Safety Plan (HASP).

TASK	INSTRUCTIONS
Pre-job Geoprobe [®] setup.	<p>Note: this procedure assumes that the Geoprobe[®] is out of the trailer. Refer to SOP-GEOPROBE-01 Mobilization and Loading/Unloading the Geoprobe[®] for instructions on how to back the Geoprobe[®] out of the trailer. The pre- and post-job inspections cannot be fully performed while the Geoprobe[®] is in the trailer due to the mast being folded over and preventing the removal of the engine cover lid.</p> <ol style="list-style-type: none"> 1. Place the Geoprobe[®] on flat ground. 2. Unfold the derrick by pushing the fold lever downward. Unfold the derrick until the foot of the Geoprobe[®] is parallel to the ground. 3. Lower the foot of the Geoprobe[®] until it touches the ground by pushing the foot lever downward. 4. Turn off the Geoprobe[®].
Pre-job engine hours.	<ol style="list-style-type: none"> 1. Locate the run time odometer on the control panel and write down the machine's current hours on the Geoprobe's pre-operation inspection sheet. A Geoprobe's pre-operation inspection form is attached to this SOP as an example.
Pre-job engine compartment inspection.	<ol style="list-style-type: none"> 1. Open the engine compartment by removing the rear upper engine cover. 2. Check the engine oil level using the oil dip stick. The oil level should be between the marks on the dip stick. If the oil level is below the lowest mark, additional engine oil is required for engine protection. 3. Check the engine's coolant fluid level inside the radiator by checking where the fluid is in relation to the "Full" and "Low" line on the reservoir.



**SOP-GEOPROBE-02;
PRE AND POST JOB INSPECTION**

STATUS: DRAFT
DATE ISSUED:
 11/16/2020
REVISION: 1
PAGE 2 of 9

	<ol style="list-style-type: none"> 4. Check the hydraulic fluid level by reading the sight glass located On the control panel. Maintain the hydraulic fluid at or within 0.5 inches below the upper solid black line on the glass. If the hydraulic fluid level is below, new hydraulic oil must be added to the hydraulic oil tank until the fluid rises to the upper mark on the site glass. 5. Check diesel fuel level by removing the fuel cap and visually inspecting fuel level or by turning ignition switch to energize fuel gage on the control panel. 6. Ensure the hydraulic fluid cap, fuel cap, and radiator cap are all in place. 7. Check the radiator for leaks, cracks, and cleanliness. Inspect radiator’s hoses and radiator’s body for coolant leaks and inspect the engine’s compartment for signs of coolant leakage. 8. Inspect the engine belts for cracking and glazing, indicators that the belts are worn and will need replacement. Also, check the belts for tension by pushing on the longest length of belt to determine the amount deflection. If the deflection is greater than 0.5 inches, the belt tension will require adjustment. 9. Document fluid levels and other notable conditions on the pre-operation inspection sheet. 10. Close the engine compartment.
<p>Pre-job machine chassis inspection.</p>	<ol style="list-style-type: none"> 1. Inspect the rubber tracks for cracks and nicks, indicating that the tracks will need to be replaced soon. Also, check for proper tension by raising the tracks off the ground. The tracks should have 3 inches of slack in them at the midpoint of the track. 2. Grease three Zirk fittings on Geoprobe® as required. A single Zirk fitting is located under the rig in the rotation bearing. The bearing requires 5 pumps of multipurpose grease every 100 hours of operation. To gain access to the grease fitting, first make sure the engine is off and the ignition key is removed. Slide in between the tracks from under the front of the vehicle. Two additional Zirk fittings are located on the fold bracket pivot points. These fittings require 3 pumps of grease every 50 hours of operation. 3. Visually check the hydraulic cylinders for leaks. The hydraulic cylinders will require little to no maintenance. Under normal use, hydraulic cylinder rods will have some fluid accumulation. Excessive leaks between the cylinder rod and cylinder rod seal indicates that service is necessary by Geoprobe® Systems or a qualified hydraulic cylinder



**SOP-GEOPROBE-02;
PRE AND POST JOB INSPECTION**

STATUS: DRAFT
DATE ISSUED:
 11/16/2020
REVISION: 1
PAGE 3 of 9

	<p>service.</p> <ol style="list-style-type: none"> 4. Locate the battery and fuse/relay box by opening the side door behind the pipe rack. Check the battery and fuse/relay box. Ensure they are clean and free of corrosion. 5. Visually check the hydraulic hoses and fittings for leaks. Operator should look for hydraulic hoses that are leaking, cut, collapsed, or bulged. <p>Note: if hydraulic fittings are loose, tighten them. If hoses are leaking or fittings cannot be tightened, immediately stop work, and have the given fittings and/or hoses replaced.</p> <ol style="list-style-type: none"> 6. Check the Geoprobe's frame for cracks or damage. 7. Ensure the rear-tool basket (if used) is attached to rear blade of the Geoprobe®. 8. Ensure the fire extinguisher is inspected and located in the basket or with the Geoprobe® at all times during Geoprobng activities. 9. Ensure the five emergency stop buttons are functioning properly. Test each button individually by starting the Geoprobe® and pushing that individual emergency stop button. If the engine quits, that emergency stop button is working. If the emergency stop buttons are not working, field work will be halted until the stop buttons are repaired and functioning properly. 10. Inspect Geoprobe's assembly bolts and look for loose screws and nuts. The hammering operations tend to loosen fasteners over time making it important to visually check chassis screws, nuts, and bolts. Tighten any loose fasteners that are identified. 11. Check the hose carriers/housings for breaks in brackets.
<p>Pre-job control panel and accessories inspection.</p>	<ol style="list-style-type: none"> 1. Ensure all gauges are operating properly by examining each gauge to see if the measurement is normal or the dial indicator is moving. 2. Ensure all control levers are in the neutral position and are secure. 3. Ensure all control switches are operating properly by testing each switch to determine if function control is maintained. 4. Visually inspect the winch line and winch safety hook for any damage or fraying. 5. If the drop hammer is being used make sure it is secured. Check the



**SOP-GEOPROBE-02;
PRE AND POST JOB INSPECTION**

**STATUS: DRAFT
DATE ISSUED:
11/16/2020
REVISION: 1
PAGE 4 of 9**

	<p>hoses coming from the drop hammer to ensure there are no leaks and also make sure the auxiliary hydraulic line and fittings are free of leaks. Refer to SOP-GEOPROBE-09 DH133 Drop Hammer to see the drop hammer securing procedures.</p>
<p>Post-job Geoprobe[®] inspection.</p>	<ol style="list-style-type: none"> 1. Move Geoprobe to a flat, safe location. 2. With the engine running and cooling down, perform a visual inspection of the Geoprobe[®], looking for leaking oil, coolant, or hydraulic fluid. Additionally, look for loose bolts, nuts, and screws that may have come loose during the day's operation. This inspection will identify any new issues with the Geoprobe[®] that could be repaired or replaced before the next work day. <p>Note: a thorough inspection is not usually performed at the end of the day when the Geoprobe[®] components are hot. Checking fluid levels in a hot engine is hazardous, especially coolant levels.</p>



**SOP-GEOPROBE-02;
PRE AND POST JOB INSPECTION**

**STATUS: DRAFT
DATE ISSUED:
11/16/2020
REVISION: 1
PAGE 5 of 9**

HSSE CONSIDERATIONS

This section to be completed with concurrence from the Safety and Health Manager.

<i>SOURCE</i>	<i>HAZARDS</i>	<i>WHERE</i>	<i>HOW, WHEN, RESULT</i>	<i>CONTROLS</i>
CHEMICAL	Diesel, Oil, hydraulic fluid, coolant, and fitting grease.	Geoprobe®.	Employees could be exposed to diesel, hydraulic fluid, coolant, and/or fitting grease via inhalation, ingestion, and skin/eye contact, when inspecting the Geoprobe®, or if equipment malfunctions resulting in adverse health effects.	Employees will wear work gloves and safety glasses, if contact with diesel, oil, hydraulic fluid, coolant or fitting grease is possible. In the event of a spill/leak, personnel will contain the fluid using the spill cleanup material available in the Geoprobe's trailer. Cleanup materials will be disposed of according to state's regulations. All components of the Geoprobe® will be inspected prior to and at the completion of the task. Non-essential personnel will maintain a 20-foot buffer zone around the equipment.
NOISE	Elevated noise levels.	Geoprobe®.	Employees could be exposed to elevated noise levels when the Geoprobe® is running resulting in irritability, decreased concentration, and noise-induced hearing loss.	Personnel within a 20-foot buffer of the Geoprobe® will wear single hearing protection (e.g., earmuffs). Non-essential personnel will maintain a 20-foot buffer zone around the Geoprobe®.
ELECTRICAL	Defective electrical lines.	Geoprobe®.	Contact with defective electrical lines could result in personal injury.	Inspect electrical lines of the Geoprobe® prior to and at the completion of the task. Do not operate the Geoprobe® if defective electrical lines are found during the pre/post job inspection.
BODY MECHANICS	Not applicable.			
GRAVITY	Falls from slips and trips.	Uneven terrain, slick/muddy/wet	Walking on slick/muddy/wet	Workers will wear work boots with good traction and ankle



**SOP-GEOPROBE-02;
PRE AND POST JOB INSPECTION**

**STATUS: DRAFT
DATE ISSUED:
11/16/2020
REVISION: 1
PAGE 6 of 9**

HSSE CONSIDERATIONS

This section to be completed with concurrence from the Safety and Health Manager.

		surfaces and steep slopes.	and uneven terrain could cause slips and trips resulting in falls and injuries.	support. Employees will plan their path and walk cautiously. Keep work area free of tools/rods. If conditions are wet/muddy, muck boots may be worn.
WEATHER	Cold/heat stress.	Outdoors.	Exposure to cold climates may result in cold burns, frostbites, and hypothermia. Exposure to high temperatures may result in heat cramps, heat exhaustion, or heat stroke. Electrocution, injury, death, or equipment damage could be caused by lightning strike.	Training on signs and symptoms of cold/heat stress is required. Personnel will wear appropriate clothing when working outdoors (e.g. layers). Employees will remain hydrated and will have sufficient caloric intake during the day. Personnel will follow procedures outlined in applicable SSHASP and/or Pioneer corporate HASP. Employees will follow the 30/30 rule during lighting storms.
RADIATION	Ultraviolet (UV) radiation.	Outdoors.	Employees could be exposed to UV radiation during summer months causing sun burns, skin damage, and eye damage.	Employees will wear safety glasses with tinted lenses, long-sleeve work shirts, and long pants. Employees should wear sunscreen, if necessary.
BIOLOGICAL	Plants, animals, and insects.	Sites.	Exposure to plants, insects, and/or animals may cause rashes, blisters, redness, and swelling.	Training on the signs and symptoms of exposure to plants, insects, and animals is required. Avoid contact with plants, insects, and animals. First-aid kits will be available in work trucks. Employees with allergies should notify their supervisor.
MECHANICAL	Pinch Points from folding and	Geoprobe®	Employees could be exposed to	Personnel will wear work gloves and will watch for hand



**SOP-GEOPROBE-02;
PRE AND POST JOB INSPECTION**

**STATUS: DRAFT
DATE ISSUED:
11/16/2020
REVISION: 1
PAGE 7 of 9**

HSSE CONSIDERATIONS

This section to be completed with concurrence from the Safety and Health Manager.

	unfolding the Geoprobe.		hand injuries, such as lacerations, punctures, cuts, and pinched fingers, when folding and unfolding the Geoprobe® during pre/post job inspection.	placement when performing these tasks. All non-essential personnel will maintain a 20-foot buffer zone around the Geoprobe®.
PRESSURE	Pressurized hydraulic lines.	Geoprobe®.	Faulty pressurized hydraulic lines could burst resulting in injury/ exposure and hydraulic fluid release.	All components of the Geoprobe® will be inspected prior to and at the completion of the task. In the event of a spill/leak, personnel will contain the fluid using the spill cleanup material available in the Geoprobe's trailer. Cleanup materials will be disposed of according to state's regulations. Non-essential personnel will maintain a 20-foot buffer zone around the equipment.
THERMAL	Hot fluids in the engine compartment.	Geoprobe®.	Employees could be exposed to hot fluids in the engine compartment that if contact occurs could result in injury/exposure or fluid release.	All components of the Geoprobe® will be inspected prior to and at the completion of the task. Allow time for the engine and fluids to cool prior to performing the pre/post job inspection. In the event of a spill/leak, personnel will contain the fluid using the spill cleanup material available in the Geoprobe's trailer. Cleanup materials will be disposed of according to state's regulations. Employees will use Level D PPE and proper gloves when performing pre/post job inspections. Non-essential personnel will maintain a 20-foot buffer zone around the equipment.



**SOP-GEOPROBE-02;
PRE AND POST JOB INSPECTION**

STATUS: DRAFT
DATE ISSUED:
11/16/2020
REVISION: 1
PAGE 8 of 9

HSSE CONSIDERATIONS
This section to be completed with concurrence from the Safety and Health Manager.

HUMAN FACTORS	Inexperienced and improperly trained worker.	Sites.	Inexperienced workers and improper training could cause incidents resulting in personal injuries and/or property damage.	Employees will be properly trained in this procedure and other applicable procedures. When performing the pre/post job inspection for the first time, an experienced operator should be on site to help coach the pre/post job inspection process. All employees operating the Geoprobe® will be familiar with the basic controls of the machine including the Emergency kill switch button. Employees will implement stop work procedures, if necessary.
SIMOPS	Not applicable.			

ADDITIONAL HSSE CONSIDERATIONS
This section to be completed with concurrence from the Safety and Health Manager.

REQUIRED PPE	Level D PPE (hard hat, safety glasses, high-visibility work shirt or vest, long pants, steel-toed boots), work gloves, and single hearing protection (e.g., earmuffs).
APPLICABLE SDS	SDSs will be maintained based on-site characterization and contaminants.
REQUIRED PERMITS/FORMS	Per site/project requirements.
ADDITIONAL TRAINING	Per site/project requirements.

DRAWINGS, DOCUMENTS, AND TOOLS/EQUIPMENT
The following documents should be referenced to assist in completing the associated task.

P&IDS	
DRAWINGS	
RELATED SOPs/PROCEDURES/	SOP-GEOPROBE-01 Mobilization and Loading/Unloading the Geoprobe® SOP-GEOPROBE-09 DH133 Drop Hammer



**SOP-GEOPROBE-02;
PRE AND POST JOB INSPECTION**

STATUS: DRAFT
DATE ISSUED:
 11/16/2020
REVISION: 1
PAGE 9 of 9

WORK PLANS	
TOOLS	
FORMS/CHECKLIST	

APPROVALS/CONCURRENCE	
<p>By signing this document, all parties acknowledge the completeness and applicability of this SOP for its intended purpose. Also, by signing this document, it serves as acknowledgement that I have received training on the procedure and associated competency testing.</p>	
SOP TECHNICAL AUTHOR	DATE
SAFETY AND HEALTH MANAGER	DATE

Revisions:

Revision	Description	Date
1	Updates to SOP to reflect Geoprobe ® Model 7822 DT	11/16/2020



**SOP-GEOPROBE-03;
STARTING AND STOPPING
THE KUBOTA ENGINE**

**STATUS: DRAFT
DATE ISSUED:
11/16/2020
REVISION: 1
PAGE 1 of 6**

PURPOSE	To provide standard instructions for starting and stopping the Kubota Diesel Engine on the Geoprobe®.
SCOPE	This practice has been prepared for the Pioneer Technical Services, Inc. (Pioneer) workforce and applies to work carried out by and on behalf of Pioneer. All members of the Pioneer workforce who conduct the work shall be trained and competent in the risk-assessed work described below.

WORK INSTRUCTIONS

The following instructions are intended to provide sufficient guidance to perform the task in a safe, accurate, and reliable manner. Should these instructions present information that is inaccurate or unsafe, operations personnel must bring the issue to the attention of the Project Manager and the appropriate revisions made. All work carried under this SOP will be consistent with procedures and policies described in the appropriate Operation, Maintenance, and Monitoring (O&M) Plan (where applicable), appropriate Site-Specific Health and Safety Plan (SSHASP), and Pioneer Corporate Health and Safety Plan (HASP).

TASK	INSTRUCTIONS
Preparing the Engine for Start Up	<ol style="list-style-type: none"> 1. Make sure the Geoprobe® is in an open area for ventilation. When starting the Geoprobe® in the trailer completely open the front and back doors to provide ventilation. 2. Ensure as the operator you are familiar with all five kill switches on the Geoprobe®. There is a kill switch located on the remote control, on the control panel, one on each side of the Geoprobe®, and the last kill switch is a pull latch cable located next to the control panel.
Starting the Kubota Engine.	<ol style="list-style-type: none"> 1. Warm the glow plugs before starting. To warm the glow plugs, turn the key counterclockwise. A message will appear on the control panel when the machine is ready. Note: In cold weather conditions, it is good practice to warm the glow plugs twice. Also, if the machine has been warmed up and been running, then there is no need to warm the glow plugs again before start up. 2. Turn ignition key clockwise to activate the starter motor. Release the ignition key when the engine starts and runs on its own power. IMPORTANT: Do not run the starter motor for longer than 10 seconds. If the engine does not start running, then allow 30 seconds to pass and repeat the starting procedure. 3. Verify the oil pressure gauge is reading in the white on the pressure gauge and the battery gauge is also reading in the white. (Refer to the Kubota Manual for troubleshooting procedures).



**SOP-GEOPROBE-03;
STARTING AND STOPPING
THE KUBOTA ENGINE**

**STATUS: DRAFT
DATE ISSUED:
11/16/2020
REVISION: 1
PAGE 2 of 6**

	<p>4. Allow the engine to run approximately 5 to 10 minutes, or through a complete warm up cycle, to bring the coolant and hydraulic fluid up to running temperature. The machine will be locked out until the warm up cycle is completed and fluids are at correct operating temperatures. The control panel has gauges that show hydraulic fluid temperature, hydraulic tank temperature, and coolant temperature.</p>
Running the Kubota Engine	<p>1. When the engine is running between pushing and/or sampling procedures, the machine is equipped with an automatic throttle and will lower the throttle. This will help to conserve fuel, prolong the engine life, and reduce noise levels.</p>
Stopping the Kubota Engine	<p>1. Check the control panel to see if the two fans are running. If either fan is on, the Geoprobe[®] needs to stay on to allow the fan(s) to cool the engine and fluids. Once both fans are turned off, the Geoprobe[®] is cool and can be turned off.</p> <p>2. Turn the ignition key to the “OFF” position.</p> <p>IMPORTANT: Familiarize yourself with the engine kill switches so in case of an emergency these switches can be easily used!!!</p>

HSSE CONSIDERATIONS

This section to be completed with concurrence from the Safety and Health Manager.

<i>SOURCE</i>	<i>HAZARDS</i>	<i>WHERE</i>	<i>HOW, WHEN, RESULT</i>	<i>CONTROLS</i>
CHEMICAL	Carbon Monoxide	Geoprobe [®] .	Employees could be exposed to carbon monoxide via inhalation when operating the Geoprobe [®] , resulting in adverse health effects.	Employees will make sure the Geoprobe [®] is started in an open area to provide good ventilation. If the Geoprobe [®] is started in the trailer, make sure both doors are open. Do Not work around the exhaust area (back of the rig) while the Geoprobe [®] is running. Non-essential personnel will maintain a 20-foot buffer zone around the equipment.
	Hydraulic fluid and diesel.	Geoprobe [®] .	Employees could be exposed to	Employees will wear work gloves and safety glasses, if contact with hydraulic



HSSE CONSIDERATIONS

This section to be completed with concurrence from the Safety and Health Manager.

			hydraulic fluid and or diesel via inhalation, ingestion and skin/eye contact, when operating the Geoprobe [®] , or if equipment malfunctions resulting in adverse health effects.	fluid/diesel is possible. In the event of a spill/leak, personnel will contain the fluid using the spill cleanup material available in the Geoprobe's trailer. Cleanup materials will be disposed of according to state's regulations. All components of the Geoprobe [®] will be inspected prior to and at the completion of the task. Non-essential personnel will maintain a 20-foot buffer zone around the equipment.
NOISE	Elevated noise levels.	Geoprobe [®]	Employees could be exposed to elevated noise levels when driving the Geoprobe [®] resulting in irritability, decreased concentration, and noise-induced hearing loss.	Personnel within a 20-foot buffer zone of the Geoprobe [®] will wear single hearing protection (e.g. earmuffs). Non-essential personnel will maintain a 20-foot buffer zone around the Geoprobe [®] .
ELECTRICAL	Defective electrical lines.	Geoprobe [®]	Contact with defective electrical lines could result in personal injury.	Inspect electrical lines of the Geoprobe [®] prior to and at the completion of the task.
BODY MECHANICS	Not applicable.			
GRAVITY	Falls from slips and trips.	Uneven terrain, slick, muddy/wet surfaces and steep slopes.	Walking on slick/muddy/wet and uneven terrain could cause slips and trips resulting in falls and injuries.	Workers will wear work boots with good traction and ankle support. Employees will plan their path and walk cautiously. If conditions are wet/muddy, muck boots may be worn. Keep work area free of tools/rods.



**SOP-GEOPROBE-03;
STARTING AND STOPPING
THE KUBOTA ENGINE**

**STATUS: DRAFT
DATE ISSUED:
11/16/2020
REVISION: 1
PAGE 4 of 6**

HSSE CONSIDERATIONS

This section to be completed with concurrence from the Safety and Health Manager.

WEATHER	Cold/heat stress	Outdoors.	Exposure to cold climates may result in cold burns, frostbites, and hypothermia. Exposure to high temperatures may result in heat cramps, heat exhaustion, or heat stroke.	Training on signs and symptoms of cold/heat stress is required. Personnel will wear appropriate clothing when working outdoors (e.g. layers). Employees will remain hydrated and will have sufficient caloric intakes during the day. Personnel will follow procedures outlined in applicable SSHASP and/or Pioneer corporate HASP.
	Lightning.	Sites.	Electrocution, injury, death, or equipment damage could be caused by lightning strike.	Employees will follow the 30/30 rule during lightning storms. When the Geoprobe® is running, the Geoprobe helper will watch/listen for lightning and thunder.
RADIATION	Ultraviolet (UV) radiation.	Outdoors.	Employees could be exposed to UV radiation during summer months causing sun burns, skin damage, and eye damage.	Employees will wear safety glasses with tinted lenses, long-sleeve work shirts, and long pants. Employees should wear sunscreen, if necessary.
BIOLOGICAL	Plants, Animals, Insects and Humans	Sites.	Exposure to plants, insects, and/or animals may cause rashes, blisters, redness, and swelling.	Training on the signs and symptoms of exposure to plants, insects, and animals is required. Avoid contact with plants, insects, and animals. First aid kits will be available in the work truck. Employees with allergies should notify their supervisor.
MECHANICAL	Not applicable.			
PRESSURE	Pressurized hydraulic lines.	Geoprobe®	Faulty pressurized hydraulic lines could burst	All components of the Geoprobe® will be inspected prior to and at the completion of the task. In the event of a



**SOP-GEOPROBE-03;
STARTING AND STOPPING
THE KUBOTA ENGINE**

**STATUS: DRAFT
DATE ISSUED:
11/16/2020
REVISION: 1
PAGE 5 of 6**

HSSE CONSIDERATIONS

This section to be completed with concurrence from the Safety and Health Manager.

			resulting in injury/exposure and hydraulic fluid release.	spill/leak, personnel will contain the fluid using the spill cleanup material available in the Geoprobe's trailer. Cleanup materials will be disposed of according to state's regulations. Non-essential personnel will maintain a 20-foot buffer zone around the equipment.
THERMAL	Not applicable.			
HUMAN FACTORS	Inexperience and improperly trained worker.	Sites.	Inexperience workers and improper training could cause incidents resulting in personal injuries and/or property damage.	Employees will be properly trained into his procedure and other applicable procedures. When starting/stopping for the first time, an experienced operator should be on site to help coach the process. All employees operating the Geoprobe® will be familiar with the basic controls of the machine including the Emergency kill switch button. Employees will implement stop work procedures, if necessary.
SIMOPS	Not applicable.			

ADDITIONAL HSSE CONSIDERATIONS

This section to be completed with concurrence from the Safety and Health Manager.

REQUIRED PPE	Level D PPE (hard hat, safety glasses, high-visibility work shirt or vest, long pants, steel toed boots), work gloves, and single hearing protection (e.g. earmuffs).
APPLICABLE SDS	SDSs will be maintained based on-site characterization and contaminants.
REQUIRED PERMITS/FORMS	Per site/project requirements.
ADDITIONAL TRAINING	Per site/project requirements.



**SOP-GEOPROBE-03;
STARTING AND STOPPING
THE KUBOTA ENGINE**

**STATUS: DRAFT
DATE ISSUED:
11/16/2020
REVISION: 1
PAGE 6 of 6**

DRAWINGS, DOCUMENTS, AND TOOLS/EQUIPMENT

The following documents should be referenced to assist in completing the associated task.

P&IDS	
DRAWINGS	
RELATED SOPs/PROCEDURES/ WORK PLANS	
TOOLS	
FORMS/CHECKLIST	

APPROVALS/CONCURRENCE

By signing this document, all parties acknowledge the completeness and applicability of this SOP for its intended purpose. Also, by signing this document, it serves as acknowledgement that I have received training on the procedure and associated competency testing.

SOP TECHNICAL AUTHOR	DATE
SAFETY AND HEALTH MANAGER	DATE

Revisions:

Revision	Description	Date
1	Updates to SOP to reflect Geoprobe ® Model 7822DT	11/16/2020



**SOP-GEOPROBE-04;
DRIVING AND POSITIONING THE
GEOPROBE® MODEL 7822DT**

STATUS: DRAFT
DATE ISSUED:
11/16/2020
REVISION: 1
PAGE 1 of 8

PURPOSE	To provide standard instructions for driving and positioning the Geoprobe® for probing.
SCOPE	This practice has been prepared for the Pioneer Technical Services, Inc. (Pioneer) workforce and applies to work carried out by and on behalf of Pioneer. All members of the Pioneer workforce who conduct the work shall be trained and competent in the risk-assessed work described below.

WORK INSTRUCTIONS

The following instructions are intended to provide sufficient guidance to perform the task in a safe, accurate, and reliable manner. Should these instructions present information that is inaccurate or unsafe, operations personnel must bring the issue to the attention of the Project Manager and the appropriate revisions made. All work carried under this SOP will be consistent with procedures and policies described in the appropriate Operation, Maintenance, and Monitoring (O&M) Plan (where applicable), appropriate Site-Specific Health and Safety Plan (SSHASP), and Pioneer Corporate Health and Safety Plan (HASP).

TASK	INSTRUCTIONS
Driving and Braking Controls on the Advance 7822DT	<p><i>Brakes</i> The Geoprobe® Model 7822DT is equipped with automatic track brakes. When the engine is not running the track brakes are automatically engaged.</p> <p><i>Hydraulic Steering Controls</i> The Model 7822DT has two steering control levers on the remote control. There are two additional steering control levers on the control panel but to use these levers the safety enable button must also be engaged. The two steering controls levers control two independently controlled tracks. The left lever controls the left track and the right lever controls the right track. To move forward move both control levers forward. To move in reverse move both control levers towards the back of the machine.</p> <p>There are three types of turns the Model 7822DT can accomplish. These turns are listed and described below.</p> <ol style="list-style-type: none"> 1. Gradual Turn This turn is used when the Geoprobe® is in motion. By moving the control levers in the same direction but to different degrees will produce a gradual turn. This turn is possible in both forward and reverse directions. 2. Pivot Turn This turn is used when the Geoprobe® is stationary. By moving one control lever and leaving the other control lever in neutral position will produce a pivot turn. The turn will center around the track that is stationary. This turn is used a lot when positioning the Geoprobe® over probe-hole locations. This turn is possible in both forward and reverse directions. 3. Counter-Rotation Turn This turn is used when the Geoprobe® is stationary. By moving both controls



**SOP-GEOPROBE-04;
DRIVING AND POSITIONING THE
GEOPROBE® MODEL 7822DT**

**STATUS: DRAFT
DATE ISSUED:
11/16/2020
REVISION: 1
PAGE 2 of 8**

	<p>but in opposite directions will produce a Counter-Rotation Turn. This turn will center around the center of the Geoprobe®. This turn is used widely in congested areas with limited room to turn.</p>
<p>Driving the Geoprobe® Model 7822DT</p>	<p>CAUTION: When driving the Geoprobe®, check job site for obstacles if not readily visible.</p> <ol style="list-style-type: none"> 1. Start the Geoprobe® Model 7822DT as stated in the Starting and Stopping the Kubota Engine SOP (SOP-GEOPROBE-03). 2. Make sure to do a complete walk around to make sure the blade is in the upright position and that all other rig extremities are free of debris/obstacles. 3. Make sure the Geoprobe® is in transport position. Transport position is when the rig is completely folded up. <ul style="list-style-type: none"> • The probe cylinder must be lowered all the way to the foot. To lower the foot, place the probe lever in the downward position until motion has halted. • The foot must be completely raised up to the folding bracket. To raise the foot, place the foot lever in the upward position until motion has halted. • The mast must be completely lowered to the folding bracket. To lower the mast, place the mast lever (in the downward position until motion has halted. • In order to raise the mast, the winch must be lowered. Once the mast is raised, the slack can be taken out of the winch. The opposite happens when lowering the mast, and there will be slack in the winch line. <p>NOTE: Do Not pull all the winch line in. Allow a couple inches of slack in the winch line so the line or winch does not get damaged.</p> <ul style="list-style-type: none"> • The Geoprobe® should now be completely folded up. To fold up the Geoprobe®, place the fold lever in the upward position until motion has halted. <ol style="list-style-type: none"> 4. Move the Geoprobe® to the specified location using the Track Control Levers and turns as necessary. Use best judgement on type of terrain for travel speed, generally when moving to specific location medium speed is sufficient.



**SOP-GEOPROBE-04;
DRIVING AND POSITIONING THE
GEOPROBE® MODEL 7822DT**

**STATUS: DRAFT
DATE ISSUED:
11/16/2020
REVISION: 1
PAGE 3 of 8**

	<p>5. Use a spotter when necessary to obtain the best and safest route to the probe-hole locations.</p> <p>IMPORTANT: DO NOT SIDE HILL WITH THE RIG!! When traversing through mountainous and hilly areas drive straight up or down the terrain.</p>
<p>Positioning the Geoprobe® Model 7822DT</p>	<ol style="list-style-type: none">1. After the Geoprobe® has been driven close to the new probe hole location (no farther than five feet away), unfold the derrick of the machine. To unfold the derrick, place the fold lever in the downward position until the foot of the machine is parallel to the existing ground.2. Raise the mast completely up. To raise the mast, place the mast lever in the upward position until motion is halted.3. Lower the foot until there is roughly six to twelve inches between the bottom of the foot and the existing ground. To lower the foot, place the foot lever in the downward position until the desired position is reached.4. Raise the probe cylinder three to four feet off of the foot. To raise the probe cylinder, place the probe lever in the upward position until the desired position is reached.5. Make sure the machine is extended in about half-way (six to seven and a half inches). To extend the machine in and out, place the extend lever in the upward position to move the machine in and place the extend lever in the downward position to extend out.6. Level the machine using the oscillating head and moving the foot. Use the magnetic level. <p>CAUTION: When driving the Geoprobe®, check job site for obstacles if not readily visible.</p>



**SOP-GEOPROBE-04;
DRIVING AND POSITIONING THE
GEOPROBE® MODEL 7822DT**

**STATUS: DRAFT
DATE ISSUED:
11/16/2020
REVISION: 1
PAGE 4 of 8**

HSSE CONSIDERATIONS

This section to be completed with concurrence from the Safety and Health Manager.

<i>SOURCE</i>	<i>HAZARDS</i>	<i>WHERE</i>	<i>HOW, WHEN, RESULT</i>	<i>CONTROLS</i>
CHEMICAL	Hydraulic fluid and diesel.	Geoprobe®.	Employees could be exposed to hydraulic fluid and/or diesel via inhalation, ingestion, and skin/eye contact, when operating the Geoprobe®, or if equipment malfunctions resulting in adverse health effects.	Employees will wear work gloves and safety glasses, if contact with hydraulic fluid/diesel is possible. In the event of a spill/leak, personnel will contain the fluid using the spill cleanup material available in the Geoprobe® trailer. Cleanup materials will be disposed of according to state regulations. All components of the Geoprobe® will be inspected prior to and at the completion of the task. Non-essential personnel will maintain a 20-foot buffer zone around the equipment.
NOISE	Elevated noise levels.	Geoprobe®.	Employees could be exposed to elevated noise levels when driving the Geoprobe® resulting in irritability, decreased concentration, and noise-induced hearing loss.	Personnel within a 20-foot buffer zone of the Geoprobe® will wear single hearing protection (e.g. earmuffs). Non-essential personnel will maintain a 20-foot buffer zone around the Geoprobe®.
ELECTRICAL	Defective electrical lines. Overhead Power Lines	Geoprobe®. Sites.	Contact with defective electrical lines could result in personal injury. Contact with overhead power lines could result in serious injury or property	Inspect electrical lines of the Geoprobe® prior to and at the completion of the task. Employees will maintain sufficient distance from any overhead power lines on the site. Employees will also not drive the Geoprobe® with the



**SOP-GEOPROBE-04;
DRIVING AND POSITIONING THE
GEOPROBE® MODEL 7822DT**

**STATUS: DRAFT
DATE ISSUED:
11/16/2020
REVISION: 1
PAGE 5 of 8**

HSSE CONSIDERATIONS

This section to be completed with concurrence from the Safety and Health Manager.

			damage.	mast raised.
BODY MECHANICS	Not applicable.			
GRAVITY	Not applicable.			
WEATHER	Cold/heat stress. Lightning.	Outdoors. Sites.	Exposure to cold climates may result in cold burns, frostbites, and hypothermia. Exposure to high temperatures may result in heat cramps, heat exhaustion, or heat stroke. Electrocution, injury, death, or equipment damage could be caused by lightning strike.	Training on the signs and symptoms of cold/heat stress is required. Personnel will wear appropriate clothing when working outdoors (e.g. layers). Employees will remain hydrated and will have sufficient caloric intakes during the day. Personnel will follow procedures outlines in applicable SSHASP and/or Pioneer corporate HASP. Employees will follow the 30/30 rule during lightning storms. When the Geoprobe® is running, the Geoprobe helper will watch/listen for lightning and thunder.
RADIATION	Ultraviolet (UV) radiation.	Outdoors.	Employees could be exposed to UV radiation during summer months causing sun burns, skin damage, and eye damage.	Employees will wear safety glasses with tinted lenses, long-sleeve work shirts, and long pants. Employees should wear sunscreen, if necessary.
BIOLOGICAL	Plants, animals, insects and humans.	Sites.	Exposure to plants, insects, and/or animals may cause rashes, blisters, redness, and swelling.	Training on the signs and symptoms of exposure to plants, insects, and animals is required. Avoid contact with plants, insects, and animals. First-aid kits will be available in the work trucks. Employees with allergies should notify their supervisor.
MECHANICAL	Driving on unstable ground	Sites.	Incidents could occur when	Employees will avoid side hilling in the Geoprobe® to



**SOP-GEOPROBE-04;
DRIVING AND POSITIONING THE
GEOPROBE® MODEL 7822DT**

**STATUS: DRAFT
DATE ISSUED:
11/16/2020
REVISION: 1
PAGE 6 of 8**

HSSE CONSIDERATIONS

This section to be completed with concurrence from the Safety and Health Manager.

	or sloped surfaces.		driving on unstable ground or sloped surfaces which could result in personal injury and/or property damage.	prevent tipping the machine. Employees will do a site walk around before mobilizing to the probing location to determine the best route to drive the Geoprobe®. Employees will use the remote control to move the Geoprobe®.
PRESSURE	Pressurized hydraulic lines.	Geoprobe®.	Faulty pressurized hydraulic lines could burst resulting in personal injury/exposure and hydraulic fluid release.	All components of the Geoprobe® will be inspected prior to and at the completion of the task. In the event of a spill/leak, personnel will contain the fluid using the spill cleanup material available in the Geoprobe's trailer. Cleanup materials will be disposed of according to state's regulations. Non-essential personnel will maintain a 20-foot buffer zone around the equipment.
THERMAL	Not applicable.			
HUMAN FACTORS	Inexperienced and improperly trained worker.	Sites.	Inexperience workers and improper training could cause incidents resulting in personal injuries and/or property damage.	Employees will be properly trained in this procedure and other applicable procedures. When driving the Geoprobe® for the first time, an experienced operator should be on site to help coach the driving process. All employees operating the Geoprobe® will be familiar with the basic controls of the machine including the Emergency Kill switch button. Employees will implement stop work procedures, if necessary.
SIMOPS	Not applicable.			

ADDITIONAL HSSE CONSIDERATIONS

This section to be completed with concurrence from the Safety and Health Manager.



**SOP-GEOPROBE-04;
DRIVING AND POSITIONING THE
GEOPROBE® MODEL 7822DT**

STATUS: DRAFT
DATE ISSUED:
11/16/2020
REVISION: 1
PAGE 7 of 8

HSSE CONSIDERATIONS

This section to be completed with concurrence from the Safety and Health Manager.

REQUIRED PPE	Level D PPE (hard hat, safety glasses, high-visibility work shirt or vest, long pants, steel-toed boots), work gloves, and single hearing protection (e.g. earmuffs).
APPLICABLE SDS	SDSs will be maintained based on-site characterization and contaminants.
REQUIRED PERMITS/FORMS	Per site/project requirements.
ADDITIONAL TRAINING	Per site/project requirements.

DRAWINGS, DOCUMENTS, AND TOOLS/EQUIPMENT

The following documents should be referenced to assist in completing the associated task.

P&IDS	
DRAWINGS	
RELATED SOPs/PROCEDURES/ WORK PLANS	SOP-GEOPROBE-03 Starting and Stopping the Kubota Engine
TOOLS	
FORMS/CHECKLIST	

APPROVALS/CONCURRENCE

By signing this document, all parties acknowledge the completeness and applicability of this SOP for its intended purpose. Also, by signing this document, it serves as acknowledgement that I have received training on the procedure and associated competency testing.

SOP TECHNICAL AUTHOR	DATE
SAFETY AND HEALTH MANAGER	DATE



**SOP-GEOPROBE-04;
DRIVING AND POSITIONING THE
GEOPROBE® MODEL 7822DT**

**STATUS: DRAFT
DATE ISSUED:
11/16/2020
REVISION: 1
PAGE 8 of 8**

APPROVALS/CONCURRENCE

By signing this document, all parties acknowledge the completeness and applicability of this SOP for its intended purpose. Also, by signing this document, it serves as acknowledgement that I have received training on the procedure and associated competency testing.

Revisions:

Revision	Description	Date
1	Updates to SOP to reflect Geoprobe ® Model 7822DT	11/16/2020



**SOP-GEOPROBE-05;
GEOPROBE® DT-22
DUAL TUBE SAMPLING SYSTEM**

STATUS: DRAFT
DATE ISSUED:
11/16/2020
REVISION: 1
PAGE 1 of 11

PURPOSE	To provide standard instructions for constructing tool strings and sampling procedures using the Geoprobe® Model DT-22 Dual Sampling System.
SCOPE	This practice has been prepared for the Pioneer Technical Services, Inc. (Pioneer) workforce and applies to work carried out by and on behalf of Pioneer. All members of the Pioneer workforce who conduct the work shall be trained and competent in the risk-assessed work described below.

WORK INSTRUCTIONS

The following instructions are intended to provide sufficient guidance to perform the task in a safe, accurate, and reliable manner. Should these instructions present information that is inaccurate or unsafe, operations personnel must bring the issue to the attention of the Project Manager and the appropriate revisions made. All work carried under this SOP will be consistent with procedures and policies described in the appropriate Operation, Maintenance, and Monitoring (O&M) Plan (where applicable), appropriate Site-Specific Health and Safety Plan (SSHASP), and Pioneer Corporate Health and Safety Plan (HASP).

TASK	INSTRUCTIONS
DT-22 Expendable Cutting Shoe Tool String Set Up	<p>The procedure for operating the Geoprobe® can be reviewed in SOP-GEOPROBE-07 (Operating the Geoprobe® During Probing Operations).</p> <p>Figure 1 depicts the DT-22 tool string diagram. The expendable cutting shoes are used to collect soil samples. When sampling is complete, tooling or materials (e.g., monitoring wells) can be placed or constructed inside the probe rod string. The following instructions describe how to set up the expendable cutting shoe tool string.</p> <ol style="list-style-type: none"> 1. The expendable cutting shoe has two spaces on the neck portion of the tool. Lubricate a single O-ring with Liquinox soap solution. Place the lubricated O-ring on the top most groove. 2. Take the expendable cutting shoe, with the O-ring inserted, and place the cutting shoe into the expendable cutting shoe holder. 3. Thread the expendable cutting shoe holder onto the female end of the 2.25-inch probe rod. 4. Attach the 1.125-inch clear plastic core liner to the liner driver head. <ul style="list-style-type: none"> • Take a small piece of light weight inner rod and secure it in the pipe tri-stand. • Thread the liner driver head into the piece of lightweight inner rod. • Push the core liner onto the liner driver head and line up the hole on the top part of the core liner with the set screw hole on the liner drive head. • Place a set screw in the hole and tighten it down with a 3/32 allen wrench.



**SOP-GEOPROBE-05;
GEOPROBE® DT-22
DUAL TUBE SAMPLING SYSTEM**

STATUS: DRAFT
DATE ISSUED:
11/16/2020
REVISION: 1
PAGE 2 of 11

	<p>5. Unscrew the liner drive head with the sample core liner attached and place it inside the probe rod.</p> <p>NOTE: if the bore hole is deeper than four feet, then additional light weight center rods need to be attached to the liner drive head so that four feet of lightweight center rod protrudes out of the outer probe rod in the ground.</p> <p>6. Place an extra four feet of light weight center rod onto the center rods or sample drive head.</p> <p>7. Place another outer probe rod over the light weight center rod and thread it onto the lower probe rod until the joint is tight. Tighten joint with a pipe wrench.</p> <p>8. Place the rubber bumper onto the top light weight center rod or the liner drive head.</p> <p>9. Place the drive cap over the threads of the probe rods. The tool string is now complete and ready for probing.</p>
<p>DT-22 Attached Cutting Shoe Tool String Set Up</p>	<p>The attached cutting shoes are used to collect soil samples.</p> <p>1. Thread the attached cutting shoe onto the female end of the DT-22 probe rod.</p> <p>2. Attach the 1.125-inch clear plastic core liner to the liner driver head.</p> <ul style="list-style-type: none"> • Take a small piece of light weight inner rod and secure it in the pipe tri-stand. • Thread the liner driver head into the piece of lightweight inner rod. • Push the core liner onto the liner driver head and line up the hole on the top part of the core liner with the set screw hole on the liner drive head. • Place a set screw in the hole and tighten it down with a 3/32 allen wrench. <p>3. Unscrew the liner drive head with the sample core liner attached and place it inside the probe rod.</p> <p>NOTE: if the bore hole is deeper than four feet, then additional light weight center rods need to be attached to the liner drive head so that four feet of lightweight center rod protrude out of the probe rod in the ground.</p> <p>4. Place an extra four feet of light weight center rod onto the center rods or sample drive head.</p> <p>5. Place another outer probe rod over the light weight center rod and thread it onto the lower probe rod until the joint is tight. Use pipe wrench to</p>



**SOP-GEOPROBE-05;
GEOPROBE® DT-22
DUAL TUBE SAMPLING SYSTEM**

STATUS: DRAFT
DATE ISSUED:
11/16/2020
REVISION: 1
PAGE 3 of 11

	<p>tighten the joint.</p> <ol style="list-style-type: none"> 6. Place the rubber bumper onto the top light weight center rod or the liner drive head. 7. Place the drive cap over the threads of the probe rods. The tool string is now complete and ready for probing.
<p>DT-22 Expendable Point Tool String Set Up</p>	<p>The expendable points are used when collection of soil samples is not needed, but tooling or materials (e.g., monitoring wells) are to be placed or constructed inside the hole.</p> <ol style="list-style-type: none"> 1. The expendable point has two grooves on the neck portion of the tip. Lubricate a single O-ring with Liquinox soap solution. Place the lubricated O-ring in the upper groove. 2. Take the expendable point, with the O-ring inserted, and place the cutting shoe into the expendable point holder. 3. Thread the expendable point holder onto the female end of the 2.25-inch probe rod. 4. Place the drive cap over the threads of the probe rods. The tool string is now complete and ready for probing.
<p>Threaded Point Tool String Set Up</p>	<p>The threaded point is used when collecting samples is not needed and tooling or equipment (e.g., monitoring wells) will not be placed or constructed inside the hole.</p> <ol style="list-style-type: none"> 1. Thread the attached point holder onto the female end of the 2.25-inch probe rod. 2. Place the drive cap over the threads of the probe rods. The tool string is now complete and ready for probing.
<p>Cutting the DT-22 Sample Liners</p>	<ol style="list-style-type: none"> 1. Unfold and setup the sample table. 2. Place the aluminum sample core liner holder on the table and fasten the holder to the table with hand clamps. 3. Place the core liner that needs to be sampled in the aluminum holder tray. Place the liner so that the core catcher end of the liner slides over the sample tray retaining pin. 4. Place the DT-22 core liner cutter at the top of the core liner and pulled the length of the core liner. This operation will cut the core liner and make it possible to acquire the soil samples inside the core liner.



**SOP-GEOPROBE-05;
GEOPROBE® DT-22
DUAL TUBE SAMPLING SYSTEM**

STATUS: DRAFT
DATE ISSUED:
11/16/2020
REVISION: 1
PAGE 4 of 11

HSSE CONSIDERATIONS
This section to be completed with concurrence from the Safety and Health Manager.

<i>SOURCE</i>	<i>HAZARDS</i>	<i>WHERE</i>	<i>HOW, WHEN, RESULT</i>	<i>CONTROLS</i>
CHEMICAL	Contact with impacted soils and water.	Impacted sites, during sample collection and handling.	Adverse health effects could result from ingesting, inhaling, and/or skin/eye contact with impacted soils and water.	Personnel will practice proper personal hygiene – wash hands prior to eating/drinking and when leaving the site. Employees will wear nitrile gloves when collecting and handling samples. Employees will wear work gloves when handling probe rods. Work will be suspended during high wind conditions that produce large amounts of visible impacted dust.
	Hydraulic fluid and diesel.	Geoprobe®.	Employees could be exposed to hydraulic fluid and/or diesel via inhalation, ingestion, and skin/eye contact, when operating the Geoprobe®, or if equipment malfunctions resulting in adverse health effects.	Employees will wear work gloves and eye protection, if contact with hydraulic fluid/diesel is possible. In the event of a spill/leak, personnel will contain the fluid using the spill cleanup material available in the Geoprobe® trailer. Cleanup materials will be disposed of according to the appropriate regulations. All components of the rig will be inspected prior to and at the completion of the task. Non-essential personnel will maintain a 20-foot buffer zone around the equipment.
	Lubricating grease.	Probing location.	Employees could be exposed to lubricating grease via ingestion and skin/eye contact when assembling probe rods resulting in adverse health effects.	Employees will wear work gloves and eye protection when assembling probe rods.



**SOP-GEOPROBE-05;
GEOPROBE® DT-22
DUAL TUBE SAMPLING SYSTEM**

**STATUS: DRAFT
DATE ISSUED:
11/16/2020
REVISION: 1
PAGE 5 of 11**

	Liquinox	Probing location.	Employees could be exposed to Liquinox via ingestion and skin/eye contact when assembling probe rods resulting in adverse health effects.	Employees will wear work gloves and eye protection when assembling probe rods.
NOISE	Elevated noise levels.	Geoprobe®.	Employees could be exposed to elevated noise levels when operating the Geoprobe® resulting in irritability, decreased concentration, and noise-induced hearing loss.	Personnel within a 20-foot buffer zone of the Geoprobe® will wear single hearing protection (e.g. earmuffs or earplugs). Non-essential personnel will maintain a 20-foot buffer zone around the Geoprobe®.
ELECTRICAL	Defective electrical lines.	Geoprobe®.	Contact with defective electrical lines could result in personal injury.	Inspect electrical lines of the Geoprobe® prior to and at the completion of the task. Do not operate the Geoprobe® if defective electrical lines are found.
BODY MECHANICS	Lifting and moving rods.	Probing location.	Employees could be exposed to back or muscle strains or sprains when lifting or connecting the Geoprobe® rods.	Employees will follow good lifting techniques including lifting with the legs and not the back, get a good grip, and keep the load close to your body. Two employees will lift the rods if necessary.



**SOP-GEOPROBE-05;
GEOPROBE® DT-22
DUAL TUBE SAMPLING SYSTEM**

STATUS: DRAFT
DATE ISSUED:
11/16/2020
REVISION: 1
PAGE 6 of 11

GRAVITY	Falls from slips and trips.	Uneven terrain, slick/muddy/wet surfaces and steep slopes.	Walking on slick/muddy/wet and uneven terrain could cause slips and trips resulting in falls and injuries.	Workers will wear work boots with good traction and ankle support. Employees will plan their path and walk cautiously. Keep work area free of tools/rods. If conditions are wet/muddy, muck boots may be worn. Site can be cleared of snow, if applicable.
	Falling rods.	Probing location.	Heavy rods could slip off of worker's hands while carrying and assembling tool strings causing personal injury.	Employees will use work gloves when assembling and handling rods. Two workers will carry rods, if necessary. All personnel will wear steel-toe boots.
WEATHER	Cold/heat stress	Outdoors.	Exposure to cold climates may result in cold burns, frostbites, and hypothermia. Exposure to high temperatures may result in heat cramps, heat exhaustion, or heat stroke.	Training on signs and symptoms of cold/heat stress is required. Personnel will wear appropriate clothing when working outdoors (e.g. layers). Employees will remain hydrated and will have sufficient caloric intakes during the day. Personnel will follow procedures outlined in applicable SSHASP and/or Pioneer corporate HASP.
	Lightning.	Sites.	Electrocution, injury, death, or equipment damage could be caused by lightning strike.	Employees will follow the 30/30 rule during lightning storms. When the Geoprobe® is running, the Geoprobe helper will watch/listen for lightning and thunder.
RADIATION	Ultraviolet (UV) radiation.	Outdoors.	Employees could be exposed to UV radiation during summer months causing sun	Employees will wear sunscreen, long-sleeve work shirts and long pants. Employees will also use safety glasses with tinted lenses.



**SOP-GEOPROBE-05;
GEOPROBE® DT-22
DUAL TUBE SAMPLING SYSTEM**

STATUS: DRAFT
DATE ISSUED:
11/16/2020
REVISION: 1
PAGE 7 of 11

			burns, skin damage, and eye damage.	
BIOLOGICAL	Inexperienced and improperly trained worker. Plants, insects, and animals.	Sites. Sites.	Inexperienced workers and improper training could cause incidents resulting in adverse health effects and/or property damage. Exposure to plants, insects, and/or animals may cause rashes, blisters, redness, and swelling.	Employees will be properly trained in this procedure and other applicable procedures. All employees operating the Geoprobe® will be familiar with the basic controls of the machine including the Emergency Kill switch button. Training on the signs and symptoms of exposure to plants, insects, and animals. Avoid contact with plants, insects, and animals. First-aid kits will be available on site. Employees with allergies should notify their supervisor.
MECHANICAL	Improper body mechanics. Pinch points.	Assembling and handling rods/sample tubes. During equipment assembly and when cutting sample liners.	Improper lifting, bending, squatting, and kneeling could result in muscle/back strains or other injuries. Employees could be exposed to hand injuries such as lacerations, punctures, cuts, and pinched	Personnel will use proper lifting techniques – get a good grip, keep the load close to the body, lift with legs and not with back, and avoid lifting loads above shoulder height. Two people will lift, if necessary. Employees should stretch prior to starting work and they will take breaks when necessary. Employees will wear work gloves when assembling probe rods and sample casings, using the liner cutter, and handling plastic core liners after they have been cut open.



**SOP-GEOPROBE-05;
GEOPROBE® DT-22
DUAL TUBE SAMPLING SYSTEM**

STATUS: DRAFT
DATE ISSUED:
11/16/2020
REVISION: 1
PAGE 8 of 11

	Flying debris.	Probing location.	<p>fingers when assembling probe rods and sample casings, and when using the liner cutter.</p> <p>Eye injuries could result from flying debris when assembling probe rods and sample casings.</p>	<p>Workers will be trained on how to properly use the liner cutter.</p> <p>Employees will wear safety glasses at all times during Geoprobe® operations.</p>
PRESSURE	Pressurized hydraulic lines.	Geoprobe®.	Faulty pressurized hydraulic lines could burst resulting in personal injury/exposure and hydraulic fluid release.	All components of the rig will be inspected prior to and at the completion of the task.
THERMAL	Cold/heat stress.	Outdoors.	Exposure to cold climates may result in cold burns, frostbites, and hypothermia. Exposure to high temperatures may result in heat cramps, heat exhaustion, or heat stroke.	Training on signs and symptoms of cold/heat stress. Personnel will wear appropriate clothing when working outdoors. Employees will remain hydrated and will have sufficient caloric intakes during the day. Personnel will follow procedures outlined in applicable SSHASP and/or Pioneer corporate HASP.
HUMAN FACTORS	Inexperience and improperly trained worker.	Sites.	Inexperience workers and improper training could cause incidents resulting in personal injuries and/or property damage.	Employees will be properly trained in his procedure and other applicable procedures. When starting/stopping for the first time, an experienced operator should be on site to help coach the process. All employees operating the Geoprobe® will be familiar with the basic



**SOP-GEOPROBE-05;
GEOPROBE® DT-22
DUAL TUBE SAMPLING SYSTEM**

**STATUS: DRAFT
DATE ISSUED:
11/16/2020
REVISION: 1
PAGE 9 of 11**

				controls of the machine including the Emergency kill switch button. Employees will implement stop work procedures, if necessary.
SIMOPS	Not applicable.			

ADDITIONAL HSSE CONSIDERATIONS
This section to be completed with concurrence from the Safety and Health Manager.

REQUIRED PPE	Level D PPE.
APPLICABLE SDS	SDSs will be maintained based on site characterization and contaminants. Hydraulic fluid, diesel, Liquinox, and lubricating grease.
REQUIRED PERMITS/FORMS	Per site/project requirements.
ADDITIONAL TRAINING	Per site/project requirements.

DRAWINGS, DOCUMENTS, AND TOOLS/EQUIPMENT
The following documents should be referenced to assist in completing the associated task.

P&IDS	
DRAWINGS	
RELATED SOPs/PROCEDURES/WORK PLANS	SOP-GEOPROBE-07 Operating the Geoprobe® During Probing Operations
TOOLS	
FORMS/CHECKLIST	

APPROVALS/CONCURRENCE
By signing this document, all parties acknowledge the completeness and applicability of this SOP for its intended purpose. Also, by signing this document, it serves as acknowledgement that I have received training on the procedure and associated competency testing.

SOP TECHNICAL AUTHOR	DATE
SAFETY AND HEALTH MANAGER	DATE



**SOP-GEOPROBE-05;
GEOPROBE® DT-22
DUAL TUBE SAMPLING SYSTEM**

**STATUS: DRAFT
DATE ISSUED:
11/16/2020
REVISION: 1
PAGE 10 of 11**

APPROVALS/CONCURRENCE

By signing this document, all parties acknowledge the completeness and applicability of this SOP for its intended purpose. Also, by signing this document, it serves as acknowledgement that I have received training on the procedure and associated competency testing.

--	--

Revisions:

Revision	Description	Date
1	Updates to SOP to reflect Geoprobe ® Model 7822DT	11/16/2020

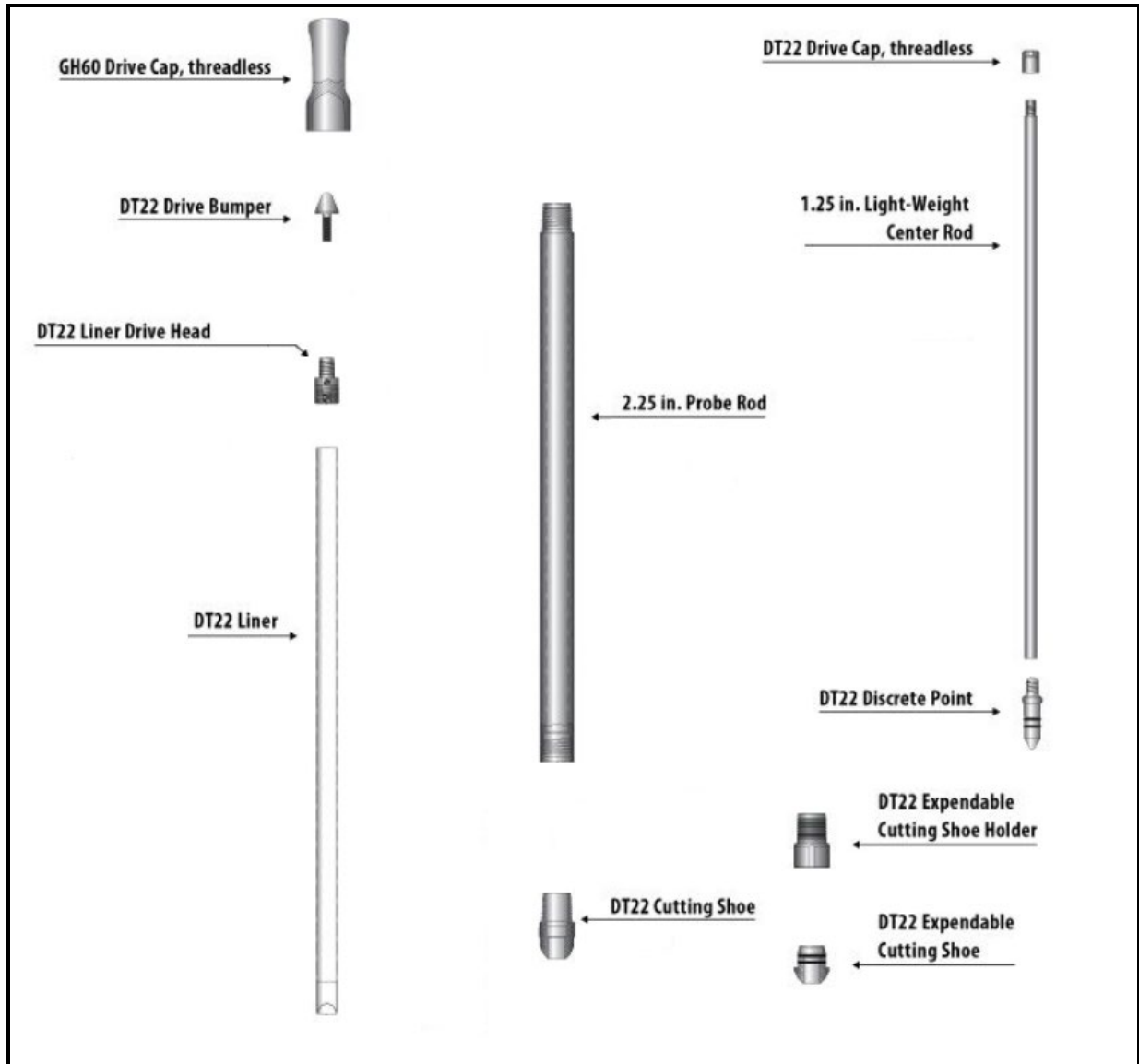

Figure 1 - The DT-22 Tool String Diagram



**SOP-GEOPROBE-06;
GEOPROBE® DT-325/375
DUAL TUBE SAMPLING SYSTEM**

STATUS: DRAFT
DATE ISSUED:
11/16/2020
REVISION: 1
PAGE 1 of 12

PURPOSE	To provide standard instructions for constructing tool strings and sampling procedures using the Geoprobe® DT-325/375 Dual Tube Sampling System and the 3.25 and 3.75-inch probe rod. Both the 3.25- and 3.75-inch rods follow the same procedure for set up and operation. Each system has unique cutting shoes, expandable points, etc. specific to the size probe rods being used, but set up and operations are identical.
SCOPE	This practice has been prepared for the Pioneer Technical Services, Inc. (Pioneer) workforce and applies to work carried out by and on behalf of Pioneer. All members of the Pioneer workforce who conduct the work shall be trained and competent in the risk-assessed work described below.

WORK INSTRUCTIONS

The following instructions are intended to provide sufficient guidance to perform the task in a safe, accurate, and reliable manner. Should these instructions present information that is inaccurate or unsafe, operations personnel must bring the issue to the attention of the Project Manager and the appropriate revisions made. All work carried under this SOP will be consistent with procedures and policies described in the appropriate Operation, Maintenance, and Monitoring (O&M) Plan (where applicable), appropriate Site-Specific Health and Safety Plan (SSHASP), and Pioneer Corporate Health and Safety Plan (HASP).

TASK	INSTRUCTIONS
DT-325/375 Expandable Cutting Shoe Tool String Set Up	<p>The procedure for operating the Geoprobe® can be reviewed in SOP-GEOPROBE-07 (Operating the Geoprobe® During Probing Operations).</p> <p>Figure 1 depicts the DT-325/375 tool string diagram. The expandable cutting shoes are used to collect soil samples during probe string advancement. When soil sampling is complete, tooling or materials (e.g., monitoring wells) can be placed or constructed inside the probe rod string, leaving the expandable cutting shoe at the bottom of the probe hole as the probe rod is removed from the hole. The following instructions describe how to assemble the expandable cutting shoe tool string.</p> <ol style="list-style-type: none"> 1. The expandable cutting shoe has two grooves on the neck portion of the cutting shoe. Lubricate a single O-ring with Liquinox soap solution. Place the lubricated O-ring on the top-most groove. 2. Take the expandable cutting shoe, with the O-ring installed, and push the cutting shoe into the expandable cutting shoe holder. Thread the expandable cutting shoe holder onto the female end of the 3.25/3.75-inch probe rod. 3. Prepare the soil sample sheath assembly using the following steps: <ul style="list-style-type: none"> • Press a DT-325/375 ring retainer onto the bottom end of the 2.1-inch diameter clear plastic core liner. • Slide the sample tube assembly into the sample sheath and thread the ring retainer into the sample sheath. If a core catcher is used, ensure it is on the end with the ring retainer. • Thread sheath drive head on top portion of the sample sheath.



**SOP-GEOPROBE-06;
GEOPROBE® DT-325/375
DUAL TUBE SAMPLING SYSTEM**

STATUS: DRAFT
DATE ISSUED:
11/16/2020
REVISION: 1
PAGE 2 of 12

	<ul style="list-style-type: none"> • Place the sample sheath assembly into the lead probe rod with the expendable cutting shoe. • Place the centering drive cap on the sheath drive head. • Place 3.25/3.75-inch drive cap on the outer probe string. • The tool string is now ready to drive and samples the first interval. <ol style="list-style-type: none"> 4. Drive the tool string to depth. 5. Remove outer drive cap and then the inner centering drive cap. 6. Thread the 1.25-inch Tee-handle on to the sheath drive head and pull the sample sheath from the outer rod. 7. Unthread the ring retainer to remove the plastic liner containing the soil core. Decontaminate the sample sheath and components as required and reassemble using a new plastic liner as described in step 3 above. 8. Place a four (or five) foot light weight center rod onto the sample drive head and lower the sampler back into the outer probe rod remaining in the ground until it seats into the outer rod assembly. This will leave a light weight center rod sticking 4 (or 5) feet above the top of the outer rod. 9. Place another outer probe rod over the light weight center rod and thread it onto the lower probe rod until the joint is tight. Tighten joint with a pipe wrench if necessary. 10. Place the inner drive cap onto the top of the light weight center rod followed by the placement of the outer drive cap over the threads of the probe rods. <p>The tool string is now complete and ready to probe and sample the next interval. The process is repeated by adding a light weight center rod and outer probe rod each interval until final depth is achieved. Installation of a well or other equipment can now proceed.</p>
<p>DT-325/375 Threaded Cutting Shoe Tool String Set Up</p>	<p>The threaded cutting shoes are used to collect soil samples. The fixed cutting shoe limits the size and placement of well materials, and therefore is typically used only for collecting soil cores. However, small diameter wells or piezometers can be placed through the center of the cutting shoe.</p> <ol style="list-style-type: none"> 1. Thread the cutting shoe onto the female end of the DT-325/375 probe rod. 2. Prepare the sample sheath assembly using the following steps:



**SOP-GEOPROBE-06;
GEOPROBE® DT-325/375
DUAL TUBE SAMPLING SYSTEM**

STATUS: DRAFT
DATE ISSUED:
11/16/2020
REVISION: 1
PAGE 3 of 12

	<ul style="list-style-type: none"> • Press a DT-325/375 ring retainer onto the bottom end of the 2.1-inch diameter clear plastic core liner. • Slide the sample tube assembly into the sample sheath and thread the ring retainer into the sample sheath. If a core catcher is used, ensure it is on the end with the ring retainer. • Thread sheath drive head on top portion of the sample sheath. • Place the sample sheath assembly into the lead probe rod with the threaded cutting shoe. • Place the centering drive cap on the sheath drive head. • Place 3.25/3.75-inch drive cap on the outer probe string. • The tool string is now ready to drive and samples the first interval. <ol style="list-style-type: none"> 3. Drive the tool string to depth. 4. Remove outer drive cap and then the inner centering drive cap. 5. Thread the 1.25-inch Tee-handle on to the sheath drive head and pull the sample sheath from the outer rod. 6. Unthread the ring retainer to remove the plastic liner containing the soil core. Decontaminate the sample sheath and components as required and reassemble using a new plastic liner as described in step 2 above. 7. Place a four (or five) foot light weight center rod onto the center rods or sample drive head and lower the sampler back into the outer probe rod remaining in the ground until it seats into the outer rod assembly. This will leave a light weight center rod sticking 4 (or 5) feet above the top of the outer rod. 8. Place another outer probe rod over the light weight center rod and thread it onto the lower probe rod until the joint is tight. Tighten joint with a pipe wrench if necessary. 9. Place the inner drive cap onto the top light weight center rod followed by the placement of the outer drive cap over the threads of the probe rods.
<p>DT-325/375 Expendable Point Tool String Set Up</p>	<p>The expendable points are used when collection of soil samples is not needed, but tooling or materials (e.g., monitoring wells) are to be placed or constructed through the outer rods.</p> <ol style="list-style-type: none"> 1. The expendable point has two grooves on the neck portion of the tip. Lubricate a single O-ring with Liquinox soap solution. Place the lubricated O-ring in the upper groove.



**SOP-GEOPROBE-06;
 GEOPROBE® DT-325/375
 DUAL TUBE SAMPLING SYSTEM**

STATUS: DRAFT
DATE ISSUED:
 11/16/2020
REVISION: 1
PAGE 4 of 12

	<ol style="list-style-type: none"> 2. Take the expendable point, with the O-ring inserted, and place the point into the expendable point holder 3. Thread the expendable point holder onto the female end of the 3.25/3.75-inch probe rod. 4. Place the outer drive cap over the threads of the probe rods. The tool string is now ready for probing. 5. Drive the probe rod the full interval. 6. Continue to add a new 3.25/3.75-inch probe rod as the probe string is advanced each interval. 7. Continue driving the 3.25/3.75-inch rods until the desired depth is reached.
<p>Threaded Point Tool String Set Up</p>	<p>The threaded point is used when collecting samples is not needed and tooling or equipment (e.g., monitoring wells) will not be placed or constructed inside the hole.</p> <ol style="list-style-type: none"> 1. Thread the solid point onto the female end of the 3.25/3.75-inch probe rod. 2. Place the outer drive cap over the threads of the probe rods. <p>The tool string is now complete and ready for probing.</p>
<p>Cutting the DT-325/375 Sample Liners</p>	<ol style="list-style-type: none"> 1. Unfold and setup the sample table. 2. Place the aluminum sample core liner holder on the table and fasten the holder to the table with hand clamps. 3. Place the core liner that needs to be sampled in the aluminum holder tray. Place the liner so that the core catcher end of the liner slides over the sample tray retaining pin. 4. Place the DT-325/375 core liner cutter at the top of the core liner and pull the length of the core liner. This operation will cut the core liner and make it possible to acquire the soil samples inside the core liner.



**SOP-GEOPROBE-06;
GEOPROBE® DT-325/375
DUAL TUBE SAMPLING SYSTEM**

STATUS: DRAFT
DATE ISSUED:
11/16/2020
REVISION: 1
PAGE 5 of 12

<p>Pulling 3.25/3.75-inch rods from the ground using threaded pull cap</p>	<ol style="list-style-type: none"> 1. Thread pull cap on top of the rod string to be extracted from the ground. 2. Move Geoprobe head with rod puller into position to pull the rod. 3. Begin pulling rod out of ground until the pull cap is at full height. 4. Place rod clamp around rods at ground level and clamp tightly. 5. Relax the pull on the rods by moving the Geoprobe head down slightly, allowing the pull bar to be moved away from the pull cap. 6. Remove pull cap. 7. Remove upper rod from the rod string. 8. Replace threaded pull cap on remaining rod string and repeat the process until all the rods have been removed from the ground.
<p>Pulling 3.25/3.75-inch rods from the ground using external rod grip system</p>	<ol style="list-style-type: none"> 1. Move Geoprobe head into position to where the leaf pull plates line up on rod. If the rod was originally driven to ground level, thread a 2-foot rod on the string to extend the string, allowing the rod grip system to grab the rod string. 2. Install rod grip tool by aligning the pull pins on the head with the tool. 3. Begin pulling rods from the ground. 4. Once at the top of the pull, install the rod clamp at ground level to secure the rod string. 5. Relax the pull of the Geoprobe head and remove the rod grip tool. 6. Move the Geoprobe head back away from the rod and remove the upper rod. 7. Repeat the procedure until all rods have been removed from the ground.

HSSE CONSIDERATIONS				
This section to be completed with concurrence from the Safety and Health Manager.				
<i>SOURCE</i>	<i>HAZARDS</i>	<i>WHERE</i>	<i>HOW, WHEN, RESULT</i>	<i>CONTROLS</i>
CHEMICAL	Contact with impacted soils and water.	Impacted sites, during sample collection and handling.	Adverse health effects could result from ingesting, inhaling, and/or skin/eye contact with impacted	Personnel will practice proper personal hygiene – wash hands prior to eating/drinking and when leaving the site. Employees will wear nitrile gloves when collecting and handling samples. Employees



**SOP-GEOPROBE-06;
 GEOPROBE® DT-325/375
 DUAL TUBE SAMPLING SYSTEM**

**STATUS: DRAFT
 DATE ISSUED:
 11/16/2020
 REVISION: 1
 PAGE 6 of 12**

	Hydraulic fluid and diesel.	Geoprobe®.	soils and water. Employees could be exposed to hydraulic fluid and/or diesel via inhalation, ingestion, and skin/eye contact, when operating the Geoprobe®, or if equipment malfunctions resulting in adverse health effects.	will wear work gloves when handling probe rods. Work will be suspended during high wind conditions that produce large amounts of visible impacted dust. Employees will wear work gloves and eye protection, if contact with hydraulic fluid/diesel is possible. In the event of a spill/leak, personnel will contain the fluid using the spill cleanup material available in the Geoprobe® trailer. Cleanup materials will be disposed of according to the appropriate regulations. All components of the rig will be inspected prior to and at the completion of the task. Non-essential personnel will maintain a 20-foot buffer zone around the equipment.
	Lubricating grease.	Probing location.	Employees could be exposed to lubricating grease via ingestion and skin/eye contact when assembling probe rods resulting in adverse health effects.	Employees will wear work gloves and eye protection when assembling probe rods.
	Liquinox	Probing location.	Employees could be exposed to Liquinox via ingestion and skin/eye contact when assembling probe rods resulting in adverse health effects.	Employees will wear work gloves and eye protection when assembling probe rods.
NOISE	Elevated noise levels.	Geoprobe®.	Employees could be exposed to	Personnel within a 20-foot buffer zone of the Geoprobe®



**SOP-GEOPROBE-06;
GEOPROBE® DT-325/375
DUAL TUBE SAMPLING SYSTEM**

**STATUS: DRAFT
DATE ISSUED:
11/16/2020
REVISION: 1
PAGE 7 of 12**

			elevated noise levels when operating the Geoprobe® resulting in irritability, decreased concentration, and noise-induced hearing loss.	will wear single hearing protection (e.g. earmuffs or earplugs). Non-essential personnel will maintain a 20-foot buffer zone around the Geoprobe®.
PRESSURE	Pressurized hydraulic lines.	Geoprobe®.	Faulty pressurized hydraulic lines could burst resulting in personal injury/exposure and hydraulic fluid release.	All components of the rig will be inspected prior to and at the completion of the task.
ELECTRICAL	Defective electrical lines. Lightning.	Geoprobe®. All sites.	Contact with defective electrical lines could result in personal injury. Electrocution, injury, death, or equipment damage could be caused by lightning strike.	Inspect electrical lines of the Geoprobe® prior to and at the completion of the task. Employees will follow the 30/30 rule during lightning storms.
BODY MECHANICS	Lifting and moving rods.	Probing location.	Employees could be exposed to back or muscle strains or sprains when lifting or connecting the Geoprobe® rods.	Employees will follow good lifting techniques including lifting with the legs and not the back, get a good grip, and keep the load close to your body. Two employees will lift the rods if necessary.
GRAVITY	Falls from slips and trips.	Uneven terrain, slick/muddy/wet surfaces and steep slopes.	Walking on slick/muddy/wet and uneven terrain could cause slips and trips resulting in falls and injuries.	Workers will wear work boots with good traction and ankle support. Employees will plan their path and walk cautiously. Keep work area free of tools/rods. If conditions are wet/muddy, muck boots may



**SOP-GEOPROBE-06;
GEOPROBE® DT-325/375
DUAL TUBE SAMPLING SYSTEM**

**STATUS: DRAFT
DATE ISSUED:
11/16/2020
REVISION: 1
PAGE 8 of 12**

	Falling rods.	Probing location.	Heavy rods could slip off of worker's hands while carrying and assembling tool strings causing personal injury.	be worn. Site can be cleared of snow, if applicable. Employees will use work gloves when assembling and handling rods. Two workers will carry rods, if necessary. All personnel will wear steel-toe boots.
WEATHER	Cold/heat stress	Outdoors.	Exposure to cold climates may result in cold burns, frostbites, and hypothermia. Exposure to high temperatures may result in heat cramps, heat exhaustion, or heat stroke.	Training on signs and symptoms of cold/heat stress is required. Personnel will wear appropriate clothing when working outdoors (e.g. layers). Employees will remain hydrated and will have sufficient caloric intakes during the day. Personnel will follow procedures outlined in applicable SSHASP and/or Pioneer corporate HASP.
	Lightning.	Sites.	Electrocution, injury, death, or equipment damage could be caused by lightning strike.	Employees will follow the 30/30 rule during lightning storms. When the Geoprobe® is running, the Geoprobe helper will watch/listen for lightning and thunder.
RADIATION	Ultraviolet (UV) radiation.	Outdoors.	Employees could be exposed to UV radiation during summer months causing sun burns, skin damage, and eye damage.	Employees will wear sunscreen, long-sleeve work shirts and long pants. Employees will also use safety glasses with tinted lenses.
BIOLOGICAL	Inexperienced and improperly trained worker.	Sites.	Inexperienced workers and improper training could cause incidents resulting in adverse health effects and/or	Employees will be properly trained in this procedure and other applicable procedures. All employees operating the Geoprobe® will be familiar with the basic



**SOP-GEOPROBE-06;
GEOPROBE® DT-325/375
DUAL TUBE SAMPLING SYSTEM**

**STATUS: DRAFT
DATE ISSUED:
11/16/2020
REVISION: 1
PAGE 9 of 12**

	Plants, insects, and animals.	Sites.	property damage. Exposure to plants, insects, and/or animals may cause rashes, blisters, redness, and swelling.	controls of the machine including the Emergency Kill switch button. Training on the signs and symptoms of exposure to plants, insects, and animals. Avoid contact with plants, insects, and animals. First-aid kits will be available on site. Employees with allergies should notify their supervisor.
MECHANICAL	Improper body mechanics.	Assembling and handling rods/sample tubes.	Improper lifting, bending, squatting, and kneeling could result in muscle/back strains or other injuries.	Personnel will use proper lifting techniques – get a good grip, keep the load close to the body, lift with legs and not with back, and avoid lifting loads above shoulder height. Two people will lift, if necessary. Employees should stretch prior to starting work and they will take breaks when necessary.
	Pinch points.	During equipment assembly and when cutting sample liners.	Employees could be exposed to hand injuries such as lacerations, punctures, cuts, and pinched fingers when assembling probe rods and sample casings, and when using the liner cutter.	Employees will wear work gloves when assembling probe rods and sample casings, using the liner cutter, and handling plastic core liners after they have been cut open. Workers will be trained on how to properly use the liner cutter.
	Flying debris.	Probing location.	Eye injuries could result from flying debris when assembling probe rods and sample casings.	Employees will wear safety glasses at all times during Geoprobe® operations.



**SOP-GEOPROBE-06;
GEOPROBE® DT-325/375
DUAL TUBE SAMPLING SYSTEM**

**STATUS: DRAFT
DATE ISSUED:
11/16/2020
REVISION: 1
PAGE 10 of 12**

PRESSURE	Pressurized hydraulic lines.	Geoprobe®.	Faulty pressurized hydraulic lines could burst resulting in personal injury/exposure and hydraulic fluid release.	All components of the rig will be inspected prior to and at the completion of the task.
THERMAL	Cold/heat stress.	Outdoors.	Exposure to cold climates may result in cold burns, frostbites, and hypothermia. Exposure to high temperatures may result in heat cramps, heat exhaustion, or heat stroke.	Training on signs and symptoms of cold/heat stress. Personnel will wear appropriate clothing when working outdoors. Employees will remain hydrated and will have sufficient caloric intakes during the day. Personnel will follow procedures outlined in applicable SSHASP and/or Pioneer corporate HASP.
HUMAN FACTORS	Inexperience and improperly trained worker.	Sites.	Inexperience workers and improper training could cause incidents resulting in personal injuries and/or property damage.	Employees will be properly trained in his procedure and other applicable procedures. When starting/stopping for the first time, an experienced operator should be on site to help coach the process. All employees operating the Geoprobe® will be familiar with the basic controls of the machine including the Emergency kill switch button. Employees will implement stop work procedures, if necessary.
SIMOPS	Not applicable.			
ADDITIONAL HSSE CONSIDERATIONS				
This section to be completed with concurrence from the Safety and Health Manager.				
REQUIRED PPE	Level D PPE.			
APPLICABLE SDS	SDSs will be maintained based on site characterization and contaminants. Hydraulic fluid, diesel, Liquinox, and lubricating grease.			



**SOP-GEOPROBE-06;
 GEOPROBE® DT-325/375
 DUAL TUBE SAMPLING SYSTEM**

**STATUS: DRAFT
 DATE ISSUED:
 11/16/2020
 REVISION: 1
 PAGE 11 of 12**

REQUIRED PERMITS/FORMS	Per site/project requirements.
ADDITIONAL TRAINING	Per site/project requirements.

DRAWINGS, DOCUMENTS, AND TOOLS/EQUIPMENT	
The following documents should be referenced to assist in completing the associated task.	
P&IDS	
DRAWINGS	
RELATED SOPs/PROCEDURES/ WORK PLANS	SOP-GEOPROBE-07 Operating the Geoprobe® During Probing Operations
TOOLS	
FORMS/CHECKLIST	

APPROVALS/CONCURRENCE	
By signing this document, all parties acknowledge the completeness and applicability of this SOP for its intended purpose. Also, by signing this document, it serves as acknowledgement that I have received training on the procedure and associated competency testing.	
SOP TECHNICAL AUTHOR	DATE
SAFETY AND HEALTH MANAGER	DATE

Revisions:

Revision	Description	Date
1	Update to SOP to reflect Geoprobe® Model 7822DT	11/16/2020

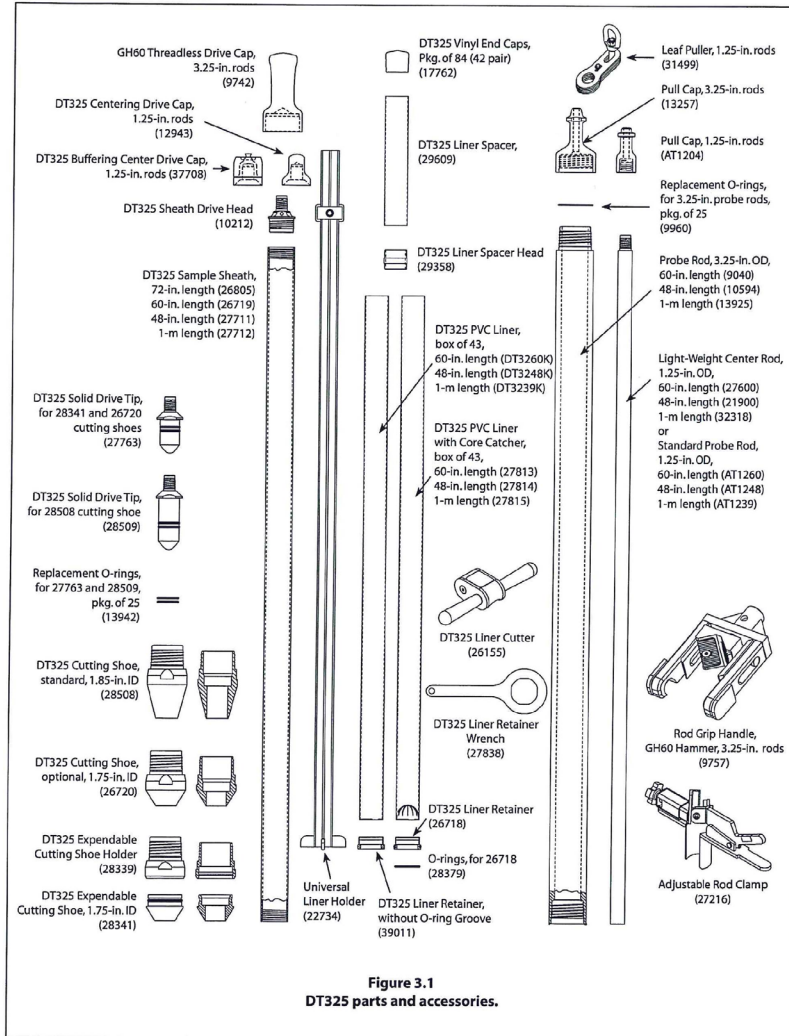

Figure 1 - The DT-325 Tool String Diagram



**SOP-GEOPROBE-07;
OPERATING THE GEOPROBE®
DURING PROBING OPERATIONS**

STATUS: DRAFT
DATE ISSUED:
11/16/2020
REVISION: 1
PAGE 1 of 16

PURPOSE	To provide standard instructions for operating the Geoprobe® Model 7822DT during probing operations.
SCOPE	This practice has been prepared for the Pioneer Technical Services, Inc. (Pioneer) workforce and applies to work carried out by and on behalf of Pioneer. All members of the Pioneer workforce who conduct the work shall be trained and competent in the risk-assessed work described below.

WORK INSTRUCTIONS

The following instructions are intended to provide sufficient guidance to perform the task in a safe, accurate, and reliable manner. Should these instructions present information that is inaccurate or unsafe, operations personnel must bring the issue to the attention of the Project Manager and the appropriate revisions made. All work carried under this SOP will be consistent with procedures and policies described in the appropriate Operation, Maintenance, and Monitoring (O&M) Plan (where applicable), appropriate Site-Specific Health and Safety Plan (SSHASP), and Pioneer Corporate Health and Safety Plan (HASP).

TASK	INSTRUCTIONS
Probe Operating Controls	<p><i>Probe</i> The Probe Control Lever operates the probe cylinder. The probe control lever will lower and raise the probe cylinder and the hammer assembly. Place the probe control lever in the downward position to lower the probe cylinder and place the probe control lever in the upward position to raise the probe cylinder. The probe cylinder uses the static weight of the machine to push/hammer the rig tooling into the ground to either conduct sampling or install wells.</p> <p><i>Hammer/Rotation</i> The Hammer/Rotation Control Lever activates and deactivates the hammer percussion and also will allow rotation when percussion is conducted. The Hammer/Rotation is used when the static weight of the machine is not enough force to push the tooling into the ground. Sometimes the hammer function is helpful when sampling and not getting very good recovery just with the static weight of the rig. The rotation is generally not used during probing operations. The rotation is typically used when using a special concrete bit to drill holes through concrete in a roto-hammer fashion.</p> <p><i>Auger</i> The Auger Control Lever controls the speed and direction of the auger head. This tool is not used in Pioneer’s probing operations.</p> <p><i>Regen (Two-Speed Pull System)</i> The Regen Control Switch activates the regenerating probe cylinder circuit. By activating the circuit, the probe cylinder will move up and down much faster. With the low speed setting (full pulling power), the full pull stroke takes 11 seconds, while on the fast speed setting, the full stroke takes 5 seconds. When using the high-speed setting, the probe cylinder will lose a lot of its pulling force. This switch is mainly used on shallow holes or at the end of the tool string on deeper holes when heavy pulling is not required.</p>



**SOP-GEOPROBE-07;
OPERATING THE GEOPROBE®
DURING PROBING OPERATIONS**

**STATUS: DRAFT
DATE ISSUED:
11/16/2020
REVISION: 1
PAGE 2 of 16**

**Probing Using Static
Weight**

When using static weight, the Geoprobe® only uses the weight of the unit to advance probe rods.

1. Drive and position the Model 7822DT at the desired sampling location. Refer to SOP-GEOPROBE-04 Driving and Positioning the Geoprobe® Model 7822DT for instructions.
2. Put a magnetic bullet level on the front of the derrick on the rig. Ensure the derrick is vertical in the fore and aft position. To plumb the derrick vertically, use the Fold Control Lever until the derrick is plumb.
3. Set up the tool string using the desired configuration for the DT-22 or the DT-325/375 dual tube systems. Refer to SOP-GEOPROBE-05 Geoprobe® DT-22 Dual Tube Sampling System and SOP-GEOPROBE-06 Geoprobe® DT-325/375 Dual Tube Sampling System for tool string diagrams and set-up procedures.
4. Position the initial pipe/tool string under the Geoprobe hammer. Lower the hammer onto the drive cap by placing the probe lever into the downward position.

CAUTION: *do not hold onto the drive cap; make sure to hold onto the push rod when lowering the probe hammer onto the drive head. This will make sure that no appendages can be pinched between the metal.*

5. Place the magnetic bullet level on the front of the pipe. Use the extend lever to get the pipe plumb fore and aft.
6. Place the magnetic bullet level on the side of the pipe . Use the swing lever to get the pipe plumb from side to side.

IMPORTANT: *ensure that the first pipe entering the ground is plumb. This will ensure there is no angle to the probe hole and will make for easier extraction when pulling the tool string out of the ground. It is best to initially check the pipe for level and then push the pipe approximately one foot into the ground and check the level again. In some instances, it may be necessary to check the rod plumb every half foot due to difficult probing conditions. Do not try to force the pipe level after the first pipe has entered the ground. This may damage the threads on the pipe and can break the pipe itself.*

7. When the first pipe/tool string is plumb, begin the push by pulling the probe lever down to start pushing the rod into the ground. Stop approximately one foot into the push and check for rod plumbness. Then continue to push the rod into the ground by pulling down on the probe lever. Check for rod plumb as necessary as the first rod is advanced. During static weight probing, the foot of the Geoprobe



**SOP-GEOPROBE-07;
OPERATING THE GEOPROBE®
DURING PROBING OPERATIONS**

STATUS: DRAFT
DATE ISSUED:
11/16/2020
REVISION: 1
PAGE 3 of 16

	<p>derrick may or may not slightly lift off of the ground. To get a feel for the machine and how hard the soil is, the operator should place their left foot on the front portion of the foot of the rig to provide feedback on how the push is progressing.</p> <p>NOTE: if the operator is recovering small soil samples, try to use the hammer lever slightly to try and vibrate the soil into the sample tube. It is very unlikely that just the static weight of the rig will be able to push the rod into the ground past four to eight feet.</p> <p>If the operator is collecting soil caps as per SOP-GEOPROBE-05 Geoprobe® DT-22 Dual Tube Sampling System and/or SOP-GEOPROBE-06 Geoprobe® DT-325/375 Dual Tube Sampling System. The remainder of the push will be completed following the appropriate SOP. If the operator is collecting soil cores, follow SOP-GEOPROBE-05 Geoprobe® DT-22 Dual Tube Sampling System and/or SOP-GEOPROBE-06 Geoprobe® DT-325/375.</p> <p>NOTE: as stated before, generally the static weight alone is not enough to reach the total depth of the hole. Do not just use static weight if one believes they have reached refusal. Refusal is when the piping will not go into the ground anymore.</p>
<p>Probing Using Percussion and Static Weight</p>	<p>The tool string cannot be advanced only of the Geoprobe weight in most soil formations. In these situations, hammer percussion must be employed as described in this section.</p> <ol style="list-style-type: none"> 1. Follow steps in task “Probing using only the static weight of the Geoprobe” prior to starting probing using percussion. 2. Put a magnetic bullet level on the front of the derrick on the rig. Ensure the derrick is vertical in the fore and aft position. To plumb the derrick vertically, use the Fold Control Lever until the derrick is plumb. 3. Place the magnetic bullet level on the side of the derrick to check the verticality side to side. Use lever to rotate derrick until plumb. Position the initial pipe/tool string under the Geoprobe hammer. Lower the hammer onto the drive cap by placing the probe lever into the downward position. <p>NOTE: Ensure that the first pipe entering the ground is plumb. This will ensure there is no angle to the probe hole and will make for easier extraction when pulling the tool string out of the ground. It is best to initially check the pipe for level and then push the pipe approximately one foot into the ground and check the level again. In some instances, it may be necessary to check the rod plumb every half foot due to difficult probing conditions. Do not try to force the pipe level after the first pipe has entered the ground. This may damage the threads on the pipe and can break the pipe itself.</p>



**SOP-GEOPROBE-07;
OPERATING THE GEOPROBE®
DURING PROBING OPERATIONS**

STATUS: DRAFT
DATE ISSUED:
11/16/2020
REVISION: 1
PAGE 4 of 16

	<p>When the first rod/tool string is plumbed, begin to pull the probe lever and the hammer/rotation lever down simultaneously to start pushing and hammering the rod into the ground. Stop part way through the push of the rod and re-plumb the pipe. Then continue to push the rod into the ground by pulling down on the probe lever and hammer/rotation lever. During percussion probing, the foot of the derrick should be lifted roughly an inch off of the ground. To get a feel for the machine and how hard the soil is, the operator should place their left foot on the front portion of the foot of the rig.</p> <ol style="list-style-type: none"> 4. <i>NOTE: the operator needs to make sure that the foot of the derrick comes off of the ground during percussion probing. If the foot is not coming off of the ground, the rubber bumpers will melt and deteriorate. This is because not enough static weight is being applied to the tool string.</i> 5. If the operator is collecting soil cores, the next step would be to pull off the drive caps and use the extraction “T” to pull the sample out of the outside casing as per SOP-GEOPROBE-05 Geoprobe® DT-22 Dual Tube Sampling System and/or SOP-GEOPROBE-06 Geoprobe® DT-325/375 Dual Tube Sampling System SOP-Geoprobe. The remainder of the push will be completed following the appropriate SOP. <p style="text-align: center;">Note: Depending on subsurface conditions, there may be instances where probe refusal is encountered. Continued hammering on a rod that is not advancing can cause damage to the rod string. The Pioneer operator needs to recognize refusal and determine the best course of action. In some instances when the probe rod encounters a small subsurface cobble, hammering on the rod will break the cobble allowing the probe string will advance. Knowing subsurface stratigraphy in advance if possible will assist in making good field decisions when it comes to refusal.</p>
<p>Adding Probe Rods, Inner Rods, and Sample Liners or Sheaths</p>	<p>Probe rods must be added to the tool string to reach the desired depth below ground surface.</p> <ol style="list-style-type: none"> 1. Using the probe control lever, raise the hammer assembly to its full height. 2. Using the extend lever, extend back as far as the rig will go. This will allow for easy access to the in-ground tool string and will allow for easy addition of probe rods and sampling equipment. 3. Remove the outer drive cap from the probe rod that was driven into the existing ground followed by removing rubber bumper and/or inner rod drive cap.



**SOP-GEOPROBE-07;
OPERATING THE GEOPROBE®
DURING PROBING OPERATIONS**

STATUS: DRAFT
DATE ISSUED:
11/16/2020
REVISION: 1
PAGE 5 of 16

	<ol style="list-style-type: none"> 4. Thread the extraction “T” to the inner rod string and use “T” to pull up to remove the inner rods and sample liner or sample sheath out of the existing probe rod string. The inner rods simply thread onto each other and to the sample core or sample sheath. Refer to SOP-GEOPROBE-05 to see the procedure and diagrams of how to set up the DT-22 Sample Core. Refer to SOP-GEOPROBE-06 to see the procedure and diagrams of how to set up the DT-325/375 Sample Sheath. 5. If retrieving cores, replace the sample core or sample sheath with a clean set and attach enough inner rod to leave an extra length of inner rod (4 feet) out of the in-ground probe rod. 6. Place a new piece of outer probe rod over the 4-foot length of inner rod sticking out of the existing hole and thread the new probe rod to the existing probe rod in the ground. Tighten the threaded joint with a pipe wrench. 7. Place inner rod drive cap and/or rubber bumper followed by the outer rod drive cap. Use the extend lever to extend the rig outward until the Geoprobe hammer is above the drive cap. 8. Slowly lower the probe cylinder onto the top probe rod with the probe control lever. 9. Advance the tool string into the ground. 10. Repeat steps 1- 9 until the desired sampling depth or refusal is reached. <p><i>IMPORTANT: do not continue probing if the tool string meets refusal. Prolonged hammering at refusal can cause damage to the tool string.</i></p>
<p>Pulling Probe Rods with the Pull Cap</p>	<p>A pull cap is used to retract probe rods from an existing bore hole, when monitoring well materials through and the rods do not need to be lifted over the well casing are not being set</p> <ol style="list-style-type: none"> 1. Raise the hammer assembly just high enough to provide access to the top probe rod. 2. Remove the drive cap from the top probe rod of the tool string. 3. Attach a pull cap to the top probe rod by threading the pull cap securely onto the probe rod. 4. Ensure that the probe foot is in contact with the ground surface. This provides support for the unit. The downward force resulting from pulling the rods may damage the unit if the foot is not supported.



**SOP-GEOPROBE-07;
OPERATING THE GEOPROBE®
DURING PROBING OPERATIONS**

STATUS: DRAFT
DATE ISSUED:
11/16/2020
REVISION: 1
PAGE 6 of 16

NOTE: if when pulling the probe rods out of the ground the foot begins to sink into the ground, then lengths of blocking should be placed under the foot to allow for more surface area to support the force on the ground.

5. Hold down on the probe control lever until the drive head is close to the pull cap.
6. Pull the pin upward to release the extraction latch and place it around the pull cap.
7. Retract the probe rod by placing the probe control lever in the upward position until motion has stopped.
8. Once the probe cylinder is all the way up and the first probe rod has been retracted, place the Kwik Klamp-pipe clamp on the lower section of the pipe. A pipe clamp is used to support the weight of the rod string so that when the extraction latch is taken off, the top piece of pipe can be unattached from the tool string without losing the rest of the tool string down the hole.
9. Lower the probe cylinder slightly so the extraction latch is free from the pull cap. Pull the extraction latch and lock it back into its locked position.
10. Place the section of pipe that was taken off of the tool string to the side or in the rod rack out of the way.
11. Repeat steps 3 through 10 until the entire tool string has been extracted from the ground.
Note: The last rod out of the ground is relatively unsupported. Special care must be taken to avoid dropping the rod back down the hole. One method to prevent rod loss is to leave the Kwik Klamp tool on the rod until the rod is well away from the probe hole. If the rod slips, the Kwik Klamp prevents the rod from getting loose and falling back into the hole.

Pulling Probe Rods with the Rod Grip Pull System

The rod grip pull system is used when installing monitoring wells and other applications when the inside of the tool string needs to be available during extraction of the probe rods.

There are three handle assemblies and jaws to accommodate the various rod sizes: 1.0-inch, 1.25-inch, 2.125-inch, 3.25-inch and 3.75-inch.

Pulling Probe Rods

In order to pull with this system, there must be enough exposed probe rod above the ground surface to allow the puller jaws to engage the outside of



**SOP-GEOPROBE-07;
OPERATING THE GEOPROBE®
DURING PROBING OPERATIONS**

**STATUS: DRAFT
DATE ISSUED:
11/16/2020
REVISION: 1
PAGE 7 of 16**

the rod. Approximately 18 inches of exposed rod is needed. If the tool string is driven too far and the puller cannot fully engage the top probe rod, simply add another rod to the tool string and reattach the handle assembly.

IMPORTANT: it is very important that the puller jaws never grip over the threaded section of a probe rod. Severe damage to the threads will result. Furthermore, avoid placing the puller near rod joints as gripping is not as effective at this location and rod deformation can occur.

1. Lower the extraction latch so it will not bind up the pipe when extracting with the rod grips.
2. Position the hammer with the jaws directly behind the top probe rod and below the threads. Take the appropriate handle assembly (according to rod diameter) and orientate the jaw cutout toward the probe rod as shown in.
3. Hook the handle over the socket head cap screws on each side of the probe cylinder.
4. To start pulling, lower the end of the handle assembly and raise the probe cylinder. This tightly clamps the jaws of the handle and probe cylinder around the probe rod. If slipping occurs, step on the end of the handle assembly to encourage the gripping action.
5. Once fully raised, place a pipe vice on top of the probe rod string below the retracted rod connection and slightly lower the probe cylinder to release the pressure on the probe rod. Lift the end of the handle to rotate the assembly on the cap screws. This moves the handle jaw away from the probe rod and disengages the puller. The probe cylinder can now be lowered to pull another section of rod. Once the rod grip puller is engaged on the next rod, the rod above is removed. Alternatively, and especially if rod deviation took place during probing operations, the rod grip puller is removed, the Geoprobe is extended inward, and the hammer is lowered into the pulling position. The Geoprobe is then extended out until the rod grips are aligned with the probe rod. The rod grip puller then is installed and used to pull the next section of probe rod. In some cases, the rod grip handle gets very tight and does not want to loosen when ready for removal. In that case, a hammer can be used on the outer end of the handle with an upward motion to loosen the puller. Before extracting the next rod, the pipe clamp is loosened. One at the top of the pull, the pipe clamp is reattached to support the rod string before releasing the rod grip system.
6. Repeat steps 2 through 5 until the in-hole tool string is fully extracted.

Note: The last rod out of the ground is relatively unsupported. Special care must be taken to avoid dropping the rod back down the hole. One method



**SOP-GEOPROBE-07;
OPERATING THE GEOPROBE®
DURING PROBING OPERATIONS**

**STATUS: DRAFT
DATE ISSUED:
11/16/2020
REVISION: 1
PAGE 8 of 16**

to prevent rod loss is to leave the Kwik Klamp tool on the rod until the rod is well away from the probe hole. If the rod slips, the Kwik Klamp prevents the rod from getting loose and falling back into the hole.



**SOP-GEOPROBE-07;
OPERATING THE GEOPROBE®
DURING PROBING OPERATIONS**

STATUS: DRAFT
DATE ISSUED:
11/16/2020
REVISION: 1
PAGE 9 of 16

HSSE CONSIDERATIONS
This section to be completed with concurrence from the Safety and Health Manager.

<i>SOURCE</i>	<i>HAZARDS</i>	<i>WHERE</i>	<i>HOW, WHEN, RESULT</i>	<i>CONTROLS</i>
CHEMICAL	Contact with impacted soils and water.	Impacted sites, during sample collection and handling.	Adverse health effects could result from ingesting, inhaling, and/or skin/eye contact with impacted soils and water.	Personnel will practice proper personal hygiene – wash hands prior to eating/drinking and when leaving the site. Employees will wear nitrile gloves when collecting and handling samples. Employees will wear work gloves when handling probe rods. Work will be suspended during high wind conditions that produce large amounts of visible impacted dust.
	Hydraulic fluid and diesel.	Geoprobe®.	Employees could be exposed to hydraulic fluid and/or diesel via inhalation, ingestion, and skin/eye contact, when operating the Geoprobe®, or if equipment malfunctions resulting in adverse health effects.	Employees will wear work gloves and eye protection, if contact with hydraulic fluid/diesel is possible. In the event of a spill/leak, personnel will contain the fluid using the spill cleanup material available in the Geoprobe® trailer. Cleanup materials will be disposed of according to the appropriate regulations. All components of the rig will be inspected prior to and at the completion of the task. Non-essential personnel will maintain a 20-foot buffer zone around the equipment.
	Lubricating grease.	Probing location.	Employees could be exposed to lubricating grease via ingestion and skin/eye contact when assembling probe rods resulting in adverse health effects.	Employees will wear work gloves and eye protection when assembling probe rods.



**SOP-GEOPROBE-07;
OPERATING THE GEOPROBE®
DURING PROBING OPERATIONS**

STATUS: DRAFT
DATE ISSUED:
11/16/2020
REVISION: 1
PAGE 10 of 16

NOISE	Elevated noise levels.	Geoprobe®.	Employees could be exposed to elevated noise levels when operating the Geoprobe® resulting in irritability, decreased concentration, and noise-induced hearing loss.	Personnel within a 20-foot buffer zone of the Geoprobe® will wear single hearing protection (e.g. earmuffs or earplugs). Non-essential personnel will maintain a 20-foot buffer zone around the Geoprobe®.
ELECTRICAL	<p>Defective electrical lines.</p> <p>Contact with overhead utilities.</p> <p>Contact with underground utilities.</p>	<p>Geoprobe®.</p> <p>Probing location.</p> <p>Probing location.</p>	<p>Contact with defective electrical lines could result in personal injury.</p> <p>Injury, death, or property damage could occur from contact with overhead utilities when the hammer assembly is raised to its highest position.</p> <p>Injury, death or property damage could occur from contact with underground utilities when geoprobing.</p>	<p>Inspect electrical lines of the Geoprobe® prior to and at the completion of the task.</p> <p>If overhead hazards are present, established overhead utility procedures will be followed. Probe locations will be moved to avoid working around overhead utilities. Employees will maintain the required minimal radial clearance distances based on voltage when working around overhead lines.</p> <p>Prior to starting work, employees will call for a utility locate (i.e., call 811). If underground utilities are present, established underground utility procedures will be followed. Probe locations will be moved to avoid working around underground utilities.</p>
BODY MECHANICS	Lifting and moving rods.	Probing location.	Employees could be exposed to back or muscle strains or sprains when lifting or connecting the Geoprobe® rods.	Employees will follow good lifting techniques including lifting with the legs and not the back, get a good grip, and keep the load close to your body. Two employees will lift the rods if necessary.



**SOP-GEOPROBE-07;
OPERATING THE GEOPROBE®
DURING PROBING OPERATIONS**

STATUS: DRAFT
DATE ISSUED:
11/16/2020
REVISION: 1
PAGE 11 of 16

GRAVITY	<p>Falls from slips and trips.</p> <p>Falling rods.</p>	<p>Uneven terrain, slick/muddy/wet surfaces and steep slopes.</p> <p>Probing location.</p>	<p>Walking on slick/muddy/wet and uneven terrain could cause slips and trips resulting in falls and injuries.</p> <p>Heavy rods could slip off of worker's hands while carrying and assembling tool strings causing personal injury.</p>	<p>Workers will wear work boots with good traction and ankle support. Employees will plan their path and walk cautiously. Keep work area free of tools/rods. If conditions are wet/muddy, muck boots may be worn. Site can be cleared of snow, if applicable. Employees will use work gloves when assembling and handling rods. Two workers will carry rods, if necessary. All personnel will wear steel-toe boots.</p>
WEATHER	<p>Cold/heat stress</p> <p>Lightning.</p>	<p>Outdoors.</p> <p>Sites.</p>	<p>Exposure to cold climates may result in cold burns, frostbites, and hypothermia. Exposure to high temperatures may result in heat cramps, heat exhaustion, or heat stroke.</p> <p>Electrocution, injury, death, or equipment damage could be caused by lightning strike.</p>	<p>Training on signs and symptoms of cold/heat stress is required. Personnel will wear appropriate clothing when working outdoors (e.g. layers). Employees will remain hydrated and will have sufficient caloric intakes during the day. Personnel will follow procedures outlined in applicable SSHASP and/or Pioneer corporate HASP.</p> <p>Employees will follow the 30/30 rule during lightning storms. When the Geoprobe® is running, the Geoprobe helper will watch/listen for lightning and thunder.</p>
RADIATION	<p>Ultraviolet (UV) radiation.</p>	<p>Outdoors.</p>	<p>Employees could be exposed to UV radiation during summer months causing sun burns, skin damage, and eye damage</p>	<p>Employees will wear sunscreen, long-sleeve work shirts and long pants. Employees will also use safety glasses with tinted lenses.</p>



**SOP-GEOPROBE-07;
OPERATING THE GEOPROBE®
DURING PROBING OPERATIONS**

STATUS: DRAFT
DATE ISSUED:
11/16/2020
REVISION: 1
PAGE 12 of 16

BIOLOGICAL	Inexperienced and improperly trained worker.	Sites.	Inexperienced workers and improper training could cause incidents resulting in adverse health effects and/or property damage.	Employees will be properly trained in this procedure and other applicable procedures. All employees operating the Geoprobe® will be familiar with the basic controls of the machine including the Emergency Kill switch button.
	Plants, insects, and animals.	Sites.	Exposure to plants, insects, and/or animals may cause rashes, blisters, redness, and swelling.	Training on the signs and symptoms of exposure to plants, insects, and animals. Avoid contact with plants, insects, and animals. First-aid kits will be available on site. Employees with allergies should notify their supervisor.
MECHANICAL	Geoprobe® shifting.	Probing location, when probing with percussion and working on a sloped surface.	Personal injury and equipment damage could occur if the Geoprobe® shifts while probing with percussion and when working on a sloped surface.	When probing with percussion, do not raise the machine foot more than approximately 6 inches off the ground or the vehicle may become unstable and shift. When working on a sloped surface, position the rig so that it is facing upslope. In the event that the probe unit loses stability, it will roll away from the operator without causing injury.
	Struck by the Geoprobe®.	Operating the Geoprobe®.	Personnel could be injured if struck by the Geoprobe®.	Non-essential personnel will maintain a 20-foot buffer zone around the rig.
	Improper body mechanics.	Assembling, handling, and retrieving rods/sample tubes.	Improper lifting, bending, squatting, and kneeling could result in muscle/back strains or other	Personnel will use proper lifting techniques – get a good grip, keep the load close to the body, lift with legs and not with back, and avoid lifting loads above shoulder height. Two people will lift, if



**SOP-GEOPROBE-07;
OPERATING THE GEOPROBE®
DURING PROBING OPERATIONS**

**STATUS: DRAFT
DATE ISSUED:
11/16/2020
REVISION: 1
PAGE 13 of 16**

	<p>Contact with rotating and moving parts of the Geoprobe®.</p>	<p>Operating the Geoprobe®.</p>	<p>injuries.</p> <p>Fingers/hands could become pinched or caught in moving/rotating parts of the Geoprobe® resulting in cuts, scrapes, and/or broken bones.</p>	<p>necessary.</p> <p>Employees will also use good body mechanics when retrieving rods/sample tubes: bend knees, lean slightly away from the object, keep back and wrists straight, use legs to move the objects.</p> <p>Employees should stretch prior to starting work and they will take breaks when necessary.</p> <p>Employees will not touch moving/rotating parts of the rig. Personnel will tie back long hair and will not wear loose clothing when operating the machine. Work gloves are required when operating the rig.</p> <p>Operators will stand to the control side of the machine, clear of the probe foot and derrick, while operating the controls. Personnel will never reach across the probe assembly to manipulate the machine controls.</p> <p>All employees on site will be familiar with the basic controls of the machine including the Emergency Kill switch button.</p> <p>Employees will always wear work gloves when operating the Geoprobe® and handling its components. Employees will never place their hands-on top of the tool string while raising or lowering the hammer. Workers will not place thumb or fingers between latch and hammer when raising</p>
	<p>Pinch points.</p>	<p>During equipment assembly, advancing the Geoprobe®, and extracting probe rods.</p>	<p>Employees could be exposed to hand injuries such as lacerations, punctures, cuts, and pinched fingers when assembling probe rods and sample</p>	



**SOP-GEOPROBE-07;
OPERATING THE GEOPROBE®
DURING PROBING OPERATIONS**

STATUS: DRAFT
DATE ISSUED:
11/16/2020
REVISION: 1
PAGE 14 of 16

	Flying debris.	Probing location.	casings, pulling probe rods and sampling devices with the hammer latch and/or the rod grip pull assembly, and when the Geoprobe hammer is in motion. Eye injuries could result from flying debris when driving tool strings into the ground.	latch to pull probe rods and sampling devices from the ground. Grind or file sharp burrs that can be developed on the outside of probe rods if the rod grip puller is allowed to slip during tool retrieval. Employees will wear safety glasses at all times during Geoprobe® operations.
PRESSURE	Pressurized hydraulic lines.	Geoprobe®.	Faulty pressurized hydraulic lines could burst resulting in personal injury/exposure and hydraulic fluid release.	All components of the rig will be inspected prior to and at the completion of the task.
THERMAL	Contact with hot drive head and caps.	Probing location.	The drive head and caps can become hot during probing operations and direct contact with these components could cause skin injuries.	Employees will let the drive head and caps cool down before removing them from the tool string. Workers will also wear work gloves when handling these components.
HUMAN FACTORS	Inexperience and improperly trained worker.	Sites.	Inexperience workers and improper training could cause incidents resulting in personal injuries and/or property damage.	Employees will be properly trained in his procedure and other applicable procedures. When starting/stopping for the first time, an experienced operator should be on site to help coach the process. All employees operating the Geoprobe® will be familiar with the basic controls of the



**SOP-GEOPROBE-07;
OPERATING THE GEOPROBE®
DURING PROBING OPERATIONS**

STATUS: DRAFT
DATE ISSUED:
11/16/2020
REVISION: 1
PAGE 15 of 16

				machine including the Emergency kill switch button. Employees will implement stop work procedures, if necessary.
SIMOPS	Not applicable.			

ADDITIONAL HSSE CONSIDERATIONS

This section to be completed with concurrence from the Safety and Health Manager.

REQUIRED PPE	Level D PPE, earplugs, and earmuffs.
APPLICABLE SDS	SDSs will be maintained based on site characterization and contaminants. Hydraulic fluid, diesel, and lubricating grease.
REQUIRED PERMITS/FORMS	Per site/project requirements.
ADDITIONAL TRAINING	Per site/project requirements.

DRAWINGS, DOCUMENTS, AND TOOLS/EQUIPMENT

The following documents should be referenced to assist in completing the associated task.

P&IDS	
DRAWINGS	
RELATED SOPs/PROCEDURES/WORK PLANS	SOP-GEOPROBE-04 Driving and Positioning the Geoprobe® Model 7822DT SOP-GEOPROBE-05 Geoprobe® DT-22 Dual Tube Sampling System SOP-GEOPROBE-06 Geoprobe® DT-325/375 Dual Tube Sampling System
TOOLS	
FORMS/CHECKLIST	

APPROVALS/CONCURRENCE

By signing this document, all parties acknowledge the completeness and applicability of this SOP for its intended purpose. Also, by signing this document, it serves as acknowledgement that I have received training on the procedure and associated competency testing.

SOP TECHNICAL AUTHOR	DATE
SAFETY AND HEALTH MANAGER	DATE



**SOP-GEOPROBE-07;
OPERATING THE GEOPROBE®
DURING PROBING OPERATIONS**

**STATUS: DRAFT
DATE ISSUED:
11/16/2020
REVISION: 1
PAGE 16 of 16**

APPROVALS/CONCURRENCE

By signing this document, all parties acknowledge the completeness and applicability of this SOP for its intended purpose. Also, by signing this document, it serves as acknowledgement that I have received training on the procedure and associated competency testing.

--	--

Revisions:

Revision	Description	Date
1	Updates to SOP to reflect Geoprobe ® Model 7822DT	11/16/2020



**PTS-SOP-GEOPROBE-08;
 GEOPROBE 0.5-IN. X 1.4-IN. OD AND
 0.75-IN. X 1.4-IN. OD PREPACKED
 SCREEN MONITORING WELLS**

STATUS: IN PROGRESS
DATE ISSUED: 11/05/13
REVISION: 0
PAGE 1 of 37

PURPOSE	<p>The purpose of this SOP is to provide instructions to install a permanent, small-diameter groundwater monitoring well that can be used to collect water quality samples, conduct hydrologic and pressure measurements, or perform any other sampling event that does not require large amounts of water over a short period of time (e.g., flow rate > 1 liter/minute). These methods meet or exceed the specifications discussed for direct push installation of permanent monitoring wells with prepacked screens in the U.S. Environmental Protection Agency’s guidance document, <i>Expedited Site Assessment Tools For Underground Storage Tank Sites</i>, (EPA, 1997) and ASTM Standards <i>D 6724</i> (ASTM, 2002) and <i>D 6725</i> (ASTM, 2002).</p>
SCOPE	<p>This practice has been prepared for the Pioneer Technical Services, Inc. (Pioneer) workforce and applies to work carried out by and on behalf of Pioneer. All members of the Pioneer workforce who conduct the work shall be trained and competent in the risk-assessed work described below.</p>
DEFINITIONS	<p>Geoprobe® Direct Push Machine: a vehicle-mounted, hydraulically-powered machine that uses static force and percussion to advance small-diameter sampling tools into the subsurface for collecting soil core, soil gas, or ground water samples. The Geoprobe® brand name refers to both machines and tools manufactured by Geoprobe Systems®, Salina, Kansas. Geoprobe® tools are used to perform soil core and soil gas sampling, groundwater sampling, soil conductivity and contaminant logging, grouting, materials injection, and to install small-diameter permanent monitoring wells or temporary piezometers.</p> <p>0.5-inch x 1.4-inch OD Prepacked Well Screen (0.5-inch prepack): an assembly consisting of a slotted PVC pipe surrounded by environmental grade sand contained within a stainless steel wire mesh cylinder. The inner component of the prepacked screen is a flush-threaded, 0.5-inch Schedule 80 PVC pipe with 0.01-inch (0.25 mm) slots. Stainless steel wire mesh with a pore size of 0.011 inches (0.28 mm) makes up the outer component of the prepack. The space between the inner slotted pipe and outer wire mesh is filled with 20/40 mesh silica sand. Geoprobe® 0.5-inch x 1.4-inch prepacks are available in 3-foot and 5-foot sections and have an outside diameter of 1.4 inches (36 mm) and a nominal inside diameter of 0.5 inches (13 mm).</p> <p>0.75-inch x 1.4-inch OD Prepacked Well Screen (0.75-inch prepack): an assembly consisting of a slotted PVC pipe surrounded by environmental grade sand contained within a stainless steel wire mesh cylinder. The inner component of the prepacked screen is a flush-threaded, 0.75-inch Schedule 40 PVC pipe with 0.01-inch (0.25 mm) slots. Stainless steel wire mesh with a pore size of 0.011 inches (0.28 mm) makes up the outer component of the prepack. The space between the inner slotted pipe and outer wire mesh is filled with 20/40 mesh silica sand. Geoprobe 0.75-inch x 1.4-inch prepacks are available in 3-foot and 5-foot sections and have an outside diameter of 1.4 inches (36 mm) and a nominal inside diameter of 0.75 inches (19 mm).</p>



**PTS-SOP-GEOPROBE-08;
GEOPROBE 0.5-IN. X 1.4-IN. OD AND
0.75-IN. X 1.4-IN. OD PREPACKED
SCREEN MONITORING WELLS**

STATUS: IN PROGRESS
DATE ISSUED: 11/05/13
REVISION: 0
PAGE 2 of 37

DISCUSSION

Conventional monitoring wells are typically constructed through hollow stem augers by lowering slotted PVC pipe (screen) to depth on the leading end of a string of threaded PVC riser pipe. A filter pack is then installed by pouring clean sand of known particle size through the tool string annulus until the slotted section of the PVC pipe is sufficiently covered.

Installing the entire filter pack through the tool string annulus becomes a delicate and time-consuming process when performed with small-diameter direct push tooling. Sand must be poured very slowly in order to avoid bridging between the riser pipe and probe rod. When bridging does occur, considerable time can be lost in attempting to dislodge the sand or possibly pulling the tool string and starting over.

Prepacked screens decrease the volume of loose sand required for well installation as each screen assembly includes the necessary sand filter pack. Sand must still be delivered through the casing annulus to provide a minimum 2-foot grout barrier, but this volume is significantly less than for the entire screened interval.

The procedures outlined in this document describe construction of a permanent groundwater monitoring well using Geoprobe® 2.125-inch (54 mm) outside diameter (OD) probe rods and 1.4-inch OD prepacked screens. Geoprobe® 1.4-inch prepacks are available with either nominal 0.5-inch schedule 80 or 0.75-inch schedule 40 PVC components. Further options include running lengths of 3 and 5 feet for both 0.5- and 0.75-inch prepacks.

Installation of a prepack monitoring well begins by advancing 2.125-inch (54 mm) outside diameter (OD) probe rods to depth with a Geoprobe® direct push machine. Prepacked screen(s) are then assembled and installed through the 1.5-inch (38 mm) inside diameter (ID) of the probe rods using corresponding 0.5-inch schedule 80 or 0.75-inch schedule 40 PVC riser (Fig. 2.1-A).

The prepack tool string is attached to an expandable anchor point with a locking connector that is threaded to the bottom of the leading screen. Once the connector is locked onto the anchor point, the rod string is slowly retracted until the lower end of the rods is approximately 3 feet above the top prepack.

Regulations generally require a minimum 2-foot grout barrier above the top prepack (Fig. 2.1-B) to avoid contaminating the well screens with bentonite or cement during installation. In some instances, natural formation collapse will provide the required barrier. If the formation is stable and does not collapse around the riser as the rod string is retracted, environmental grade 20/40 mesh sand may be installed through the probe rods to provide the minimum 2-foot grout barrier.

Granular bentonite or bentonite slurry is then installed in the annulus to form a well seal (Fig. 2.1-B). A high-pressure grout pump (Geoprobe® Model GS1000 or GS500) may be used



**PTS-SOP-GEOPROBE-08;
GEOPROBE 0.5-IN. X 1.4-IN. OD AND
0.75-IN. X 1.4-IN. OD PREPACKED
SCREEN MONITORING WELLS**

STATUS: IN PROGRESS
DATE ISSUED: 11/05/13
REVISION: 0
PAGE 3 of 37

to tremie high-solids bentonite slurry or neat cement grout to fill the well annulus as the probe rods are retracted (Fig. 2.1-B). The grout mixture must be installed with a tremie tube from the bottom up to accomplish a tight seal without voids to meet regulatory requirements.

In certain formation conditions, the prepacked screens may bind inside the probe rods as the rods are retracted. This is most common in sandy formations sometimes called flowing or heaving sands. This binding can generally be overcome by lowering extension rods down the inside of the well riser and gently, but firmly, tapping the extension rods against the base of the well as the rods are slowly retracted. If the binding persists, clean tap water or distilled water may be poured down the annulus of the rods to increase the hydraulic head inside the well. This, combined with the use of the extension rods, will free up the prepacked screen and allow for proper emplacement.

Once the well is set, conventional flush-mount or aboveground well protection can be installed to prevent tampering or damage to the well head (Fig. 2.1-B). These wells can be sampled by several available methods (bladder pump, peristaltic pump, mini-bailer, Geoprobe® tubing check valve, etc.) to obtain high integrity water quality samples. These wells also provide accurate water level measurements and can be used as observation wells during aquifer pump tests.

When installed properly, these small-diameter wells generally meet regulatory requirements for a permanent monitoring well. While a detailed installation procedure is given in this document, it is by no means totally inclusive. **Always check local regulatory requirements and modify the well installation procedure accordingly.** These methods meet or exceed the specifications discussed for direct push installation of permanent monitoring wells with prepacked screens in the U.S. Environmental Protection Agency's guidance document, *Expedited Site Assessment Tools For Underground Storage Tank Sites*, (EPA, 1997) and ASTM Standards D 6724 (ASTM, 2002) and D 6725 (ASTM, 2002).

WORK INSTRUCTIONS

The following instructions are intended to provide sufficient guidance to perform the task in a safe, accurate, and reliable manner. Should these instructions present information that is inaccurate or unsafe, operations personnel must bring the issue to the attention of the Project Manager and the appropriate revisions made. All work carried under this SOP will be consistent with procedures and policies described in the appropriate Operation, Maintenance, and Monitoring (O&M) Plan (where applicable), appropriate Site Specific Health and Safety Plan (SSHASP), and Pioneer Corporate Health and Safety Plan (HASP).

TASK	INSTRUCTIONS
Anchoring the Well Assembly	In this portion of the well installation procedure, an expandable anchor point is driven to depth on the end of a 2.125-inch (54 mm) OD probe rod string (Fig. 4.1). A prepacked screen assembly is inserted into the I.D. of the rod string with 5-foot (1.5 m) sections of PVC riser pipe (Fig. 4.2). The screens and riser pipe are attached to the



**PTS-SOP-GEOPROBE-08;
GEOPROBE 0.5-IN. X 1.4-IN. OD AND
0.75-IN. X 1.4-IN. OD PREPACKED
SCREEN MONITORING WELLS**

STATUS: IN PROGRESS
DATE ISSUED: 11/05/13
REVISION: 0
PAGE 4 of 37

anchor point via a snap-lock connector.

1. If the monitoring well is to have a flush-mount finish, it is a good practice to prepare a hole large enough to accept a standard well protector before driving the probe rods.
2. Move the Geoprobe® direct push machine into position over the proposed monitoring well location. Unfold the probe and place in the proper probing position as shown in the unit Owner's Manual. Access to the top of the probe rods will be required. It is therefore important to allow room for some derrick retraction when placing the unit in the probing position.
3. Referring to Figure 4.3, place an O-ring in the groove of a 2.125-inch Expendable Anchor Point (GW2040). Insert the point into the unthreaded end of a 2.125-inch Expendable Point Holder. Note that expendable point holders are available in lengths of 36 inches/0.9 meters (AT2110), 48 inches/1.2 meters (AT2111), or 60 inches/1.5 meters (AT2112).
4. Attach a 2.125-inch Drive Cap (AT2101) to the threaded end of the point holder (Fig. 4.3).
5. Place the extendable point holder under the probe hammer in the driving position (refer to unit Owner's Manual). Drive the point holder into the ground utilizing percussion if necessary. It is important that the rod string is driven as straight as possible to provide a plumb monitoring well. If the point holder is not straight, pull the assembly and start over with Step 2.
6. Remove the drive cap from the expendable point holder. Install an O-ring (AT2100R) on the point holder in the groove located at the base of the male threads (Fig. 4.4).

Note: the operator may choose to lubricate the O-ring with a small amount of clean water. Lubricating the O-ring makes it easier to thread the probe rods together and nearly eliminate torn O-rings. A small spray bottle works well for applying the water.

7. Thread a 2.125-inch Probe Rod (AT2136, AT2139, AT2148, or AT2160) onto the expendable point holder. Place the drive cap on the probe rod and advance the rod string.
8. Remove the drive cap and install an O-ring (AT2100R) at the base of the male threads of the probe rod (Fig. 4.4). Add another probe rod and replace the drive cap. Once again, advance the rod string.
9. Repeat Step 8 until the end of the rod string is 4 inches (102 mm) below the



**PTS-SOP-GEOPROBE-08;
GEOPROBE 0.5-IN. X 1.4-IN. OD AND
0.75-IN. X 1.4-IN. OD PREPACKED
SCREEN MONITORING WELLS**

STATUS: IN PROGRESS
DATE ISSUED: 11/05/13
REVISION: 0
PAGE 5 of 37

bottom of the desired screen interval. The additional depth allows for the connection between the expendable anchor point and screen assembly. The top probe rod must also extend at least 1 foot (25 mm) above the ground surface to allow room for the rod grip puller later in this procedure. Move the probe foot back to provide access to the top of the rod string.

10. With the probe rods and anchor point drive to the proper depth, the next step is to deploy the screen(s) and riser pipe. Thread together 1.4-inch OD prepack sections to achieve the desired screen interval. As shown in Figure 4.5, 1.4-inch OD prepacks are available with 0.5-inch Schedule 80 PVC or 0.75-inch Schedule 40 PVC components and in lengths of 3 or 5 feet (0.9 or 1.5 m). O-rings (GW430R) can be installed between the screen sections if desired.
11. Thread a Snap-look Connector (0.5-inch, GW2030 or 0.75-inch 17469) into the female end of the assembled prepacks (Fig. 4.5). An O-ring can be placed on the male threads of the connector if desired.
12. Insert the screen assembly into the probe rod string with the connector facing toward the bottom of the rod as shown in Figure 4.2.
13. With the assistance of a second person, attach 5-foot (1.5 m) sections of 0.5-inch Schedule 80 or 0.75-inch Schedule 40 PVC Riser (GW2050 or 11747) to the top of the screen assembly. O-rings are required at each riser joint to prevent groundwater from seeping into the well from above the desired monitoring interval. Continue adding riser sections until the assembly reaches the bottom on the rods (Fig. 4.2). At least 1 foot (0.3 m) of riser should extend past the top probe rod.
14. Install a PVC top cap or locking well plug on the top riser (Figure 4.5). If using the vinyl cap, secure the cap with two wraps of duct tape or electrical tape.
15. Raise the screen and riser assembly a few inches and then quickly lower it onto the expendable anchor point. This should force the snap-lock connector over the mushroomed tip of the anchor (Fig. 4.6). Gently pull up the riser to ensure that the connector and anchor are firmly attached. Approximately 0.25 inches (6 mm) of play is normal.
16. It is now time to pull up the probe rods from around the well screen and riser. Reposition the probe unit so that the Rod Grip Puller can be attached to the rod string.
17. Retract the rod string the length of the screens plus an additional 3 feet (1 m). While pulling the rods, observe whether the PVC risers stay in place or move up with the rods.



**PTS-SOP-GEOPROBE-08;
 GEOPROBE 0.5-IN. X 1.4-IN. OD AND
 0.75-IN. X 1.4-IN. OD PREPACKED
 SCREEN MONITORING WELLS**

STATUS: IN PROGRESS
DATE ISSUED: 11/05/13
REVISION: 0
PAGE 6 of 37

	<ol style="list-style-type: none"> a. If the risers stay in place, stable formation conditions are present. Continue retracting the rods to the depth specified above. Go to Section "Sand Pack and Grout Barrier." b. If the risers move up with the probe rods, have a second person hold it in place while putting up the rods. An additional section of PVC riser may be helpful. Once the probe rods have cleared the anchor point and part of the screen, the screen and riser assembly should stop raising with the rods. Continue retracting to the depth specified above. Go to Section "Sand Pack and Grout Barrier." c. If the risers continue to move up with the probe rods and cannot be held in place by hand, the anchor point is most likely located in heaving sands. Extension rods are now required. (Refer to Figure 4.6 for an illustration of extension rod accessories.) d. Place a Screen Push Adapter (GW 1535) on the end of an Extension Rod. Insert the adapter and extension rod into the PVC riser and hold by hand or with an Extension Rod Jig (AT690). Attach additional extension rods with Extension Rod Couplers (AT68) or Extension Rod Quick Links (AT694K) until the push adapter contacts the bottom of the screens (Fig. 4.8). Place an Extension Rod Handle (AT69) on the top extension rod after leaving 3 to 4 feet (1 to 1.2 m) of extra height above the last probe rod. e. Slowly retract the probe rods while another person pushes and taps on the screen bottom with the extension rods (Fig. 4.8). To ensure proper placement of the screen interval and prevent damage to the well, be careful not to get ahead while pulling the probe rods. The risers should stay in place once the probe rods are withdrawn past the screens. Retrieve the extension rods. Place the cap back on the top riser and secure the cap with duct tape if necessary.
<p>Sand Pack and Grout Barrier</p>	<p>The natural formation will sometimes collapse around the well screens as the probe rod string is withdrawn. This provides an effective barrier between the screens and grout material used to seal the well annulus. If the formation does not collapse, a sand barrier must be placed from the surface. This portion of the well installation procedure is important because an inadequate barrier will allow grout to reach the well screens. Nonrepresentative samples and retarded groundwater flow into the well may result from grout intrusion.</p> <ol style="list-style-type: none"> 1. Using a Water Level Sounder (GW 1200) or flat tape measure, determine the depth from the top of the PVC riser to the bottom of the annulus between the riser and probe rods. Two scenarios are possible: <ol style="list-style-type: none"> a. Measured depth is 2 to 3 feet (0.6 to 0.9 m) less than riser length. This indicates that unstable conditions have resulted in formation collapse. A



**PTS-SOP-GEOPROBE-08;
GEOPROBE 0.5-IN. X 1.4-IN. OD AND
0.75-IN. X 1.4-IN. OD PREPACKED
SCREEN MONITORING WELLS**

STATUS: IN PROGRESS
DATE ISSUED: 11/05/13
REVISION: 0
PAGE 7 of 37

natural grout barrier has formed as material collapsed around the PVC riser when the probe rods were retracted. This commonly occurs in heaving sands. No further action is required. Proceed to Section "Bentonite Seal Above Screen" and perform Step 2 (for unstable formations).

- b. Measured depth is equal to or greater than riser length. This indicates that stable conditions are present and the cohesive formation did not collapse. The probe hole has remained open and void space exists between the riser (and possibly the screen) and formation material. Clean sand must be placed downhole to provide a suitable grout barrier. Continue with Step 2 below.

2. Begin slowly pouring 20/40 mesh sand down the annulus between the PVC riser and probe rod string. Reduce spillage by using a funnel or flexible container as shown in Figure 4.8. Add approximately 2.0 liters of sand for each 3-foot (1 m) screen section or 3.25 liters of sand for each 5-foot (1.5 m) screen, plus 1.75 – 2.0 liters for a minimum 2-foot (0.6 m) layer of sand above the top screen section.

Note: the sand volumes specified above assume maximum annular space where no formation collapse has occurred. Actual volumes may be less in field conditions.

3. Measure the annulus depth after each 1.0 – 1.5 liters of sand. The sand may not fall all the way past the screens due to the tight annulus and possible water intrusion. This is acceptable, however, since the prepacked screens do not require the addition of sand. The important thing is that a sand barrier is provided above the screens.
4. Sand may also bridge within the annulus between the risers and probe rods and consequently fail to reach total depth (Fig. 4.9). This most likely occurs when the sand contacts the water inside the probe rods during well installations below the water table. Wet probe rods also contribute to sand bridging. If the annulus is open, skip to Section "Bentonite Seal Above Screen," Step 1. If bridging is evident, continue with Step 5 below.
5. In case of a sand bridge above the screens (wet rods, high water table, etc.), insert clean extension rods into the well annulus to break up the sand (Fig. 4.9). Simultaneously retracting the probe rods usually helps. Check annulus depth again. If sand is no longer bridged, proceed to Section "Bentonite Seal Above Screen." If bridging is still evident, continue with Step 6 below.
6. If the sand bridge cannot be broken up with extension rods, inject a small amount of clean water into the annulus. This is accomplished with a Geoprobe® Model GS1000 or GS500 Grout Machine and 3/8-inch (9.5 mm) OD nylon tubing



**PTS-SOP-GEOPROBE-08;
GEOPROBE 0.5-IN. X 1.4-IN. OD AND
0.75-IN. X 1.4-IN. OD PREPACKED
SCREEN MONITORING WELLS**

STATUS: IN PROGRESS
DATE ISSUED: 11/05/13
REVISION: 0
PAGE 8 of 37

	<p>(11633). Simply insert the nylon tubing down the well annulus until the sand bridge is contacted. Attach the tubing to the grout machine and pump up to one gallon of clean water while moving the tubing up and down. The jetting action of the water will loosen and remove the sand bridge. Check annulus depth again. The distance should be 2 to 3 feet (0.6 to 0.9 m) less than the riser length when the sand barrier is completed. Proceed with Section "Bentonite Seal Above Screen."</p>
<p>Bentonite Seal Above Screen</p>	<p>Bentonite is a clay material which exhibits very low permeability when hydrated. When properly placed, bentonite can prevent contaminants from moving into the well screens from above the desired monitoring interval. The seal is formed either by pouring granular bentonite into the annulus from the ground surface, or by injecting a high-solids bentonite slurry directly above the grout barrier. The use of bentonite chips is limited to cases in which the top of the screen ends above the water table (no water is present in the probe rods). Whichever method is used, at least 2 feet (0.6 m) of bentonite must be placed above the sand pack.</p> <p>1. (Stable Formation) Granular bentonite is recommended if the following conditions are met:</p> <ul style="list-style-type: none"> i. Top of screen interval is above the water table. ii. Formation remained open when probe rods were retracted. iii. Bridging was not encountered while installing the sand pack and grout barrier in Section "Sand Pack and Grout Barrier." <ul style="list-style-type: none"> a. Withdraw the probe rod string another 3 to 4 feet (0.9 to 1 m) and ensure that the PVC riser does not rise with rods. It is important that the bottom of the rod string is above the proposed seal interval. If positioned too low, dry bentonite will backup into the expendable point holder. Bridging then results if moisture is present inside the probe rods. b. Pour approximately 1.5 liters of granular bentonite between the probe rods and PVC riser as was done with the sand in Section "Sand Pack and Grout Barrier." c. Measure the riser depth to the bottom of the annulus. The distance should now equal the installed riser length minus the minimum 2 feet (0.6 m) of sand pack and 2 feet (0.6 m) of bentonite seal. As was stated with the sand pack, if the measured depth is significantly less than expected, the bentonite has more than likely bridged somewhere along the rod string. A procedure similar to that identified for bridged sand (Section "Sand Pack and Grout Barrier," Steps 5 and 6) may be utilized to dislodge the granular bentonite. d. Once it has been determined that the bentonite seal is properly emplaced, add 1 liter of clean water to hydrate the dry bentonite according to regulations. This is not necessary if water was used to clear



**PTS-SOP-GEOPROBE-08;
GEOPROBE 0.5-IN. X 1.4-IN. OD AND
0.75-IN. X 1.4-IN. OD PREPACKED
SCREEN MONITORING WELLS**

STATUS: IN PROGRESS
DATE ISSUED: 11/05/13
REVISION: 0
PAGE 9 of 37

	<p style="text-align: center;">bridged bentonite.</p> <p>2. (Unstable Formation) A grout machine is required to install the bentonite seal if the formation collapsed when the rods were retracted or the sand bridged when installing the grout barrier. The pump is able to supply a high-solids bentonite slurry under sufficient pressure to displace formation fluids. Void spaces often develop when poured (gravity installed) granular bentonite is used under these conditions, resulting in an inadequate annular seal. Wet rods will often lead to bridging problems as well.</p> <ol style="list-style-type: none"> a. Mix 1 gallon (3.8 L) of high-solids bentonite (20 to 25 percent by dry weight) and place in the hopper of the grout machine. b. Insert 3/8-inch nylon tubing (see note below) to the bottom of the annulus between the probe rods and well riser. Leaving at least 15 feet (5 m) extending from the top of the rod string, connect the tubing to the grout machine. This extra length will allow rod extraction later in the procedure. <p><u>Note:</u> the side-port tremie method is recommended to prevent intrusion of grout into the sand barrier. To accomplish side-port discharge of grout, cut a notch approximately one inch up from the leading end of the tubing and then close the leading end with a threaded plug of suitable size.</p> <ol style="list-style-type: none"> c. Activate the grout pump and fill the tremie tube with bentonite. Begin slowly pulling the rod string approximately 3 feet (1 m) while operating the pump (Fig. 4.10). This will place bentonite in the void left by the retracted rods before it is filled by the collapsing formation. Continue to watch that the PVC riser does not come up with the rod string. When removing the retracted probe rod, slide the rod over the nylon tubing and place it on the ground next to the grout machine. This eliminates cutting and reattaching the tubing for each rod removed from the string. Take care not to “kink” the tubing during this process as it will create a weak spot in the tubing which may burst when pressure is applied. d. Measure the annulus depth to ensure that at least 2 feet (0.6 m) of bentonite was delivered. Pump additional bentonite slurry if needed.
<p>Grouting Well Annulus</p>	<p>The placement of grout material within the remaining well annulus provides additional protection from vertical contaminant migration. Most grout mixes are composed of neat cement, high-solids bentonite slurry, or a combination of cement and bentonite. Such mixes must be delivered with a high-pressure grout pump. When stable formations exist, the well may be sealed by pouring dry granular bentonite directly into the annulus from the ground surface. Consult the appropriate regulatory agency to determine approved grouting methods.</p>



**PTS-SOP-GEOPROBE-08;
GEOPROBE 0.5-IN. X 1.4-IN. OD AND
0.75-IN. X 1.4-IN. OD PREPACKED
SCREEN MONITORING WELLS**

STATUS: IN PROGRESS
DATE ISSUED: 11/05/13
REVISION: 0
PAGE 10 of 37

This section presents the procedure for grouting the well annulus with the Geoprobe® Model GS1000 or GS500 Grout Machines. Refer to Figure 4.11 as needed.

1. Mix an appropriate amount of grout material and place it in the hopper on the grout machine. (Refer to the Geoprobe® Yellow Field Book for tables on volume requirements.)

Note: it is recommended that an additional 25 to 30 percent of the calculated annulus volume is included in the total grout volume. This allows for material that is left in the grout hose and tubing or moves into the formation during pumping. An approximate range is 0.25 to 0.30 gallons (0.9 to 1.1 L) of grout for each foot of riser below ground surface.

2. A side-port tremie tube may be made from a roll of 3/8-inch OD Nylon Tubing (11633) by cutting a notch in the side of the tubing approximately 1 inch (25 mm) up from the discharge end. Thread a bolt or screw of suitable diameter into the end of the tubing so that pumped grout is forced out through the notch in a side-discharge manner.

Insert the side-port tremie tube into the well annulus until the leading end of the tube reaches the top of the bentonite seal. At least 15 feet (5 m) of tubing should extend from the top of the rod string. This extra length allows rod extraction with the tubing attached to the pump.

3. Attach the tubing to the grout machine and begin pumping. If the bentonite seal was below the water table (deep well installation), water will be displaced and flow from the probe rods as the annulus is filled with grout. Continue operating the pump until undiluted grout flows from the top probe rod.
4. Reposition the direct push machine and prepare to pull rods.
5. Begin pulling the probe rods while continuing to pump grout. Match the pulling speed to grout flow so that the rods remain filled to the ground surface. This maintains hydraulic head within the probe rods and ensures that the space left by the withdrawn rods is completely filled with grout.

Note: slide the probe rods over the nylon tubing and place neatly on the ground next to the grout machine. **Be careful not to pinch or bind the tubing as this forms weak spots which may burst when pressure is applied.**

Note: try to avoid filling the upper 12 inches (305 mm) of well annulus with grout when pulling the expendable point holder. This will make for cleaner well protector installation.



**PTS-SOP-GEOPROBE-08;
GEOPROBE 0.5-IN. X 1.4-IN. OD AND
0.75-IN. X 1.4-IN. OD PREPACKED
SCREEN MONITORING WELLS**

STATUS: IN PROGRESS
DATE ISSUED: 11/05/13
REVISION: 0
PAGE 11 of 37

	<p>6. When all probe rods have been retrieved and the well is adequately grouted, unstring the tremie tube and begin cleanup. It is important to promptly clean the probe rods, grout machine, and accessories. This is especially true of cement mixes as they quickly set up and are difficult to remove once dried.</p>
<p>Surface Cover/Well Protection</p>	<p>A surface cover protects the PVC well riser from damage and tampering. Although aboveground and flush-mount well covers may be used, most Geoprobe® prepack monitoring wells have been installed with flush-mount covers (Fig. 4.12). Consult the project planners and/or appropriate regulators to determine the approved well cover configuration for your specific application.</p> <ol style="list-style-type: none"> 1. In order to fit under a flush-mount cover, the top of the well riser must be below the ground surface. Place the well cover over the riser to mark the cover diameter. Remove the cover and excavate the soil around the well head to install the protector. 2. The top of the riser should be located several inches above the bottom of the hole (but below the adjacent ground surface) before installation of the well cover. If a riser joint is near this level, the operator may choose to unthread the top riser and adjust the depth of the hole to fit the riser height. Most prepack installations will instead require trimming the top riser to the appropriate height with PVC cutters. <p><u>Note:</u> do not cut off the riser with a hacksaw as cuttings may fall down into the screens.</p> <ol style="list-style-type: none"> 3. In most areas, regulations specify that a locking plug be installed on the top riser of permanent monitoring wells. Insert a locking well plug into the riser and tighten the hex bolt with a ½-inch T-handle wrench or nut driver until the cap fits snugly. 4. Position the well cover so that it is centered over the well riser. Provide at least 0.5 inches (13 mm) of space between the top of the locking plug and bottom of the well cover lid. If flush-mount protection is used, install the cover slightly above grade to prevent ponding of runoff water at the well head. 5. Support the well cover by installing a concrete pad according to project requirements. Pads are commonly square-shaped with a thickness of 4 inches (102 mm) and sides measuring 24 inches (610 mm) or greater. Finish the pad so that the edges slope away from the center to prevent ponding of surface water on the well cover. 6. Fill the inside of the well cover with sand up to approximately 2 to 3 inches (51



**PTS-SOP-GEOPROBE-08;
 GEOPROBE 0.5-IN. X 1.4-IN. OD AND
 0.75-IN. X 1.4-IN. OD PREPACKED
 SCREEN MONITORING WELLS**

STATUS: IN PROGRESS
 DATE ISSUED: 11/05/13
 REVISION: 0
 PAGE 12 of 37

	<p>to 76 mm) from the top of the riser and locking plug.</p>
<p>Well Development</p>	<p>“The development serves to remove the finer grained material from the well screen and filter pack that may otherwise interfere with water quality analyses, restore groundwater properties disturbed during the (probing) process, and to improve the hydraulic characteristics of the filter pack and hydraulic communication between the well and the hydrologic unit adjacent to the well screen.” (ASTM D 5092).</p> <p>The two most common methods of well development are bailing or pumping (purging) and mechanical surging.</p> <p>Purging involves removing at least three well volumes of water with either a Tubing Bottom Check Valve (GW42) or a Stainless Steel Mini-Bailer Assembly (GW41). Include the entire 2.125-inch (54 mm) diameter of disturbed soil at the screen interval when calculating the well volume.</p> <p>Mechanical Surging utilizes a surge block or swab which is attached to extension rods and lowered inside the riser to the screen interval. The extension rods and surge block are moved up and down, forcing water into and out of the screen. A tubing bottom check valve or peristaltic pump is then used to remove the water and loosened sediments (Figure 4.13).</p> <p>Note: mechanical surging may damage the well screen and/or reduce groundwater flow across the filter pack if performed incorrectly or under improper conditions. Refer to ASTM D 5521. “Standard Guide for Development of Groundwater Monitoring Wells in Granular Aquifers” for a detailed discussion of mechanical surging.</p> <p>Fine Grained Formations: many times field conditions or regulations require us to install monitoring wells in fine-grained formations that would not be considered a true aquifer. Development in these conditions is difficult at best. There are various development methods that may be useful depending on the specific grain size distribution of the formation. In formations with a good proportion of sand, using a rod brush slightly larger than the ID of the well as a swab may help in surging the well without clogging the filter pack. Caution is required. Adding water to slow-yielding wells may also help to loosen fines and improve recharge when swabbing. Purging wells in fine-grained formations with a peristaltic pump or bladder pump may offer the best means of development as high-energy surging can clog the screens. For more information on this topic request the Geoprobe® bulletin titled <i>Groundwater Quality and Turbidity vs. Low Flow</i>.</p> <p>Development should continue until representative water is obtained and natural flow is established into the well. Previously, representative water was defined primarily on the basis of consistent pH, specific conductance, temperature</p>



**PTS-SOP-GEOPROBE-08;
GEOPROBE 0.5-IN. X 1.4-IN. OD AND
0.75-IN. X 1.4-IN. OD PREPACKED
SCREEN MONITORING WELLS**

STATUS: IN PROGRESS
DATE ISSUED: 11/05/13
REVISION: 0
PAGE 13 of 37

	<p>measurements, and visual clarity (ASTM D 5092). To meet the more stringent requirements of the low-flow sampling protocol (EPA 1996), monitoring of additional parameters such as dissolved oxygen (DO) and oxidation/reduction potential (ORP or Eh), and quantitative measurement of turbidity may be required.</p>
<p style="text-align: center;">Sample Collection</p>	<p>As the federal EPA and more state agencies are recommending or requiring use of the “low-flow” sampling protocol (EPA 1996), the ability to sample small-diameter, direct push (DP) installed monitoring wells with bladders pumps has significantly increased. There are two Geoprobe® bladder pumps (Model A for ½” wells and Model B for ¾” or larger wells) available that permit low-flow sampling in the small-diameter DP installed monitoring wells. The low-flow sampling method is preferred when sampling for volatile contaminants or metal analytes. Both pumps can be used with any of the available flow-through-cells and water quality monitoring probes. Smaller volume flow-through-cells are recommended when available. Use of the bladder pump and flow-through-cell allows you to meet the stringent requirements for monitoring pH, specific conductance, DO, and ORP, and obtaining low-turbidity samples for metals analysis.</p> <p>Groundwater samples may be collected with a tubing bottom check valve (with 3/8-inch OD poly tubing as shown in Fig. 4.12) or a stainless steel mini-bailer assembly when appropriate. While the check valve is the quicker and more economical sampling device, some operators still prefer the traditional mini-bailer.</p> <p><u>Note:</u> the up and down motion of the check valve may introduce error when collecting samples for volatiles analysis. To avoid volatiles loss, lower the check valve and tubing to the target monitoring zone without the check ball. Drop the check ball to the bottom of the tubing from the ground surface. This seals the check valve and captures the sample inside the tubing without stripping away volatiles. To collect the sample, simply retrieve the tubing from the well riser, remove the check valve, and place the groundwater in an approved container.</p> <p>Before going into the field to sample monitoring wells (or groundwater samplers), be sure to know the level of sample quality that will be required. For high-integrity samples that must meet strict data quality objectives, sampling with a bladder pump may be required. Conversely, if screening level data is required (is it there and about how much?) bladder pumps will be slow and ineffective while the tubing check valve would be sufficient and save time and money. For more information on this topic, request the Geoprobe® bulletin titled <i>Groundwater Quality and Turbidity vs. Low Flow</i>.</p>
<p style="text-align: center;">Equipment Decontamination</p>	<p>Before and after each use, thoroughly clean all parts of the soil sampling system according to project requirements. A clean, new liner is recommended for each use. Parts should also be inspected for wear or damage at this time.</p>



**PTS-SOP-GEOPROBE-08;
 GEOPROBE 0.5-IN. X 1.4-IN. OD AND
 0.75-IN. X 1.4-IN. OD PREPACKED
 SCREEN MONITORING WELLS**

STATUS: IN PROGRESS
 DATE ISSUED: 11/05/13
 REVISION: 0
 PAGE 14 of 37

Personnel Decontamination	<p>1. All personnel must go through decontamination procedures whenever leaving a contaminated area. Decontamination procedures should be used in conjunction with methods to prevent contamination including minimizing contact with wastes and maximizing worker protection. Personnel must follow PTS-SOP-DE-01 Personnel Decontamination Procedures.</p>
--------------------------------------	--

HSE CONSIDERATIONS				
This section to be completed with concurrence from the Safety Officer.				
<i>SOURCE</i>	<i>HAZARDS</i>	<i>WHERE</i>	<i>HOW, WHEN, RESULT</i>	<i>CONTROLS</i>
CHEMICAL	<p>1. Contact with contaminated soils and underground water.</p> <p>2. Carbon Monoxide (CO).</p> <p>3. Hydraulic fluid.</p>	<p>1. Contaminated sites, during sample collection and handling.</p> <p>2. Vehicle and equipment.</p> <p>3. Testing sites, when using the Geoprobe.</p>	<p>1. Adverse health effects could result from ingesting, inhaling, and/or skin/eyes contact with contaminated soils and underground water.</p> <p>2. Potential exposure to CO when working around idling vehicles/equipment could result in irritated eyes, headache, nausea, weakness and dizziness.</p> <p>3. Employees could be exposed to hydraulic fluid via inhalation, ingestion, and skin/eyes contact when checking the hydraulic system of the machine or during spills/leaks resulting in adverse health</p>	<p>1. Personnel will practice proper personal hygiene – wash hands prior to eating and when leaving the site. Employees will wear nitrile gloves when collecting and handling samples. Work will be suspended during high wind conditions that produce large amounts of visible dust.</p> <p>2. Employees will minimize the time sitting in idling vehicles and will open a window to increase ventilation. Employees will avoid working around idling vehicles/equipment and stay up wind.</p> <p>3. Employees will prevent skin/eyes contact with hydraulic fluids and they will wear nitrile gloves and eye protection. In the event of a spill/leak, personnel will contain the fluid using the spill cleanup material available at the site. Cleanup materials will be disposed of according to the appropriate regulations. All components</p>



**PTS-SOP-GEOPROBE-08;
 GEOPROBE 0.5-IN. X 1.4-IN. OD AND
 0.75-IN. X 1.4-IN. OD PREPACKED
 SCREEN MONITORING WELLS**

STATUS: IN PROGRESS
DATE ISSUED: 11/05/13
REVISION: 0
PAGE 15 of 37

HSSE CONSIDERATIONS This section to be completed with concurrence from the Safety Officer.				
	4. Granular bentonite.	4. Testing sites.	<p>effects.</p> <p>4. Employees could be exposed to granular bentonite via inhalation, ingestion, and skin/eyes contact when sealing well screens resulting in adverse health effects.</p>	<p>of the Geoprobe will be inspected prior to and at the completion of the task. Non-essential personnel will maintain a 20-foot buffer zone around the equipment.</p> <p>4. Personnel will practice proper personal hygiene – wash hands prior to eating and when leaving the site. Employees will wear nitrile gloves and safety glasses when handling granular bentonite. Work will be suspended during high wind conditions that could produce large amounts of visible bentonite dust.</p>
	5. Silica sand.	5. Testing sites.	<p>5. Employees could be exposed to silica sand via inhalation, ingestion, skin/eyes contact when installing a grout/sand barrier for the well resulting in adverse health effects.</p>	<p>5. Personnel will practice proper personal hygiene – wash hands prior to eating and when leaving the site. Employees will wear nitrile gloves and safety glasses when handling silica sand. Work will be suspended during high wind conditions that could produce large amounts of visible silica dust.</p>
	6. Fresh concrete.	6. Testing sites.	<p>6. Employees could be exposed to fresh concrete when installing a concrete pad to support the well cover. Contact with fresh concrete may</p>	<p>6. Employees will wear work boots, gloves, and safety glasses when handling fresh concrete. Workers will also avoid direct contact with fresh concrete and prevent fresh concrete soak into clothing or rub against skin. Proper personal hygiene is</p>



**PTS-SOP-GEOPROBE-08;
 GEOPROBE 0.5-IN. X 1.4-IN. OD AND
 0.75-IN. X 1.4-IN. OD PREPACKED
 SCREEN MONITORING WELLS**

STATUS: IN PROGRESS
 DATE ISSUED: 11/05/13
 REVISION: 0
 PAGE 16 of 37

HSSE CONSIDERATIONS				
This section to be completed with concurrence from the Safety Officer.				
			result in irritation and/or chemical burns of eyes, skin, and nose. It may also cause dermatitis.	also required when handling fresh concrete.
PRESSURE	<p>1. Pressurized hydraulic lines.</p> <p>2. Pressurized lines from the high-pressure grout pump (Geoprobe® Model GS1000 or GS500).</p> <p>3. Excessive noise levels.</p>	<p>1. Testing sites.</p> <p>2. Testing sites.</p> <p>3. Testing sites.</p>	<p>1. Adverse health effects could result from faulty pressurized hydraulic lines.</p> <p>2. Adverse health effects could result from faulty pressurized lines if using the high-pressure grout pump to inject grout to the bottom of well screens.</p> <p>3. Employees could be exposed to excessive noise levels when operating the Geoprobe resulting in irritability, decreased concentration, and noise-induced hearing loss.</p>	<p>1. All components of the Geoprobe will be inspected prior to and at the completion of the task.</p> <p>2. All components of the high-pressure grout pump will be inspected prior to and at the completion of the task.</p> <p>3. Personnel operating the Geoprobe will wear double hearing protection (i.e., earplugs and earmuffs). Non-essential personnel will wear hearing protection (e.g., earplugs) and will maintain a 20-foot buffer zone around the Geoprobe when possible.</p>
ELECTRICAL	1. Lightning.	1. Outdoor sites.	1. Electrocutation, injury, death, or equipment damage could be caused by	1. Employees will follow the 30/30 rule during lightning storms.



**PTS-SOP-GEOPROBE-08;
 GEOPROBE 0.5-IN. X 1.4-IN. OD AND
 0.75-IN. X 1.4-IN. OD PREPACKED
 SCREEN MONITORING WELLS**

STATUS: IN PROGRESS
DATE ISSUED: 11/05/13
REVISION: 0
PAGE 17 of 37

HSSE CONSIDERATIONS				
This section to be completed with concurrence from the Safety Officer.				
	2. Contact with overhead utilities.	2. Testing sites.	lightning strike. 2. Injury, death or property damage could occur from contact with overhead utilities while operating the Geoprobe.	2. If overhead hazards are present, established overhead utility procedures will be followed. When possible, employees will avoid areas with overhead hazards. Employees will avoid contact with overhead lines when raising the probe unit hammer assembly to its highest position. Employees will not drive the machine with the probe cylinder extended.
	3. Contact with underground utilities.	3. Testing sites.	3. Injury, death or property damage could occur from contact with underground utilities when lowering probe rods into the ground to insert and install monitoring wells.	3. Prior to starting work, employees will call for a utility locate (e.g., call 811 or corresponding phone number). If underground utilities are present, established underground utility procedures will be followed.
MOTION	1. Driving to each site. 2. Slips and trips.	1. Road. 2. Uneven terrain, slick/muddy/wet surfaces and/or steep slopes.	1. Incidents could occur when driving resulting in personal injury and/or property damage. 2. Personal injury such as sprains and muscle/back strains could result from slips	1. Employees will follow defensive driving techniques when operating a vehicle. 2. Workers will wear work boots with good traction and ankle support. Employees will plan their path and walk cautiously.



**PTS-SOP-GEOPROBE-08;
GEOPROBE 0.5-IN. X 1.4-IN. OD AND
0.75-IN. X 1.4-IN. OD PREPACKED
SCREEN MONITORING WELLS**

STATUS: IN PROGRESS
DATE ISSUED: 11/05/13
REVISION: 0
PAGE 18 of 37

HSSE CONSIDERATIONS

This section to be completed with concurrence from the Safety Officer.

	<p>3. Bending, squatting and kneeling.</p> <p>4. Improper body mechanics.</p> <p>5. Struck by and/or caught in between heavy equipment or vehicles.</p>	<p>3. Testing sites, when assembling and retrieving probe rods and well components from the subsurface.</p> <p>4. Testing sites.</p> <p>5. Testing sites.</p>	<p>and trips.</p> <p>3. Bending, squatting and kneeling could result in muscle/back strains or other injuries.</p> <p>4. Back injuries and muscle/back strains could result when using improper techniques to lift and carry probe rods and bags of granular bentonite, silica sand, and other grouting materials.</p> <p>Back injuries and muscle/back strains could also result from using improper techniques when pulling probe rods from the subsurface.</p> <p>5. Personnel could be injured if struck by and/or caught in between heavy equipment or vehicles.</p>	<p>3. Employees should stretch prior to starting work and they will take breaks when necessary.</p> <p>4. Personnel will use proper lifting techniques – get a good grip, keep the load close to the body, lift with legs and not with back, and avoid lifting loads above shoulder height. Two people will lift if necessary.</p> <p>Employees will also use good body mechanics when pulling probe rods from the subsurface: bend knees, lean slightly away from the object, keep back and wrists straight, use legs to move the objects. If necessary, personnel will also use the adjustable rod clamps to facilitate the process of retrieving probe rods from the subsurface.</p> <p>5. When applicable, employees will communicate with the contact person of other contractors on site. Personnel will avoid working near other heavy equipment and/or vehicles, when possible. High visibility</p>
--	---	---	---	---



**PTS-SOP-GEOPROBE-08;
 GEOPROBE 0.5-IN. X 1.4-IN. OD AND
 0.75-IN. X 1.4-IN. OD PREPACKED
 SCREEN MONITORING WELLS**

STATUS: IN PROGRESS
DATE ISSUED: 11/05/13
REVISION: 0
PAGE 19 of 37

HSSE CONSIDERATIONS
 This section to be completed with concurrence from the Safety Officer.

	6. Contact with moving components of the Geoprobe.	6. Testing sites, when operating the machine.	6. Adverse health effects could result from touching moving components when operating the Geoprobe.	<p>clothing will be worn.</p> <p>6. Employees will not touch moving components of the machine. Personnel will tie back long hair and will not wear loose clothing and jewelry. Work gloves are required when operating the machine.</p> <p>All personnel will be clear of all moving parts before starting the engine.</p> <p>Operators will stand to the control side of the machine, clear of the probe foot and derrick, while operating the controls. Personnel will never reach across the probe assembly to manipulate the machine controls.</p>
	7. Pinch points.	7. During equipment assembly.	7. Employees could be exposed to hand injuries such as lacerations, punctures, cuts and pinched fingers when assembling the probe rods and well components.	7. Employees will always wear work gloves when operating the Geoprobe and handling its components.
	8. Flying debris/grout material.	8. During equipment assembly and installation of monitoring wells.	8. Eye injuries could result from flying debris/grout material.	8. Employees will wear safety glasses at all times.



**PTS-SOP-GEOPROBE-08;
 GEOPROBE 0.5-IN. X 1.4-IN. OD AND
 0.75-IN. X 1.4-IN. OD PREPACKED
 SCREEN MONITORING WELLS**

STATUS: IN PROGRESS
DATE ISSUED: 11/05/13
REVISION: 0
PAGE 20 of 37

HSSE CONSIDERATIONS				
This section to be completed with concurrence from the Safety Officer.				
		Also, when using the high-pressure grout pump (Geoprobe® Model GS1000 or GS500).		
GRAVITY	1. Falls from slips and trips. 2. Falling equipment and/or tools.	1. Uneven terrain, slick/muddy/ wet surfaces and steep slopes. 2. Testing sites.	1. Workers could be injured if they fall causing bruises, scrapes, or broken bones. 2. Personnel could be injured if exposed to falling equipment and/or tools (e.g., probe rods) when operating the Geoprobe.	1. Workers will wear work boots with good traction and ankle support. Employees will plan their path and walk cautiously. 2. Employees will wear steel-toed boots and hard hat when operating the Geoprobe. Personnel will practice good housekeeping at all times and keep the work area organized.
THERMAL	1. Cold/heat stress. 2. Hypothermia/frostbite.	1. Sites. 2. Sites where air temperature is 35.6°F (2°C) or less.	1. Exposure to cold climates may result in cold burns, frostbites, and hypothermia. Exposure to high temperatures may result in heat cramps, heat exhaustion, or heat stroke. 2. Workers whose clothing becomes wet may be exposed to hypothermia and/or frostbite.	1. Training on signs and symptoms of cold/heat stress is required. Personnel will wear appropriate clothing when working outdoors. Employees will remain hydrated and will have sufficient caloric intakes during the day. 2. Employees will change clothing if it becomes wet.



**PTS-SOP-GEOPROBE-08;
 GEOPROBE 0.5-IN. X 1.4-IN. OD AND
 0.75-IN. X 1.4-IN. OD PREPACKED
 SCREEN MONITORING WELLS**

STATUS: IN PROGRESS
DATE ISSUED: 11/05/13
REVISION: 0
PAGE 21 of 37

HSSE CONSIDERATIONS				
This section to be completed with concurrence from the Safety Officer.				
RADIATION	1. Ultraviolet (UV) radiation.	1. Outdoors.	1. Employees could be exposed to UV radiation during summer months causing sun burns, skin damage, and eye damage.	1. Employees should wear sunscreen. Employees will wear long-sleeve work shirts and long pants. Employees should also use safety glasses with tinted lenses.
BIOLOGICAL	1. Untrained worker. 2. Plants, insects, and animals.	1. Sites. 2. Sites.	1. Adverse health effects or injury could result from lack of training. 2. Exposure to plants, insects, and/or animals may cause rashes, blisters, redness, swelling and other personal injuries.	1. Employees will be properly trained in this procedure and other applicable procedures. All employees operating the machine will be familiar with the basic controls of the machine including the Emergency Kill switch button. 2. Training on the signs and symptoms of exposure to plants, insects, and animals is required. Avoid contact with plants, insects, and animals. First-aid kits will be available on site. Employees with allergies will notify their supervisor.
ADDITIONAL HSSE CONSIDERATIONS				
This section to be completed with concurrence from the Safety Officer.				
REQUIRED PPE	Level D: hard hat, safety glasses, high-visibility work shirt or vest, long pants, steel-toed boots, and work gloves.			
APPLICABLE MSDS	MSDSs will be maintained based on site characterization and contaminants. Hydraulic Fluids. Carbon Monoxide. Granular Bentonite. Silica Sand.			



**PTS-SOP-GEOPROBE-08;
 GEOPROBE 0.5-IN. X 1.4-IN. OD AND
 0.75-IN. X 1.4-IN. OD PREPACKED
 SCREEN MONITORING WELLS**

STATUS: IN PROGRESS
 DATE ISSUED: 11/05/13
 REVISION: 0
 PAGE 22 of 37

HSSE CONSIDERATIONS	
This section to be completed with concurrence from the Safety Officer.	
	Cement.
REQUIRED PERMITS/FORMS	Daily Toolbox Meeting Record and TSEA, where applicable.
ADDITIONAL TRAINING	OSHA 40-hour HAZWOPER/8-hour Refresher.

DRAWINGS, DOCUMENTS, AND TOOLS/EQUIPMENT																																					
The following documents should be referenced to assist in completing the associated task.																																					
P&IDS																																					
DRAWINGS	Map with site location and sample locations.																																				
ROUTINE TASKS	Bending, squatting, kneeling, lifting, pulling, visual verification of performance, and data recording.																																				
RELATED SOPs/PROCEDURES/WORK PLANS	Related SOPs: PTS-SOP-DE-01 Personnel Decontamination Procedures.																																				
TOOLS	<p>The following equipment is required to install a permanent monitoring well with the Geoprobe® 1.4-inch OD prepacked screens and direct push system. Refer to Figures 3.1 and 3.2 for illustrations of well components.</p> <table border="1" style="margin-left: auto; margin-right: auto;"> <thead> <tr> <th style="text-align: center;">0.5-IN. X 1.4-IN. OD PREPACK WELL COMPONENTS</th> <th style="text-align: center;">Quantity</th> <th style="text-align: center;">Part Number</th> </tr> </thead> <tbody> <tr> <td>0.5-in. x 1.4-in. OD Prepacked Screen, 3-ft. length</td> <td style="text-align: center;">variable</td> <td style="text-align: center;">GW2010</td> </tr> <tr> <td>0.5-in. x 1.4-in. OD Prepacked Screen, 5-ft. length</td> <td style="text-align: center;">variable</td> <td style="text-align: center;">GW2020</td> </tr> <tr> <td>Snap-Lock Connector Assembly, 0.5-in. sch. 80</td> <td style="text-align: center;">-1-</td> <td style="text-align: center;">GW2030</td> </tr> <tr> <td>Expandable Anchor Point, 2.5-in. OD</td> <td style="text-align: center;">-1-</td> <td style="text-align: center;">GW2040</td> </tr> <tr> <td>PVC Riser, 0.5-in. sch. 80, 5-ft. length</td> <td style="text-align: center;">variable</td> <td style="text-align: center;">GW2050</td> </tr> <tr> <td>O-rings for 0.5-in. PVC Riser, Pkg. of 25</td> <td style="text-align: center;">variable</td> <td style="text-align: center;">GW430R</td> </tr> <tr> <td>PVC Top Cap, 0.5-in. sch. 80 Flush Thread</td> <td style="text-align: center;">-1-</td> <td style="text-align: center;">GW2055</td> </tr> <tr> <td>Locking Well Plug, for 0.5-in. sch. 80 riser</td> <td style="text-align: center;">-1-</td> <td style="text-align: center;">WP1750</td> </tr> <tr> <td>Vinyl Cap, 0.812-in. ID (optional)</td> <td style="text-align: center;">-1-</td> <td style="text-align: center;">AT441</td> </tr> <tr> <td>PVC Bottom Plug, 0.5-in. sch. 80 Flush Thread (optional)</td> <td style="text-align: center;">-1-</td> <td style="text-align: center;">GW2056</td> </tr> <tr> <td>Expandable Drive Point, 2.125-in. rods / 2.5-in.</td> <td style="text-align: center;">-1-</td> <td style="text-align: center;">AT2015</td> </tr> </tbody> </table>	0.5-IN. X 1.4-IN. OD PREPACK WELL COMPONENTS	Quantity	Part Number	0.5-in. x 1.4-in. OD Prepacked Screen, 3-ft. length	variable	GW2010	0.5-in. x 1.4-in. OD Prepacked Screen, 5-ft. length	variable	GW2020	Snap-Lock Connector Assembly, 0.5-in. sch. 80	-1-	GW2030	Expandable Anchor Point, 2.5-in. OD	-1-	GW2040	PVC Riser, 0.5-in. sch. 80, 5-ft. length	variable	GW2050	O-rings for 0.5-in. PVC Riser, Pkg. of 25	variable	GW430R	PVC Top Cap, 0.5-in. sch. 80 Flush Thread	-1-	GW2055	Locking Well Plug, for 0.5-in. sch. 80 riser	-1-	WP1750	Vinyl Cap, 0.812-in. ID (optional)	-1-	AT441	PVC Bottom Plug, 0.5-in. sch. 80 Flush Thread (optional)	-1-	GW2056	Expandable Drive Point, 2.125-in. rods / 2.5-in.	-1-	AT2015
0.5-IN. X 1.4-IN. OD PREPACK WELL COMPONENTS	Quantity	Part Number																																			
0.5-in. x 1.4-in. OD Prepacked Screen, 3-ft. length	variable	GW2010																																			
0.5-in. x 1.4-in. OD Prepacked Screen, 5-ft. length	variable	GW2020																																			
Snap-Lock Connector Assembly, 0.5-in. sch. 80	-1-	GW2030																																			
Expandable Anchor Point, 2.5-in. OD	-1-	GW2040																																			
PVC Riser, 0.5-in. sch. 80, 5-ft. length	variable	GW2050																																			
O-rings for 0.5-in. PVC Riser, Pkg. of 25	variable	GW430R																																			
PVC Top Cap, 0.5-in. sch. 80 Flush Thread	-1-	GW2055																																			
Locking Well Plug, for 0.5-in. sch. 80 riser	-1-	WP1750																																			
Vinyl Cap, 0.812-in. ID (optional)	-1-	AT441																																			
PVC Bottom Plug, 0.5-in. sch. 80 Flush Thread (optional)	-1-	GW2056																																			
Expandable Drive Point, 2.125-in. rods / 2.5-in.	-1-	AT2015																																			



**PTS-SOP-GEOPROBE-08;
 GEOPROBE 0.5-IN. X 1.4-IN. OD AND
 0.75-IN. X 1.4-IN. OD PREPACKED
 SCREEN MONITORING WELLS**

STATUS: IN PROGRESS
 DATE ISSUED: 11/05/13
 REVISION: 0
 PAGE 23 of 37

	OD (optional)		
	0.75-IN. X 1.4-IN. OD PREPACK WELL COMPONENTS	Quantity	Part Number
	0.75-in. x 1.4-in. OD Prepacked Screen, 3-ft. length	variable	11678
	0.75-in. x 1.4-in. OD Prepacked Screen, 5-ft. length	variable	17466
	Snap-Lock Connector Assembly, 0.75-inch sch. 40	-1-	17469
	Expendable Anchor Point, 2.5-in. OD	-1-	GW2040
	PVC Riser, 0.75-in. sch. 40, 5-ft. length	variable	11747
	O-rings for 0.75-in. PVC Riser, pkg. of 25	variable	GW4401R
	Vinyl Cap, 1.0-in. ID	-1-	12258
	Locking Well Plug, for 0.75-in. sch. 40 riser	-1-	WP1775
	PVC Bottom Plug, 0.75-in. sch. 40 Flush Thread (optional)	-1-	12385
	Expendable Drive Point, 2.125-in. rods / 2.5-in. OD (optional)	-1-	AT2015
	MONITORING WELL ACCESSORIES	Quantity	Part Number
	Well Cover, flush-mount, 4-in. x 12-in., cast iron / ABS skirt (optional)	-1-	WP1741
	Well Cover, flush-mount, 7-in. x 10-in., cast iron / galvanized skirt (optional)	-1-	WP1771
	Sand, environmental grade (20/40 mesh)	variable	AT95
	Bentonite, granular (8 mesh)	variable	AT91
	Bentonite, powdered (200 mesh)	variable	AT92
	Portland Cement, Type I	variable	
	Concrete Mix (premixed cement and aggregate)	variable	
	Clean Water (of suitable quality for exposure to well components)	variable	



**PTS-SOP-GEOPROBE-08;
GEOPROBE 0.5-IN. X 1.4-IN. OD AND
0.75-IN. X 1.4-IN. OD PREPACKED
SCREEN MONITORING WELLS**

STATUS: IN PROGRESS
DATE ISSUED: 11/05/13
REVISION: 0
PAGE 24 of 37

GEOPROBE® TOOLS AND EQUIPMENT	Quantity	Part Number
O-rings for 2.125-in. Probe Rod, pkg. of 25	variable	AT2100R
Drive Cap, 2.125-in.	-1-	AT2101
Expendable Point Holder, 2.125 x 36, 48 or 60 in.	-1-	AT2110, AT2111, or AT2112
Probe Rod, 2.125-in. x 36, 48, or 60 in.	variable	AT2136, AT2148, or AT2160
Probe Rod, 2.125-in. x 1 meter (optional)	variable	AT2139
Rod Grip Puller Assembly (GH40) or Rod Grip Handle (GH60)	-1-	GH2150K or 9640
Extension Rod, 36-, 48-, or 60-in.	variable	AT67, AT671, or 10073
Extension Rod, 1 meter (optional)	variable	AT675
Extension Rod Coupler	variable	AT68
Extension Rod Handle	-1-	AT69
Extension Cord Quick Links (optional)	variable	AT694K
Grout Machine	-1-	GS1000 or GS500
Grout System Accessories	-1-	GS1010 or GS1012
Water Level Sounder	-1-	GW1200
Screen Push Adapter	-1-	GW1535
Stainless Steel Mini-Bailer Assembly (optional)	-1-	GW41
Pneumatic Bladder Pump (optional)	-1-	GW1400 Series
Tubing Bottom Check Valve	-1-	GW42
Polyethylene Tubing, 3/8-in. OD (for sampling, etc.)	variable	TB25L
Nylon Tubing, 3/8-in. OD (for grouting)	variable	11633

Additional Tools and Equipment	Quantity
Locking Pliers	-2-
Pipe Wrench	-2-
Volumetric Measuring Cup	-1-
PVC Cutting Pliers	-1-
Weighted Measuring Tape (optional)	-1-
Small Funnel or Flexible Container (for pouring sand)	-1-



**PTS-SOP-GEOPROBE-08;
 GEOPROBE 0.5-IN. X 1.4-IN. OD AND
 0.75-IN. X 1.4-IN. OD PREPACKED
 SCREEN MONITORING WELLS**

STATUS: IN PROGRESS
DATE ISSUED: 11/05/13
REVISION: 0
PAGE 25 of 37

	Duct or Electrical Tape Roll	-1-
	Bucket or Tub (for dry grout material, water, and mixing)	-3-
FORMS/CHECKLIST		

APPROVALS/CONCURRENCE	
<p>By signing this document, all parties acknowledge the completeness and applicability of this SOP for its intended purpose. Also, by signing this document, it serves as acknowledgement that I have received training on the procedure and associated competency testing.</p>	
PROJECT MANAGER	DATE
SAFETY OFFICER	DATE
CREW LEAD or SAMPLER LEAD	DATE
SAMPLER	DATE



**PTS-SOP-GEOPROBE-08;
 GEOPROBE 0.5-IN. X 1.4-IN. OD AND
 0.75-IN. X 1.4-IN. OD PREPACKED
 SCREEN MONITORING WELLS**

STATUS: IN PROGRESS
DATE ISSUED: 11/05/13
REVISION: 0
PAGE 26 of 37

APPROVALS/CONCURRENCE

By signing this document, all parties acknowledge the completeness and applicability of this SOP for its intended purpose. Also, by signing this document, it serves as acknowledgement that I have received training on the procedure and associated competency testing.

OTHER	DATE
OTHER	DATE

Revisions:

Rev.	Description	Date	Approval



**PTS-SOP-GEOPROBE-08;
GEOPROBE 0.5-IN. X 1.4-IN. OD AND
0.75-IN. X 1.4-IN. OD PREPACKED
SCREEN MONITORING WELLS**

STATUS: IN PROGRESS
DATE ISSUED: 11/05/13
REVISION: 0
PAGE 27 of 37

Geoprobe Prepacked Screen Monitoring Well - Figures

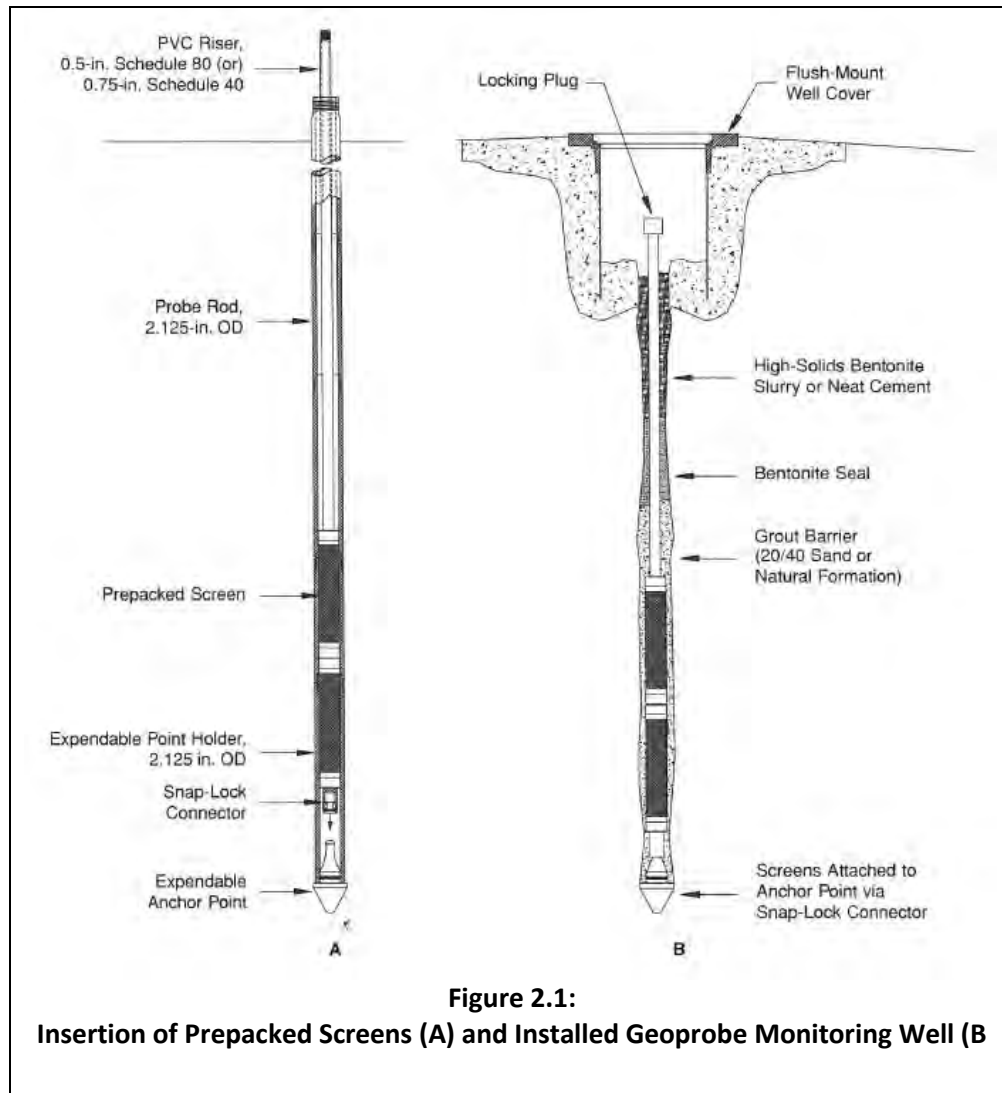



**PTS-SOP-GEOPROBE-08;
GEOPROBE 0.5-IN. X 1.4-IN. OD AND
0.75-IN. X 1.4-IN. OD PREPACKED
SCREEN MONITORING WELLS**

STATUS: IN PROGRESS
DATE ISSUED: 11/05/13
REVISION: 0
PAGE 28 of 37

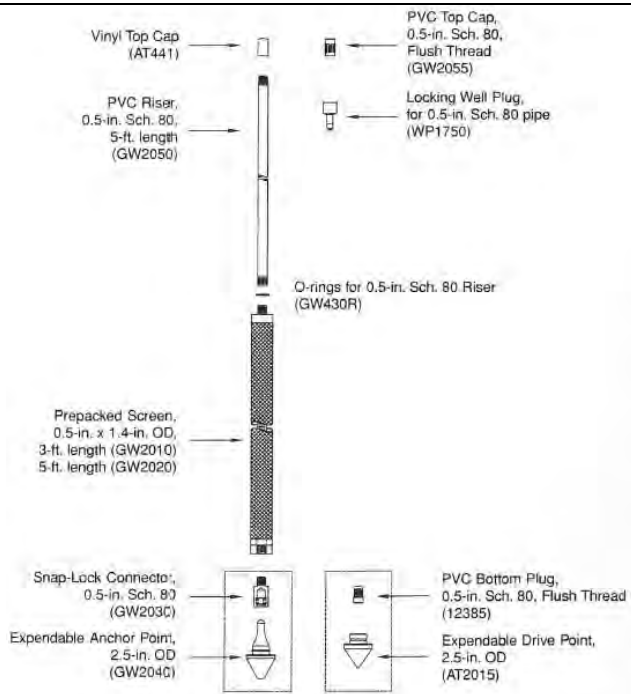

Figure 3.1:

0.7-in. x 1.4-in. OD Prepacked Screen Monitoring Well Parts

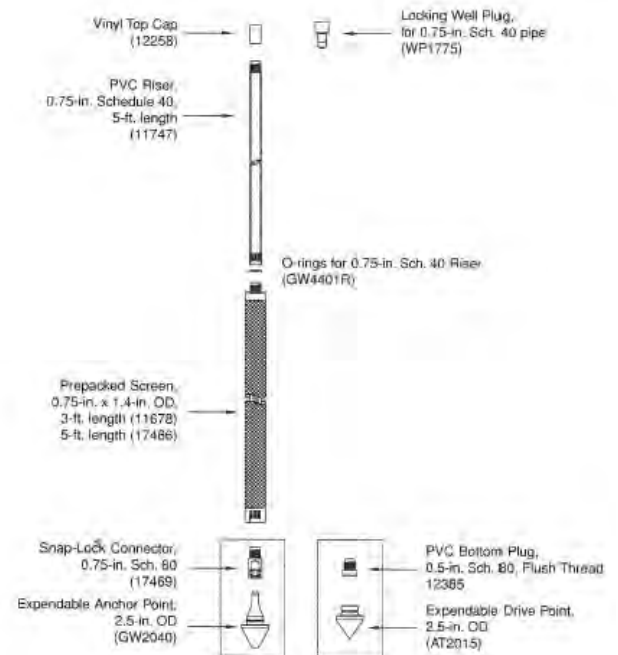

Figure 3.2:

0.75-in. x 1.4-in. OD Prepacked Screen Monitoring Well Parts

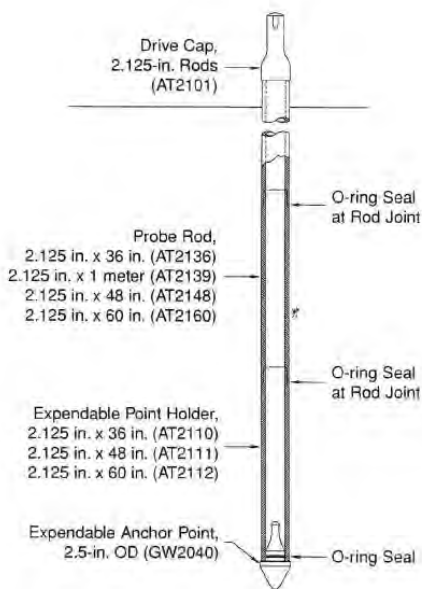

Figure 4.1:

Expendable Anchor Point Driven to Depth

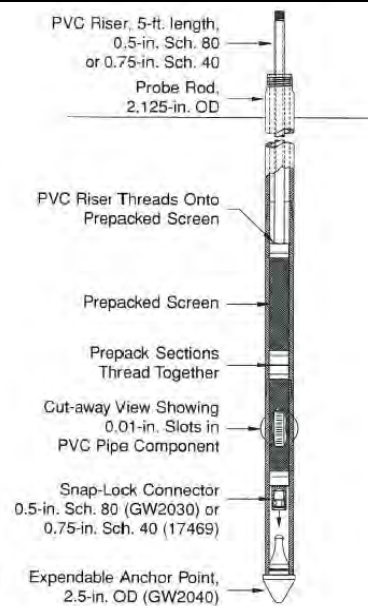

Figure 4.2:

Prepacked Screens Inside Probe Rod String



**PTS-SOP-GEOPROBE-08;
GEOPROBE 0.5-IN. X 1.4-IN. OD AND
0.75-IN. X 1.4-IN. OD PREPACKED
SCREEN MONITORING WELLS**

STATUS: IN PROGRESS
DATE ISSUED: 11/05/13
REVISION: 0
PAGE 29 of 37

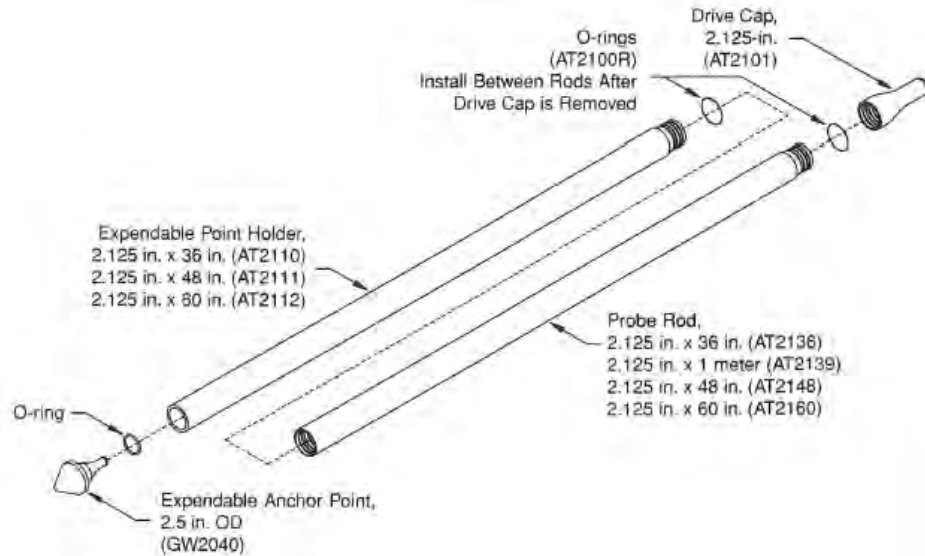

**Figure 4.3:
2.125-inch OD Probe Rod Assembly**

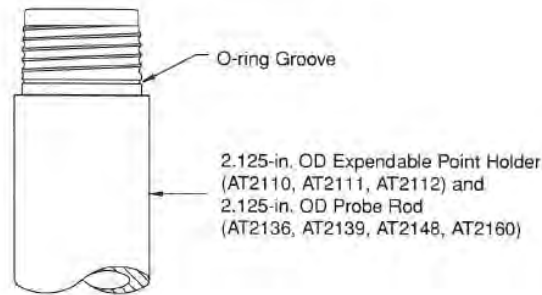

**Figure 4.4:
O-ring Groove in 2.125-inch Expendable Point Holders and Probe Rods**



**PTS-SOP-GEOPROBE-08;
 GEOPROBE 0.5-IN. X 1.4-IN. OD AND
 0.75-IN. X 1.4-IN. OD PREPACKED
 SCREEN MONITORING WELLS**

STATUS: IN PROGRESS
 DATE ISSUED: 11/05/13
 REVISION: 0
 PAGE 30 of 37

0.5-inch Schedule 80 Prepack Components

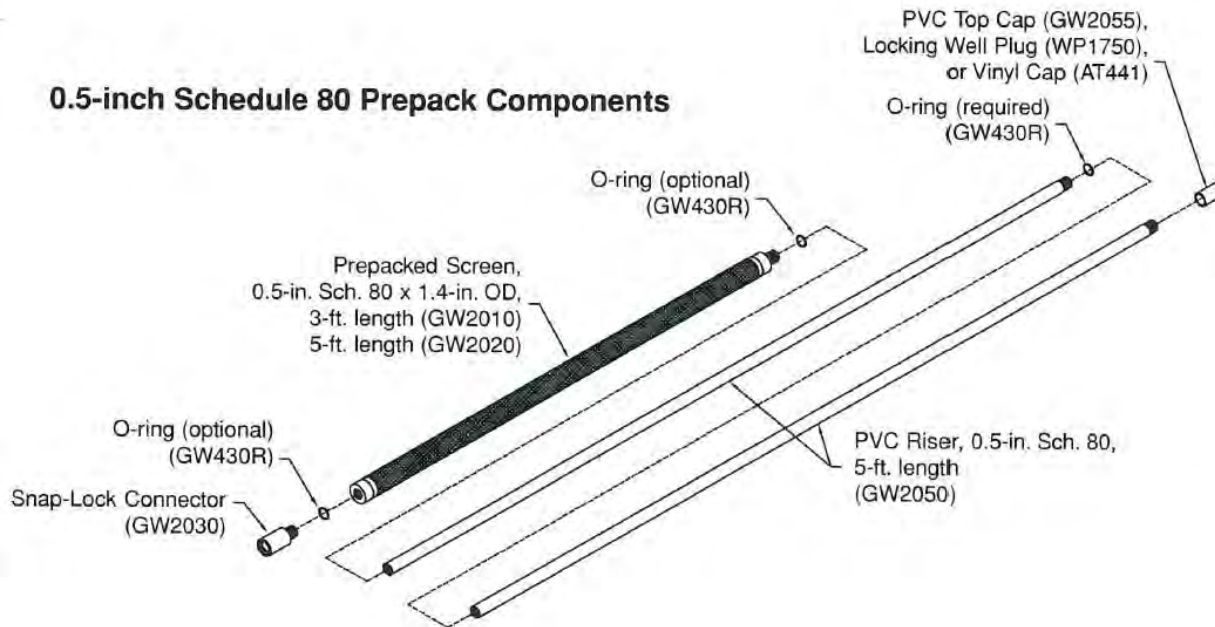

0.75-inch Schedule 40 Prepack Components

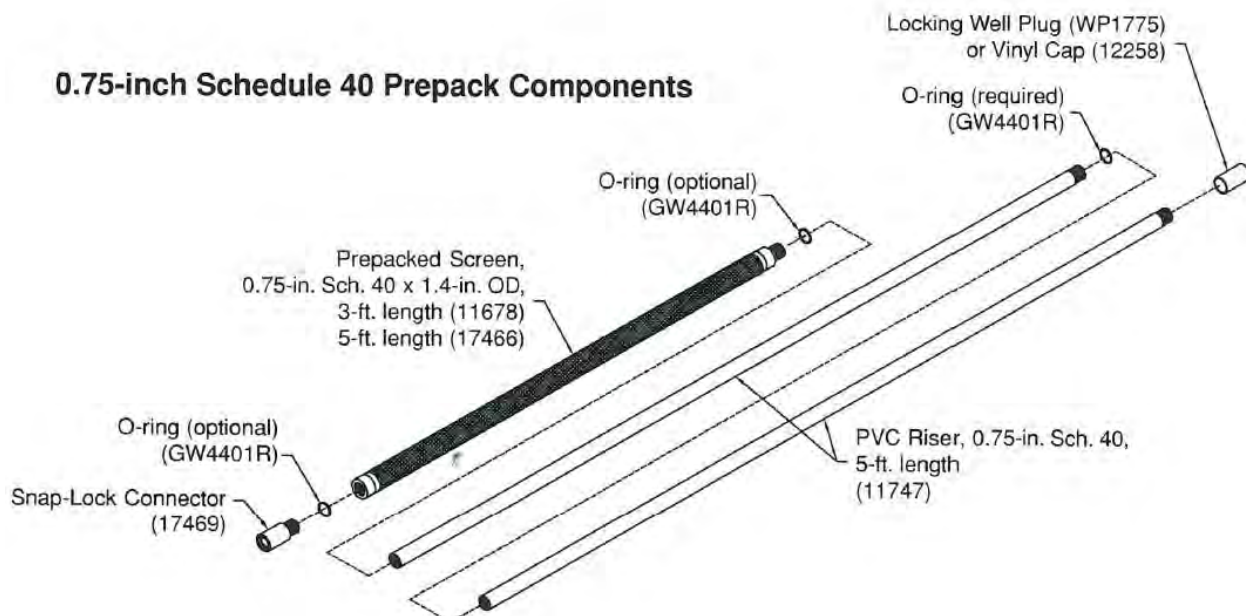

Figure 4.5:

0.5-inch Schedule 80 and 0.75-inch Schedule 40 Prepacked Screen Components



**PTS-SOP-GEOPROBE-08;
GEOPROBE 0.5-IN. X 1.4-IN. OD AND
0.75-IN. X 1.4-IN. OD PREPACKED
SCREEN MONITORING WELLS**

STATUS: IN PROGRESS
DATE ISSUED: 11/05/13
REVISION: 0
PAGE 31 of 37

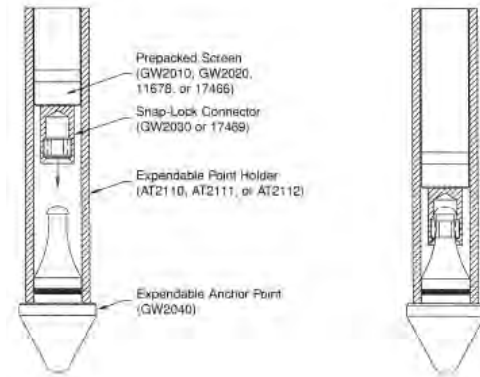

**Figure 4.6:
Connecting Prepack(s) to Expendable Anchor Point**

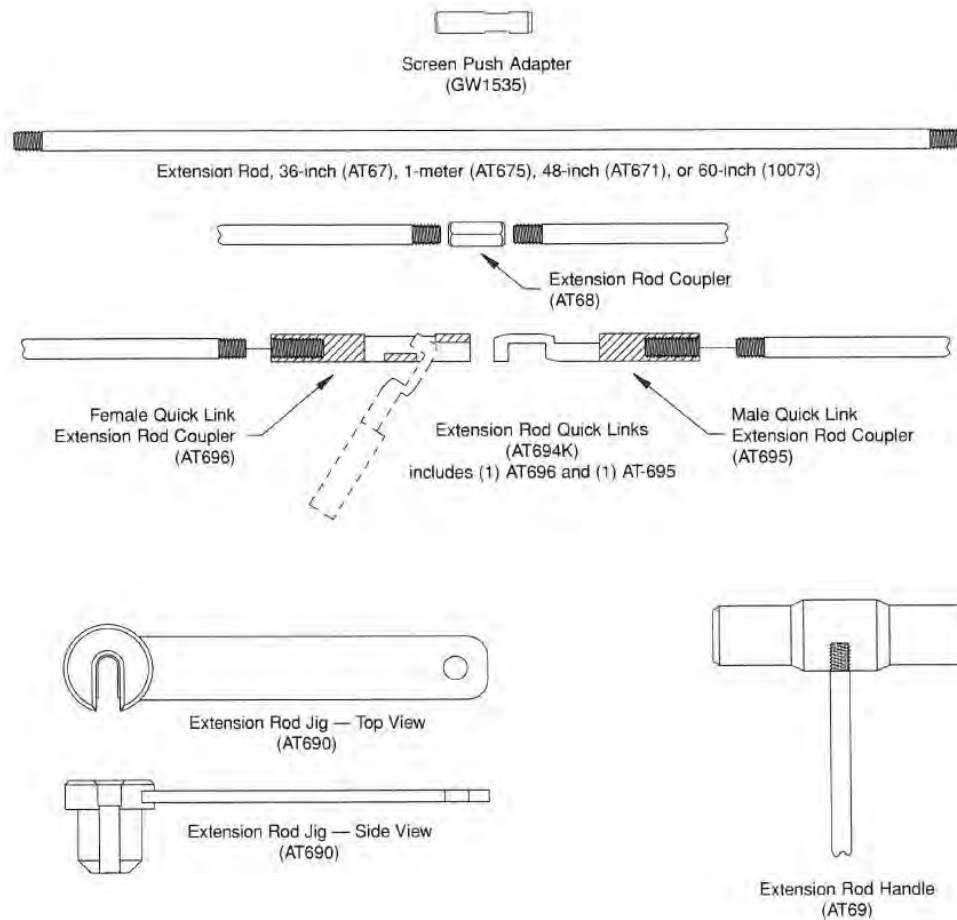
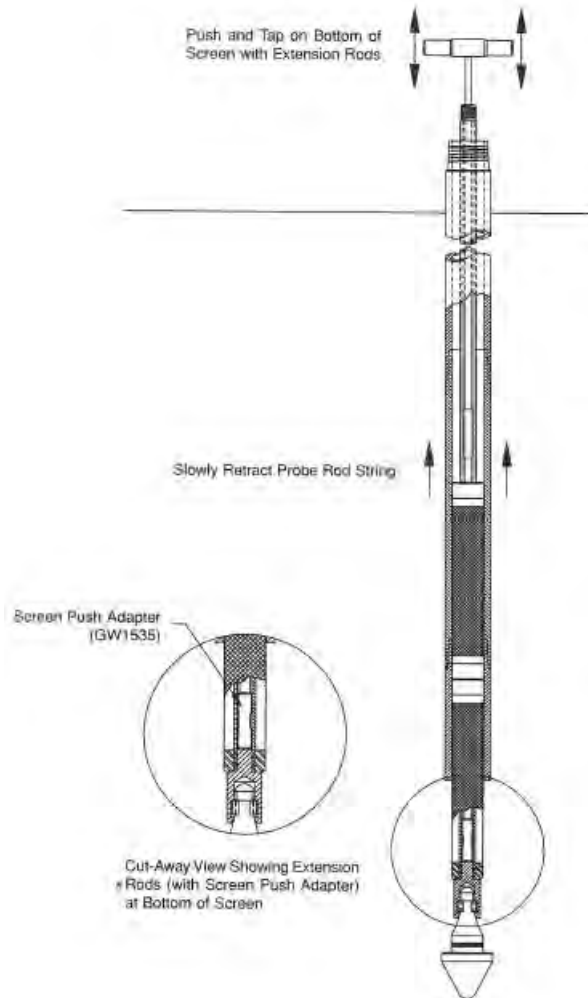

**Figure 4.7:
Geoprobe Extension Rods and Accessories**



**PTS-SOP-GEOPROBE-08;
GEOPROBE 0.5-IN. X 1.4-IN. OD AND
0.75-IN. X 1.4-IN. OD PREPACKED
SCREEN MONITORING WELLS**

STATUS: IN PROGRESS
DATE ISSUED: 11/05/13
REVISION: 0
PAGE 32 of 37

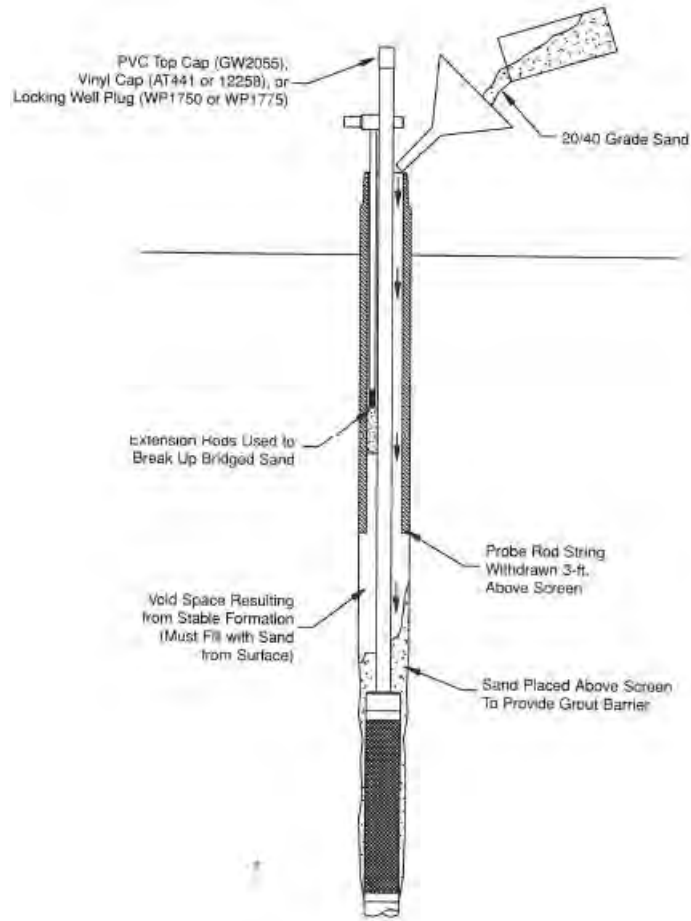

**Figure 4.8:
Use Extension Rods to Tap Out Wedged Screens**



**PTS-SOP-GEOPROBE-08;
GEOPROBE 0.5-IN. X 1.4-IN. OD AND
0.75-IN. X 1.4-IN. OD PREPACKED
SCREEN MONITORING WELLS**

STATUS: IN PROGRESS
DATE ISSUED: 11/05/13
REVISION: 0
PAGE 33 of 37

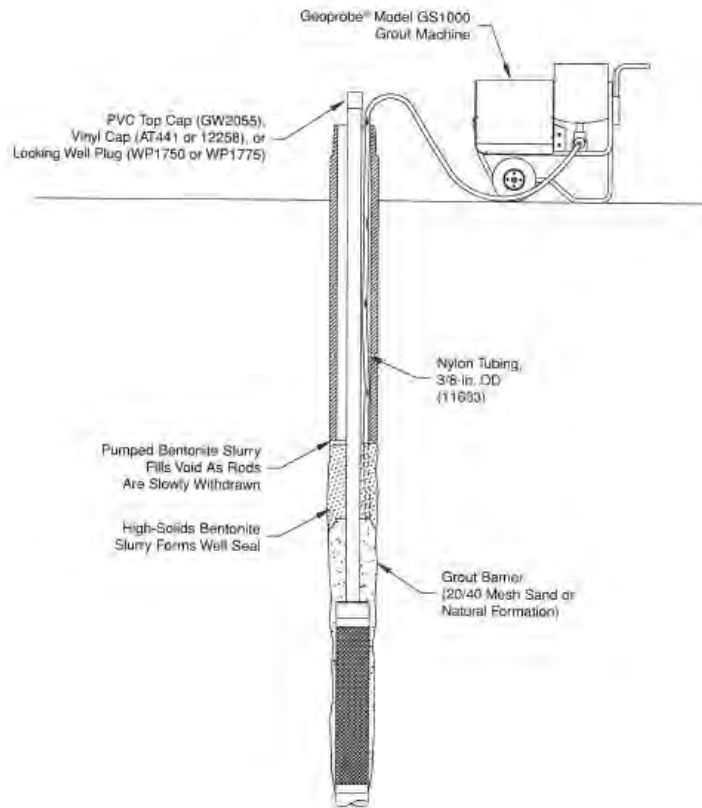

**Figure 4.9:
Installing Grout Barrier from Ground Surface with 20/40 Mesh Sand**



**PTS-SOP-GEOPROBE-08;
GEOPROBE 0.5-IN. X 1.4-IN. OD AND
0.75-IN. X 1.4-IN. OD PREPACKED
SCREEN MONITORING WELLS**

STATUS: IN PROGRESS
DATE ISSUED: 11/05/13
REVISION: 0
PAGE 34 of 37

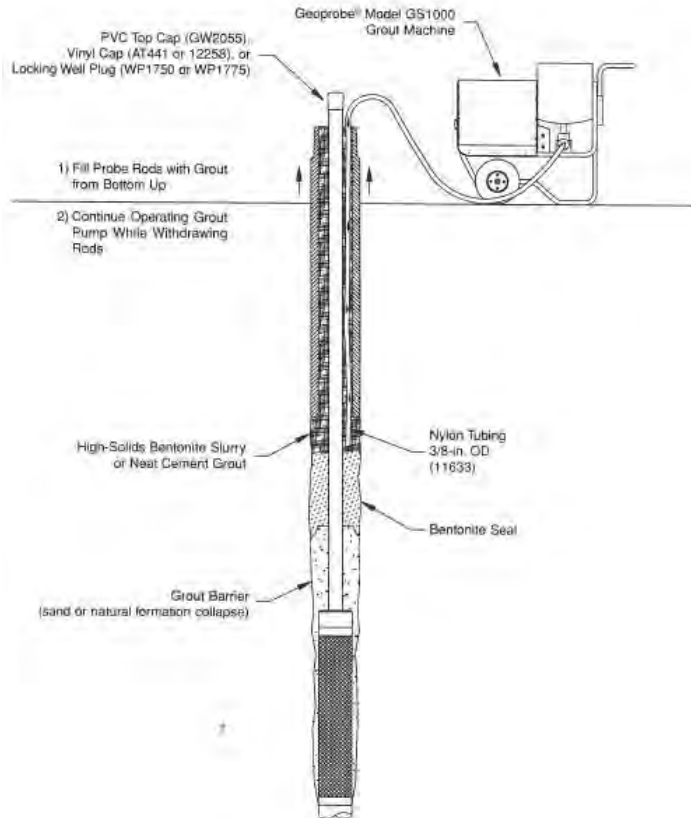

**Figure 4.10:
Providing Bentonite Seal With Geoprobe® Model GS1000 Grout Machine**



**PTS-SOP-GEOPROBE-08;
GEOPROBE 0.5-IN. X 1.4-IN. OD AND
0.75-IN. X 1.4-IN. OD PREPACKED
SCREEN MONITORING WELLS**

**STATUS: IN PROGRESS
DATE ISSUED: 11/05/13
REVISION: 0
PAGE 35 of 37**

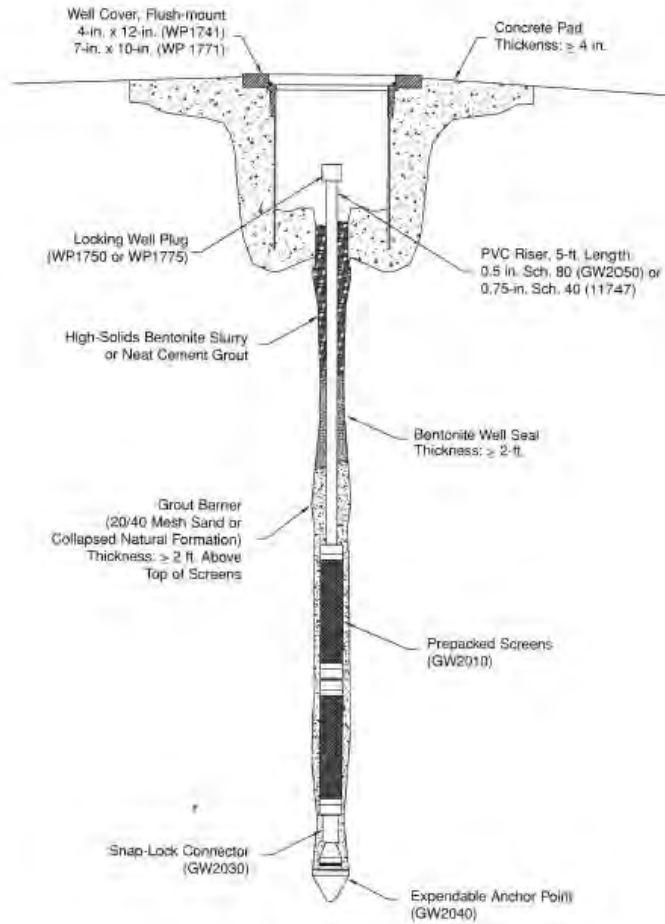

**Figure 4.11:
Grouting Well Annulus with Geoprobe® Model GS1000 Grout Machine**



**PTS-SOP-GEOPROBE-08;
GEOPROBE 0.5-IN. X 1.4-IN. OD AND
0.75-IN. X 1.4-IN. OD PREPACKED
SCREEN MONITORING WELLS**

STATUS: IN PROGRESS
DATE ISSUED: 11/05/13
REVISION: 0
PAGE 36 of 37

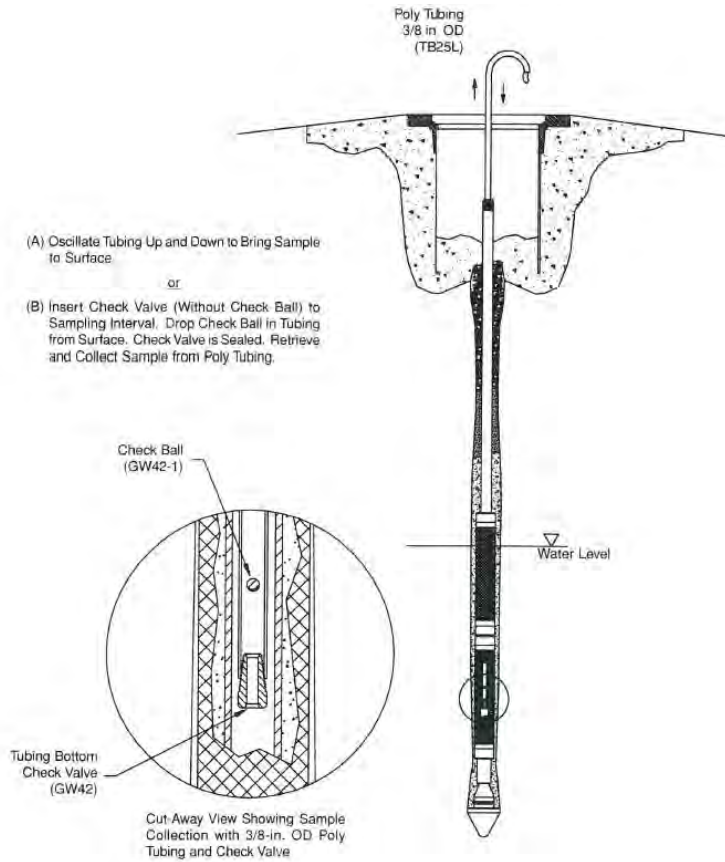

**Figure 4.12:
A Properly Installed Geoprobe® Prepacked Screen Monitoring Well**



**PTS-SOP-GEOPROBE-08;
GEOPROBE 0.5-IN. X 1.4-IN. OD AND
0.75-IN. X 1.4-IN. OD PREPACKED
SCREEN MONITORING WELLS**

STATUS: IN PROGRESS
DATE ISSUED: 11/05/13
REVISION: 0
PAGE 37 of 37



**Figure 4.13:
Sampling with Polyethylene Tubing and a Tubing Bottom Check Valve**



**SOP-GEOPROBE-09;
DH133 AUTOMATIC DROP
HAMMER**

STATUS: DRAFT
DATE ISSUED:
11/16/2020
REVISION: 1
PAGE 1 of 12

PURPOSE	To provide standard instructions for using a DH133 Automatic Drop Hammer to perform Standard Penetration Test (SPT).
SCOPE	This practice has been prepared for the Pioneer Technical Services, Inc. (Pioneer) workforce and applies to work carried out by and on behalf of Pioneer. All members of the Pioneer workforce who conduct the work shall be trained and competent in the risk-assessed work described below.

WORK INSTRUCTIONS

The following instructions are intended to provide sufficient guidance to perform the task in a safe, accurate, and reliable manner. Should these instructions present information that is inaccurate or unsafe, operations personnel must bring the issue to the attention of the Project Manager and the appropriate revisions made. All work carried under this SOP will be consistent with procedures and policies described in the appropriate Operation, Maintenance, and Monitoring (O&M) Plan (where applicable), appropriate Site-Specific Health and Safety Plan (SSHASP), and Pioneer Corporate Health and Safety Plan (HASP).

TASK	INSTRUCTIONS
Assembling and Driving the Outer and Inner Rods	<p>An outer casing is first driven through the undisturbed soil with the probe unit hammer assembly to reach the top of the testing intervals. Specific instructions are listed below.</p> <ol style="list-style-type: none"> 1. Align the probe unit hammer assembly by pulling the hammer pin and swinging the hammer over to the identified/applicable location. 2. Thread the SPT cutting shoe to the leading end of a heavy-weight outer probe rod (3.25-in. ODx60-in. length). 3. Thread the SPT solid drive tip to the leading end of a heavy-weight inner rod (1.25-in ODx60-in length). 4. Insert the heavy-weight inner rod into the outer rod until the solid drive tip partially extends from the bottom of the cutting shoe. 5. Slip a threadless drive cap to the top of the heavy-weight inner rod. 6. Place a threadless drive cap on top of the heavy-weight outer rod. 7. Raise the probe unit hammer assembly to its highest position by fully extending the probe cylinder until it stops. 8. Position the assembled rods directly under the probe unit hammer assembly with the cutting shoe centered between the probe foot. The heavy-weight outer rod should now be parallel to the probe derrick. A magnetic level should be placed on the heavy-weight rod to check rod verticality. 9. Start the probe unit hammer assembly using both down feed and hammer levers to advance the assembled rods into the ground until reaching the desired testing depth below ground surface.



**SOP-GEOPROBE-09;
DH133 AUTOMATIC DROP
HAMMER**

STATUS: DRAFT
DATE ISSUED:
11/16/2020
REVISION: 1
PAGE 2 of 12

<p>Using the DH133 Automatic Drop Hammer</p>	<p>Once the rod assembly has been driven into the ground to reach the top of the desired testing interval, the operator can start using the DH133 Automatic Drop Hammer (drop hammer). Step by step instructions are listed below.</p> <ol style="list-style-type: none">1. Remove the threadless drive cap on top of the heavy-weight outer rod.2. Remove the threadless inner rod drive cap.3. Remove the heavy-weight inner rod and remove the solid drive tip.4. Assemble split spoon sampler and thread it to the bottom of the heavy-weight inner rod.5. Insert the heavy-weight inner rod and the split spoon string into the outer rod that was previous driven into the ground. Add inner rod as necessary until the split spoon sampler is resting on bottom.6. Using a marker, mark the desired testing intervals (typically 6', 12", 18" and 24") on the heavy-weight inner rod.7. Unlatch and swing the Geoprobe® hammer directly above the heavy-weight inner rod.8. Activate the drop hammer on by using the axillary hydraulic switch to advance the heavy-weight inner rod and split spoon into the ground until reaching the desired testing depth. The operator will count and record the number of blow counts that is takes to reach each testing interval previously marked on the heavy-weight inner rod. If the blow count reaches 50 and the full 6-inch interval has not been sampled, it will be called refusal and the hammer will be stopped.9. Reposition the Geoprobe® hammer by the swing function. Adjust Geoprobe® so the probe unit hammer assembly is directly above the heavy-weight inner rod. Using the probe machine and a threaded pull cap, pull up the heavy-weight inner rod and split spoon. The outer rod remains in the ground.10. Remove the split spoon from the heavy-weight inner rod. Disassemble the split spoon sampler by removing the cutting shoe and adapter pin from either end of the split spoon. Open the split spoon and collect the soil sample. Then, decontaminate the split spoon components as necessary, assemble the two halves of the sample tube, and thread the cutting shoe



**SOP-GEOPROBE-09;
DH133 AUTOMATIC DROP
HAMMER**

**STATUS: DRAFT
DATE ISSUED:
11/16/2020
REVISION: 1
PAGE 3 of 12**

back onto the leading end of the split spoon and the adapter pin onto the opposite end.

11. Thread a solid drive tip onto the leading end of a heavy-weight inner rod and connect an additional heavy-weight inner rod to other end of the rod.
12. Place the threadless drive cap onto the top of the heavy-weight inner rod tool string.
13. Insert the assembled heavy-weight inner rod tool string into the 3.25" outer rod that was previously driven into the ground.
14. Using the overhead winch, raise a heavy-weight outer rod and feed it over the protruding heavy-weight inner rods. Thread the heavy-weight outer rod onto the outer rod that was previously driven into the ground.
15. Place a threadless drive cap on top of the heavy-weight outer rod tool string.
16. Using the probe unit hammer assembly, drive the assembled rods into the ground to the top of the next SPT sample interval.
17. Remove the threadless drive cap from the heavy-weight outer rods and the threaded drive cap from the heavy-weight inner rods.
18. Thread a loop pull cap onto the tool string of heavy-weight inner rods.
19. Connect the overhead winch to the loop pull cap and remove the heavy-weight inner rod tool string.
20. Remove the solid drive tip from the heavy-weight inner rods and thread a split spoon sampler onto the assembled heavy-weight inner rods.
21. Replace the loop pull cap on the heavy-weight inner rods with a threaded drive cap.
22. Insert the assembled heavy-weight inner rod tool string into the 3.25" outer rod that was previously driven into the ground until it rests on bottom. Once on bottom, mark the inner rod string for the proper SPT intervals
23. Reposition the Geoprobe® so the drop hammer is directly above the heavy-weight inner rods.
24. Activate the drop hammer on to drive the tool string of heavy-weight inner rods and split spoon into the ground until reaching the desired testing depth. The operator will count the number of blow counts that is takes to reach each testing interval marked on the heavy-weight inner rod.

Repeat steps 9 to 24 until reaching the end of the testing depth.



**SOP-GEOPROBE-09;
DH133 AUTOMATIC DROP
HAMMER**

**STATUS: DRAFT
DATE ISSUED:
11/16/2020
REVISION: 1
PAGE 4 of 12**

	<p>Note: as the assembled rods get longer and heavier, use the probe machine, the overhead winch, and/or the adjustable rod clamp to facilitate the process of placing and retrieving rods.</p>
Outer Casing Retrieval	<p>The outer casing may be retrieved in two ways:</p> <ol style="list-style-type: none">1. Entire casing string removed from the ground and remaining probe hole sealed from ground surface with granular bentonite. <p>The outer casing may be pulled from the ground with the probe machine and a pull cap, if the probe hole is to be sealed with granular bentonite from the ground surface. This method is used for shallow probe holes in stable formations only. Such conditions allow the entire probe hole to be sealed with granular bentonite.</p> <ol style="list-style-type: none">2. Casing pulled with probe hole sealed from bottom-up during retrieval. <p>Bottom-up grouting should be performed during casing retrieval in unstable formations where side slough is probable. Such conditions create void spaces in the probe hole if granular bentonite is installed from the ground surface.</p>



HSSE CONSIDERATIONS

This section to be completed with concurrence from the Safety and Health Manager.

<i>SOURCE</i>	<i>HAZARDS</i>	<i>WHERE</i>	<i>HOW, WHEN, RESULT</i>	<i>CONTROLS</i>
CHEMICAL	Contact with impacted soils and water.	Impacted sites, during sample collection and handling.	Adverse health effects could result from ingesting, inhaling, and/or skin/eye contact with impacted soils and water.	Personnel will practice proper personal hygiene – wash hands prior to eating/drinking and when leaving the site. Employees will wear nitrile gloves when collecting and handling samples. Employees will wear work gloves when handling probe rods. Work will be suspended during high wind conditions that produce large amounts of visible impacted dust.
	Hydraulic fluid and diesel.	Geoprobe®.	Employees could be exposed to hydraulic fluid and/or diesel via inhalation, ingestion, and skin/eye contact, when operating the Geoprobe®, or if equipment malfunctions resulting in adverse health effects.	Employees will wear work gloves and eye protection, if contact with hydraulic fluid/diesel is possible. In the event of a spill/leak, personnel will contain the fluid using the spill cleanup material available in the Geoprobe® trailer. Cleanup materials will be disposed of according to the appropriate regulations. All components of the rig will be inspected prior to and at the completion of the task. Non-essential personnel will maintain a 20-foot buffer zone around the equipment.
	Lubricating grease.	Probing location.	Employees could be exposed to lubricating grease via ingestion and skin/eye contact when assembling probe rods resulting in adverse health effects.	Employees will wear work gloves and eye protection when assembling probe rods.



**SOP-GEOPROBE-09;
DH133 AUTOMATIC DROP
HAMMER**

**STATUS: DRAFT
DATE ISSUED:
11/16/2020
REVISION: 1
PAGE 6 of 12**

NOISE	Elevated noise levels.	Geoprobe®.	Employees could be exposed to elevated noise levels when operating the Geoprobe® resulting in irritability, decreased concentration, and noise-induced hearing loss.	Personnel within a 20-foot buffer zone of the Geoprobe® will wear single hearing protection (e.g. earmuffs or earplugs). Non-essential personnel will maintain a 20-foot buffer zone around the Geoprobe®.
ELECTRICAL	Defective electrical lines.	Geoprobe®.	Contact with defective electrical lines could result in personal injury.	Inspect electrical lines of the Geoprobe® prior to and at the completion of the task.
	Contact with overhead utilities.	Probing location.	Injury, death, or property damage could occur from contact with overhead utilities when the hammer assembly is raised to its highest position.	If overhead hazards are present, established overhead utility procedures will be followed. Probe locations will be moved to avoid working around overhead utilities. Employees will maintain the required minimal radial clearance distances based on voltage when working around overhead lines.
	Contact with underground utilities.	Probing location.	Injury, death or property damage could occur from contact with underground utilities when geoprobing.	Prior to starting work, employees will call for a utility locate (i.e., call 811). If underground utilities are present, established underground utility procedures will be followed. Probe locations will be moved to avoid working around underground utilities.
BODY MECHANICS	Lifting and moving rods.	Probing location.	Employees could be exposed to back or muscle strains or sprains when lifting or connecting the Geoprobe® rods.	Employees will follow good lifting techniques including lifting with the legs and not the back, get a good grip, and keep the load close to your body. Two employees will lift the rods if necessary.



**SOP-GEOPROBE-09;
DH133 AUTOMATIC DROP
HAMMER**

**STATUS: DRAFT
DATE ISSUED:
11/16/2020
REVISION: 1
PAGE 7 of 12**

GRAVITY	Falls from slips and trips.	Uneven terrain, slick/muddy/wet surfaces and steep slopes.	Walking on slick/muddy/wet and uneven terrain could cause slips and trips resulting in falls and injuries.	Workers will wear work boots with good traction and ankle support. Employees will plan their path and walk cautiously. Keep work area free of tools/rods. If conditions are wet/muddy, muck boots may be worn. Site can be cleared of snow, if applicable.
	Falling rods.	Probing location.	Heavy rods could slip off of worker's hands while carrying and assembling tool strings causing personal injury.	Employees will use work gloves when assembling and handling rods. Two workers will carry rods, if necessary. All personnel will wear steel-toe boots.
WEATHER	Cold/heat stress	Outdoors.	Exposure to cold climates may result in cold burns, frostbites, and hypothermia. Exposure to high temperatures may result in heat cramps, heat exhaustion, or heat stroke.	Training on signs and symptoms of cold/heat stress is required. Personnel will wear appropriate clothing when working outdoors (e.g. layers). Employees will remain hydrated and will have sufficient caloric intakes during the day. Personnel will follow procedures outlined in applicable SSHASP and/or Pioneer corporate HASP.
	Lightning.	Sites.	Electrocution, injury, death, or equipment damage could be caused by lightning strike.	Employees will follow the 30/30 rule during lightning storms. When the Geoprobe® is running, the Geoprobe helper will watch/listen for lightning and thunder.
RADIATION	Ultraviolet (UV) radiation.	Outdoors.	Employees could be exposed to UV radiation during summer months causing sun burns, skin damage, and eye damage.	Employees will wear sunscreen, long-sleeve work shirts and long pants. Employees will also use safety glasses with tinted lenses.



**SOP-GEOPROBE-09;
DH133 AUTOMATIC DROP
HAMMER**

**STATUS: DRAFT
DATE ISSUED:
11/16/2020
REVISION: 1
PAGE 8 of 12**

BIOLOGICAL	Inexperienced and improperly trained worker.	Sites.	Inexperienced workers and improper training could cause incidents resulting in adverse health effects and/or property damage.	Employees will be properly trained in this procedure and other applicable procedures. All employees operating the Geoprobe® will be familiar with the basic controls of the machine including the Emergency Kill switch button.
	Plants, insects, and animals.	Sites.	Exposure to plants, insects, and/or animals may cause rashes, blisters, redness, and swelling.	Training on the signs and symptoms of exposure to plants, insects, and animals. Avoid contact with plants, insects, and animals. First-aid kits will be available on site. Employees with allergies should notify their supervisor.
MECHANICAL	Geoprobe® shifting.	Probing location, when using the drop hammer and working on a sloped surface.	Personal injury and equipment damage could occur if the Geoprobe® shifts while using the drop hammer and when working on a sloped surface.	When using the drop hammer, do not raise the machine foot more than approximately 6 inches off the ground or the vehicle may become unstable and shift. When working on a sloped surface, position the rig so that it is facing upslope. In the event that the probe unit loses stability, it will roll away from the operator without causing injury.
	Struck by the Geoprobe®/drop hammer.	Operating the Geoprobe®/drop hammer.	Personnel could be injured if struck by the Geoprobe®/drop hammer.	Non-essential personnel will maintain a 20-foot buffer zone around the rig.
	Improper body mechanics.	Assembling, handling, and retrieving	Improper lifting, bending, squatting, and	Personnel will use proper lifting techniques – get a good grip, keep the load close to the



**SOP-GEOPROBE-09;
DH133 AUTOMATIC DROP
HAMMER**

**STATUS: DRAFT
DATE ISSUED:
11/16/2020
REVISION: 1
PAGE 9 of 12**

		<p>rods/sample tubes.</p>	<p>kneeling could result in muscle/back strains or other injuries.</p>	<p>body, lift with legs and not with back, and avoid lifting loads above shoulder height. Two people will lift, if necessary.</p> <p>Employees will also use good body mechanics when retrieving rods/sample tubes: bend knees, lean slightly away from the object, keep back and wrists straight, use legs to move the objects.</p> <p>Employees should stretch prior to starting work and they will take breaks when necessary.</p>
	<p>Back injuries.</p>	<p>Moving the drop hammer with hand dolly.</p>	<p>Back injuries and muscle/back strains could result when using the hand dolly to move the drop hammer.</p>	<p>Employees will inspect the hand dolly (including all wheels) before using it. Two employees will load the drop hammer on the hand dolly. Workers will use proper body mechanics when loading the drop hammer. Employees will make sure the weight is evenly distributed on all wheels of the hand dolly.</p> <p>Employees will always push a hand dolly to move the load, instead of pulling the hand dolly.</p> <p>Personnel will use a belt to keep the drop hammer from shifting or slipping.</p>
	<p>Contact with rotating and moving parts of the drop hammer.</p>	<p>When the drop hammer is in motion.</p>	<p>Fingers/hands could become pinched or caught in moving/rotating parts of the drop hammer resulting in cuts, scrapes, and/or broken bones.</p>	<p>Employees will not touch moving/rotating parts of the drop hammer. Work gloves are required when operating the drop hammer.</p> <p>Operators will stand to the control side of the machine, clear of the probe foot and drop hammer, while operating the</p>



**SOP-GEOPROBE-09;
DH133 AUTOMATIC DROP
HAMMER**

**STATUS: DRAFT
DATE ISSUED:
11/16/2020
REVISION: 1
PAGE 10 of 12**

	Pinch points.	When mounting the drop hammer, while the drop hammer is in motion, assembling probe rods, and extracting probe rods.	Employees could be exposed to hand injuries such as lacerations, punctures, cuts, and pinched fingers.	controls. Personnel will never reach across the probe assembly to manipulate the machine controls. All employees on site will be familiar with the basic controls of the machine including the Emergency Kill switch button.
	Flying debris.	Probing location.	Eye injuries could result from flying debris when driving tool strings into the ground with the drop hammer.	Employees will always wear work gloves. Employees will never place their hands on top of the tool string while raising or lowering the drop hammer.
PRESSURE	Pressurized hydraulic lines.	Geoprobe®.	Faulty pressurized hydraulic lines could burst resulting in personal injury/exposure and hydraulic fluid release.	Employees will wear safety glasses at all times during Geoprobe® operations.
THERMAL	Cold/heat stress.	Outdoors.	Exposure to cold climates may result in cold burns, frostbites, and hypothermia. Exposure to high temperatures may result in	All components of the rig will be inspected prior to and at the completion of the task. Training on signs and symptoms of cold/heat stress. Personnel will wear appropriate clothing when working outdoors. Employees will remain hydrated and will have sufficient caloric intakes during the day. Personnel will



**SOP-GEOPROBE-09;
DH133 AUTOMATIC DROP
HAMMER**

**STATUS: DRAFT
DATE ISSUED:
11/16/2020
REVISION: 1
PAGE 11 of 12**

			heat cramps, heat exhaustion, or heat stroke.	follow procedures outlined in applicable SSHASP and/or Pioneer corporate HASP.
HUMAN FACTORS	Inexperience and improperly trained worker.	Sites.	Inexperience workers and improper training could cause incidents resulting in personal injuries and/or property damage.	Employees will be properly trained int his procedure and other applicable procedures. When starting/stopping for the first time, an experienced operator should be on site to help coach the process. All employees operating the Geoprobe® will be familiar with the basic controls of the machine including the Emergency kill switch button. Employees will implement stop work procedures, if necessary.
SIMOPS	Not applicable.			

ADDITIONAL HSSE CONSIDERATIONS

This section to be completed with concurrence from the Safety and Health Manager.

REQUIRED PPE	Level D PPE, earplugs, and earmuffs.
APPLICABLE SDS	SDSs will be maintained based on-site characterization and contaminants. Hydraulic fluid, diesel, lubricating grease.
REQUIRED PERMITS/FORMS	Per site/project requirements.
ADDITIONAL TRAINING	Per site/project requirements.

DRAWINGS, DOCUMENTS, AND TOOLS/EQUIPMENT

The following documents should be referenced to assist in completing the associated task.

P&IDS	
DRAWINGS	
RELATED SOPs/PROCEDURES/WORK PLANS	
TOOLS	DH133 automatic drop hammer: hitch mounted basket, counterweights, hand dolly, pipe wrench, safety pin, machine vise, work table, and deionized water.
FORMS/CHECKLIST	



**SOP-GEOPROBE-09;
DH133 AUTOMATIC DROP
HAMMER**

**STATUS: DRAFT
DATE ISSUED:
11/16/2020
REVISION: 1
PAGE 12 of 12**

APPROVALS/CONCURRENCE

By signing this document, all parties acknowledge the completeness and applicability of this SOP for its intended purpose. Also, by signing this document, it serves as acknowledgement that I have received training on the procedure and associated competency testing.

SOP TECHNICAL AUTHOR	DATE
SAFETY AND HEALTH MANAGER	DATE

Revisions:

Revision	Description	Date
1	Updates to SOP to reflect Geoprobe ® Model 7822DT	11/16/2020



**SOP-GEOPROBE-10;
EQUIPMENT DECONTAMINATION -
INORGANIC CONTAMINANTS**

STATUS: DRAFT
DATE ISSUED:
11/16//2020
REVISION: 1
PAGE 1 of 7

PURPOSE	To provide standard instructions for equipment decontamination (inorganic contaminants – heavy metals).
SCOPE	This practice has been prepared for the Pioneer Technical Services, Inc. (Pioneer) workforce and applies to work carried out by and on behalf of Pioneer. All members of the Pioneer workforce who conduct the work shall be trained and competent in the risk-assessed work described below.
NOTES	<p>All equipment leaving the contaminated area of a site must be decontaminated. Decontamination methods include removal of contaminants through physical, chemical, or a combination of both methods. Decontamination procedures are to be performed in the same level of protection used in the contaminated area of a site. In some cases, decontamination personnel may be sufficiently protected by wearing one level lower protection. The information for site specific equipment decontamination and personnel protection levels, as detailed in the Sampling and Analysis Plan (SAP) or work plan, should be followed.</p> <p>The following decontamination procedures are for typical uncontrolled hazardous waste sites. For a specific or unusual contaminant, such as dioxins, see the Site-Specific Health and Safety Plan (SSHASP) and consult with the Safety and Health Manager. Decontamination procedures should be used in conjunction with methods to prevent contamination of sampling and monitoring equipment. If practical, one-time-use equipment should be used, and disposed of in accordance with the SAP, work plan, and SSHASP.</p>

WORK INSTRUCTIONS

The following instructions are intended to provide sufficient guidance to perform the task in a safe, accurate, and reliable manner. Should these instructions present information that is inaccurate or unsafe, operations personnel must bring the issue to the attention of the Project Manager and the appropriate revisions made. All work carried under this SOP will be consistent with procedures and policies described in the appropriate Operation, Maintenance, and Monitoring (O&M) Plan (where applicable), appropriate Site-Specific Health and Safety Plan (SSHASP), and Pioneer Corporate Health and Safety Plan (HASP).

TASK	INSTRUCTIONS
Remove gross contamination.	Remove gross contamination with a tap water rinse. If available, use pressurized or gravity flow tap water. If not, a 5-gallon bucket of tap water and a stiff brush may be used.
Wash equipment.	Wash equipment in a solution of soap (no phosphate) and tap water with a stiff brush.
Triple rinse equipment.	Triple rinse the equipment with tap water. Then, rinse the equipment with de-ionized or distilled water.
Rinse equipment with nitric acid/distilled water mixture.	<p>If specified in the SAP, work plan, or SSHASP, rinse the equipment with a mixture of 10:1 nitric acid in distilled water (10 parts water to 1-part nitric acid). In many cases, the tap water and de-ionized water rinses will be sufficient.</p> <p>If a nitric rinse is used, rinse the equipment again with distilled water.</p>



**SOP-GEOPROBE-10;
EQUIPMENT DECONTAMINATION -
INORGANIC CONTAMINANTS**

STATUS: DRAFT
DATE ISSUED:
11/16//2020
REVISION: 1
PAGE 2 of 7

Air dry equipment.	Place equipment on plastic sheeting or foil to air dry.
Transport/ store equipment.	Wrap equipment in foil or plastic wrap to transport or store.
Triple rinse decontamination equipment.	Triple rinse equipment (i.e., brushes, buckets, tubs, etc.) used in the decontamination process with water, preferably pressurized.
Wash decontamination equipment.	Agitate the equipment used in the decontamination process in the soap/tap water solution. (The tub which holds the solution will only have the water rinse)
Triple rinse decontamination equipment.	Triple rinse equipment with tap water.
Store and label decontamination equipment.	Place equipment in appropriate areas, so they are used only for decontamination purposes. Label the equipment, if necessary.
Dispose of decontamination solutions.	<p>Use a wastewater container to properly dispose of the soap/tap water solution, the tap water rinse, and the de-ionized water rinse.</p> <p>Use an organic solvent waste container to properly dispose of the solvent rinse.</p> <p>When contaminants have been identified, either in the solutions or elsewhere on the site, solutions should be disposed of appropriately as discussed in the SAP, work plan, or SSHASP. If they are hazardous (e.g., characteristic, listed, etc.), dispose of them as such.</p> <p>Note: when using other than the above-mentioned solutions, check with the Safety and Health Manager and the Project Manager. Some solvents must be evaporated.</p>
Measure effectiveness of procedures.	Effectiveness of the decontamination procedures will be measured using field equipment rinsate blanks (see the Site-Specific Quality Assurance Project Plan).



**SOP-GEOPROBE-10;
EQUIPMENT DECONTAMINATION -
INORGANIC CONTAMINANTS**

STATUS: DRAFT
DATE ISSUED:
11/16//2020
REVISION: 1
PAGE 3 of 7

HSSE CONSIDERATIONS

This section to be completed with concurrence from the Safety and Health Manager.

<i>SOURCE</i>	<i>HAZARDS</i>	<i>WHERE</i>	<i>HOW, WHEN, RESULT</i>	<i>CONTROLS</i>
CHEMICAL	Potential contact with contaminated items and resulting water from decontamination procedures.	Sites.	Inadvertent exposure to contaminated items and water resulting from decontamination procedures could lead to adverse health effects.	Personnel will practice proper personal hygiene – wash hands prior to eating/drinking and when leaving the site. Employees will follow decontamination procedures as described above. Employees will wear nitrile gloves when handling contaminated items.
	Nitric acid.	Sites.	Employees could be exposed to nitric acid via ingestion and skin/eye contact when decontaminating equipment. Exposure could cause irritation of skin/eye and dental erosion.	Employees will prevent skin/eye contact with nitric acid and they will wear nitrile gloves and eye protection when handling nitric acid and the nitric acid and distilled water mixture.
NOISE	Not applicable.			
ELECTRICAL	Not applicable.			
BODY MECHANICS	Improper lifting.	Sites.	Back injuries and muscle/back strains could result when using improper techniques to lift decontamination equipment.	Personnel will use proper lifting techniques – get a good grip, hold the load close to the body, lift with the legs and not with the back, and avoid lifting above shoulder height. Use two employees to lift equipment when necessary.
GRAVITY	Slips and falls.	Sites.	Slips and falls could occur while performing decontamination procedures due to slippery surfaces resulting in	Workers will wear work boots with good traction and ankle support. Keep work areas as dry as possible. Wear muck boots, as necessary.



HSSE CONSIDERATIONS

This section to be completed with concurrence from the Safety and Health Manager.

			bruises, scrapes, or broken bones.	
WEATHER	Cold/heat stress.	Outdoors.	Exposure to cold climates may result in cold burns, frostbite, and hypothermia. Exposure to high temperatures may result in heat cramps, heat exhaustion, or heat stroke.	Training on signs and symptoms of cold/heat stress is required. Personnel will wear appropriate clothing when working outdoors (e.g. layers). Employees will remain hydrated and will have sufficient caloric intakes during the day. Personnel will follow procedures outlined in applicable SSHASP and/or Pioneer corporate HASP.
	Lightning.	Outdoors.	Electrocution, injury, death, or equipment damage could be caused by lightning strike.	Employees will follow the 30/30 rule during lightning storms.
RADIATION	Ultraviolet (UV) radiation.	Outdoors.	Employees could be exposed to UV radiation during summer months causing sun burns, skin damage, and eye damage.	Employees will wear sunscreen, long-sleeve work shirts and long pants. Employees will also use safety glasses with tinted lenses.
BIOLOGICAL	Plants, insects, and animals.	Sites	Exposure to plants, insects, and/or animals may cause rashes, blisters, redness, and swelling.	Training on the signs and symptoms of exposure to plants, insects, and animals. Avoid contact with plants, insects, and animals. First-aid kits will be available on site. Employees with allergies will notify their supervisor.
MECHANICAL	Struck by and/or caught in between heavy equipment or	Sites.	Personnel could be injured if struck by and/or caught in	When applicable, employees will communicate with the contact person of other contractors on the site.



**SOP-GEOPROBE-10;
EQUIPMENT DECONTAMINATION -
INORGANIC CONTAMINANTS**

STATUS: DRAFT
DATE ISSUED:
11/16//2020
REVISION: 1
PAGE 5 of 7

HSSE CONSIDERATIONS

This section to be completed with concurrence from the Safety and Health Manager.

	vehicles.		between heavy equipment or vehicles while performing decontamination procedures.	Personnel will avoid working near heavy equipment/vehicles, when possible. High visibility clothing will be worn. When possible, personnel will park field vehicles or use traffic cones to prevent third party vehicles from coming into the work area.
PRESSURE	Not applicable.			
THERMAL	Cold/heat stress. Hypothermia/frostbite.	Sites. Sites where air temperature is 35.6°F (2°C) or less.	Exposure to cold climates may result in cold burns, frostbites, and hypothermia. Exposure to high temperatures may result in heat cramps, heat exhaustion, or heat stroke. Workers whose clothing becomes wet during decontamination procedures may be exposed to hypothermia and/or frostbite.	Training on signs and symptoms of cold/heat stress. Personnel will wear appropriate clothing when working outdoors. Employees will remain hydrated and will have sufficient caloric intakes during the day. Employees will change clothing if it becomes wet.
HUMAN FACTORS	Inexperienced and improperly trained worker.	Sites.	Inexperienced workers and improper training could cause incidents resulting in adverse health effects and/or property damage.	Employees will be properly trained in this procedure and other applicable procedures.



**SOP-GEOPROBE-10;
EQUIPMENT DECONTAMINATION -
INORGANIC CONTAMINANTS**

STATUS: DRAFT
DATE ISSUED:
11/16//2020
REVISION: 1
PAGE 6 of 7

HSSE CONSIDERATIONS
This section to be completed with concurrence from the Safety and Health Manager.

SIMOPS	Not applicable			
---------------	----------------	--	--	--

ADDITIONAL HSSE CONSIDERATIONS
This section to be completed with concurrence from the Safety and Health Manager.

REQUIRED PPE	Safety glasses, high-visibility work shirt or vest, long pants, work boots, and nitrile gloves.
APPLICABLE SDS	SDSs will be maintained based on-site characterization and contaminants. Nitric acid.
REQUIRED PERMITS/FORMS	Per site/project requirements.
ADDITIONAL TRAINING	Per site/project requirements.

DRAWINGS, DOCUMENTS, AND TOOLS/EQUIPMENT
The following documents should be referenced to assist in completing the associated task.

P&IDS	
DRAWINGS	
RELATED SOPs/PROCEDURES/ WORK PLANS	
TOOLS	5-gallon bucket of tap water, stiff brush, soap, de-ionized or distilled water, nitric acid (if required), plastic sheeting or foil, tarps, decontamination tubs and buckets, and sprayers.
FORMS/CHECKLIST	

APPROVALS/CONCURRENCE
By signing this document, all parties acknowledge the completeness and applicability of this SOP for its intended purpose. Also, by signing this document, it serves as acknowledgement that I have received training on the procedure and associated competency testing.

SOP TECHNICAL AUTHOR	DATE
SAFETY AND HEALTH MANAGER	DATE



**SOP-GEOPROBE-10;
EQUIPMENT DECONTAMINATION -
INORGANIC CONTAMINANTS**

**STATUS: DRAFT
DATE ISSUED:
11/16//2020
REVISION: 1
PAGE 7 of 7**

APPROVALS/CONCURRENCE

By signing this document, all parties acknowledge the completeness and applicability of this SOP for its intended purpose. Also, by signing this document, it serves as acknowledgement that I have received training on the procedure and associated competency testing.

--	--

Revisions:

Revision	Description	Date
1	Updates to SOP to reflect Geoprobe ® Model 7822DT	11/16/2020

O'Keefe Drilling Company

Title: GeoProbe Drilling		
		Document No.:GPD5-18
SOP Author/Owner O'Keefe Drilling Company	SOP Approver	Effective Date 5-15-18
Name: Maggie Ryan	Name:	Review Date: none
Signature:	Signature:	Supersedes

1. Purpose

This SOP outlines the steps taken to prepare for Geo Probe Drilling for O'Keefe Drilling Company. This procedure ensures consistency across SOPs.

2. Scope

. This document provides basic application, operation, and safety guideline for use of the Geo Probe Model 8150 LS sampling system. The guidelines apply to use of the sampling system in evaluating subsurface environmental conditions. The document is intended to serve at the Standard Operation Procedure (SOP) for the Geo Probe when used as a site assessment tool. This SOP is intended to supplement the manufacture's guideline on equipment use.

3. Responsibilities

The Driller/Supervisors are responsible for ensuring that their direct reports are following this procedure. Review of the SOP is the responsibility of the SOP author/owner. Other responsibilities are outlined in Section 8. For further information on this SOP, please contact Maggie Ryan/ O'Keefe Drilling at office@okeefedrilling.com

4. Changes Since Last Revision

None

5. Documents/Resources Needed for this SOP

Geo Probe Customer Support Team

Geo Probe 8150 LS Maintenance Manual

6. Definitions

Tramming – moving the GeoProbe

Tripping out- removing drill steel or casing from drilled hole

Break Out Hydraulic Wrench– Wrench found on drill table to make and break connections

O'Keefe Drilling Company

7. Operation

Drilling

Step	Action	Responsibility
1	Perform and machine pre-operation inspection including fluids check before starting the engine.	Driller
2	Turn the key to the on position and start with key or wireless remote. Wait for the machine to run through the cold start sequence if necessary. (Wait for glow plugs to go out after key is turned on before starting)	Driller
3	Make sure all gauges are running at parameters set by the Manufacturer	Driller

TRAMMING

4	Verify operation of emergency stops before moving the machine	
5	Machine must be in transport condition – head lowered and mast folded back onto carrier – before tramping	
6	Operator is to stay clear of the machine when it is in motion. Do not walk or stand between machine and stationary objects while tramping.	

MACHINE SET UP FOR DRILLING

Driller and Helper(s) must wear personal protective equipment appropriate for site conditions to include safety glasses, hard hat, steel toes shoes or boots, and hearing protection designed for noise levels in excess of 100 dB.

Site must be cleared for underground utilities before operation. Verify the drilling location is free of overhead utilities and obstructions.

7	Pivot control panel from transport position our into drilling position	Driller
8	Actuate Outriggers. Make sure the area under the outriggers is clear. Use suitable outrigging pads if necessary. Actuate the outriggers by hold the greend enable button and then the desired outrigger lever.	Driller
9	Tower up the drill mast. Hold the green enable button while actuating the fold control. Use the enable and the mast dump	Driller

O'Keefe Drilling Company

	control to get the drill mast to the desired height. (mast dump need to be fully retracted until the mast is folded out past 45 degrees) Plumb the drill mast using the outriggers.	
10	Turn the sonic head Lube Pump on. lube oil temperature should reach 67 degrees Fahrenheit before operating the sonic head.	Driller

HYDRAULIC ROD HANDLER

Check for obstructions before operating the rod handler.

11	Depress the red enable lever on the joystick before actuating any rod handler function.	Drillers Helper
12	Place drill rod in rod handler and close the jaws. Check that the rod is seated correctly in the jaws to avoid dropping the rod	Drillers Helper
13	Move the rod up into position and then align the rod to the spindle using the "wrist" function of the rod handler.	Driller and Drillers Helper
14	Thread onto the rod and confirm that the spindle is connected to the rod before retracting the rod handler jaws.	Driller and Drillers Helper
15	Attach drill bit and pre-assembled core catcher to the terminal end of the drill stem using the breakout hydraulic wrench	Drillers Helper

WINCH OPERATION

16	Rotate winch into position. This positioning function does not require the use of the enable button.	Driller
17	Watch for obstructions (drill head, hoses, etc...) when winching up or down	Driller
18	Keep tension on the winch cables when winching up or down to prevent tangles on the spool.	Driller
19	Examine wire rope connection and check for kinks or frays. Replace any worn wire rope with the appropriate replacement.	Driller
20	Rotate winch back into transport position before folding the mast into transport position.	Driller

8. PRECAUTIONS

- Read and understand all safety, maintenance, and operation instructions in this owner's manual before operating the Geoprobe® Model 8150LS.
- Refer to the CATERPILLAR® C7.1 Industrial Engine Operation and Maintenance Manual for engine-related safety instructions before operating the machine.

O'Keefe Drilling Company

- Heed all CAUTION, WARNING, and DANGER decals posted on the machine.
- Do not wear loose clothing while operating this machine. Severe injury will result if clothing becomes entangled in moving parts.
- Operators must wear OSHA-approved steel-toed shoes or boots and keep feet clear of drill mast base.
- Operators must wear OSHA-approved safety glasses at all times during the operation of this machine.
- Always wear hearing protection designed for noise levels in excess of 100 dB when operating the 8150LS.
- There are three emergency stop (E-stop) buttons for the Model 8150LS. Pushing any of the buttons will immediately shut off the engine and deactivate the electrical system. Operators must be familiar with the location and proper use of these safety devices before starting the machine.
- Check all emergency stops for proper operation at the beginning of each work shift and after tramming (moving or driving the machine). Do not operate the machine unless all E-stops are functioning properly.
- Forms are provided to assist with daily checks/inspections of the machine and the wireless remote control system. It is recommended that these inspections are performed each day before work.
- Engine exhaust fumes are toxic and may not be detectable by smell. Provide adequate ventilation to conduct engine exhaust away from personnel if working in a confined area. If there is any question as to the air quality of the work site, equipment for monitoring atmospheric conditions must be employed.
- Ensure that everyone is clear of all moving parts before starting the engine.
- Check that all outriggers are raised before attempting to drive the unit.
- Maximize stability by placing the machine in the transport condition (head lowered and drill mast folded back onto carrier) before driving.
- Do not drive the machine in the working condition with the hammer raised or optional winch mast extended. This practice could result in equipment damage and/or personal injury from contact with overhead objects such as power lines.
- The unit must only be driven using the remote control transmitter or tethered paddle box. The track controls located on the machine control panel are for positioning (short

O'Keefe Drilling Company

movements) only. When driving, maintain sufficient distance from the machine to avoid injury in case of tripping or sudden change in direction of machine movement.

- Do not operate the machine on excessive slopes. Ultimately, it is the responsibility of the operator to determine if site conditions are safe.
- When driving on a sloped surface, go straight up or down grade whenever possible. Avoid sideslopes. Place the unit parallel with the slope and with the control panel uphill when working.
- Place the remote control system in low speed mode to obtain the most precise control of machine movement.
- Designate one person to operate the machine controls to avoid injuries from unexpected machine movements.
- Operators must stand to the control panel side of the machine while operating the controls. Never reach across the drill mast to manipulate the machine controls.
- In the event of a problem, the operator should release all controls. The spring-loaded controls will automatically return to the neutral position and machine operation will cease unless the optional hands-free detent function is active. If an unsafe condition occurs, immediately shutdown the machine by pressing one of the E-stop buttons.
- Avoid crushing injuries - keep away from the optional breakout assembly when opening or closing the clamps.
- Never move the drill mast or head or operate the tracks while anyone is in physical contact with the tool string.
- Always place the drill mast and front outriggers firmly on the ground when pulling tools from the subsurface.
- Use caution when working on loose or soft surfaces. Reduced weight on the tracks may allow the unit to shift or slide under such conditions.
- Do not directly grasp the wire rope of a hydraulic winch. Only grasp the tool string or winch hook below the swivel to avoid injury if the wire rope spins or there are frayed wires on the rope.
- Rotating parts can cause serious injuries. Place the engine ignition and master disconnect switches in the "Off" position and remove the keys before attempting to clean or service the unit.
- Avoid hydraulic fluid leaks. Pressurized fluid may be injected into the skin resulting in serious bodily injury. In the event of an accident, seek medical attention immediately.

O'Keefe Drilling Company

- Maintain engine compartment latches in the locked position to avoid unauthorized access and possible accidental injuries.
- Do not make modifications or add attachments to this machine which are not approved by Geoprobe Systems®.

9. Records

An electronic copy of this document is stored at O'Keefe Drilling Company's main office at 2000 Four Mile Road in Butte, MT 59701. A paper copy of this document is available on site in the Drillers Manual.



MODERNWATER

RaPID Assay® PCP Test Kit

A00111

Intended Use

The RaPID Assay® Pentachlorophenol (PCP) Test Kit can be used as a quantitative, semi-quantitative or qualitative enzyme immunoassay (EIA) for the analysis of pentachlorophenol in water (groundwater, surface water, well water). For applications in other matrices please contact our Technical Service department. The RaPID Assay® Pentachlorophenol Test Kit allows reliable and rapid screening for pentachlorophenol and related compounds, with quantitation between 0.25 ppb and 10 ppb. The minimum detection level of the kit is 0.06 ppb.

Test Principles

The Pentachlorophenol RaPID Assay® kit applies the principles of enzyme linked immunosorbent assay (ELISA) to the determination of pentachlorophenol and related compounds. The sample to be tested is added, along with an enzyme conjugate, to a disposable test tube, followed by paramagnetic particles with antibodies specific to pentachlorophenol attached. Both pentachlorophenol (which may be in the sample) and the enzyme labeled pentachlorophenol (the enzyme conjugate) compete for antibody binding sites on the magnetic particles. At the end of an incubation period, a magnetic field is applied to hold the paramagnetic particles (with pentachlorophenol and labeled pentachlorophenol analog bound to the antibodies on the particles, in proportion to their original concentration) in the tube and allow the unbound reagents to be decanted. After decanting, the particles are washed with Washing Solution.

The presence of pentachlorophenol is detected by adding the enzyme substrate (hydrogen peroxide) and the chromogen (3,3',5,5' – tetramethylbenzidine). The enzyme labeled pentachlorophenol analog bound to the pentachlorophenol antibody catalyzes the conversion of the substrate/chromogen mixture to a colored product. After an incubation period, the reaction is stopped and stabilized by the addition of acid. Since the labeled pentachlorophenol (conjugate) was in competition with the unlabeled pentachlorophenol (sample) for the antibody sites, the color developed is inversely proportional to the concentration of pentachlorophenol in the sample.

NOTE: Color development is inversely proportional to the pentachlorophenol concentration.

Darker color = lower concentration

Lighter color = higher concentration

The determination of the pentachlorophenol level in an unknown sample is interpreted relative to the standard curve generated from kit standards after reading with a spectrophotometer.

Performance Characteristics

The Pentachlorophenol RaPID Assay® will detect different pentachlorophenol and related compounds to different degrees. Refer to the table below for data on several of these. The Pentachlorophenol RaPID Assay® kit provides screening results. As with any analytical technique (GC, HPLC, etc.), positive results requiring some action should be confirmed by an alternative method.

The Pentachlorophenol RaPID Assay® immunoassay test does not differentiate between pentachlorophenol and other related compounds. The table below shows compounds at the method detection limit (MDL) which is the lowest concentration of the compound, in water, that can be picked up in the assay. The limit of quantitation (LOQ) is an approximate concentration, in water, required to yield a positive result at the lowest standard. **This is the lowest concentration of the compound that can be quantified in the assay.** The IC50 is the concentration required to inhibit one half of the color produced by the negative control. It is also used to calculate cross-reactivity values to similar compounds.

Compound	MDL (ppb)	LOQ (ppb)	IC50 (ppb)
Pentachlorophenol	0.06	0.25	2.20
2,3,5,6-Tetrachlorophenol	0.21	0.184	4.06
2,3,4,6-Tetrachlorophenol	0.91	0.66	14.6
2,3,5-Trichlorophenol	1.52	5.4	119
2,3,6-Trichlorophenol	2.44	2.86	62.9
Tetrachlorohydroquinone	8.70	6.73	148
2,4,6-Trichlorophenol	15.1	21.0	463
2,4,5-Trichlorophenol	21.5	26.1	574
2,3,4-Trichlorophenol	53.2	78.6	1730
2,5-Dichlorophenol	62.9	356	7830
2,6-Dichlorophenol	266	272.3	5990
2,3-Dichlorophenol	611	>611	>10000
2,4-Dichlorophenol	887	>887	>10000
3,5-Dichlorophenol	1670	>1670	>10000
Hexachlorobenzene	1560	>1560	>10000
Hexachlorocyclohexane	5790	>5790	>10000

*The following compounds demonstrated no reactivity in the Pentachlorophenol RaPID Assay® test kit at concentrations up to 10 ppm: alachlor, aldicarb, benomyl, butachlor, butylate, captan, carbaryl, carbendazim, carbofuran, 4-chlorophenol, 3,4-dichlorophenol, chlorothalonil, 2,4-D, 1,3-dichloroproprne, dinoseb, MCPA, metalaxyl, metolachlor, metribuzin, pentachlorobenzene, pentachloronitrobenzene, picloram, propachlor, terbufos, thiabendazole, and thiophanate-methyl.

The presence of the following substances up to 250 ppm were found to have no significant effect on Pentachlorophenol RaPID Assay® results: calcium, copper, manganese, magnesium, mercury, nickel, nitrate, phosphate, sulfite, thiosulfate and zinc. In addition, sodium chloride up to 0.65 M, sulfate to 10,000 ppm, iron to 50 ppm and humic acid to 10 ppm, showed no specific effect on results.

Precautions

- Training is strongly recommended prior to using the RaPID Assay® test system. Contact Modern Water for additional information.
- Treat pentachlorophenol, solutions that contain pentachlorophenol, and potentially contaminated samples as hazardous materials
- Use gloves, proper protective clothing, and methods to contain and handle hazardous material where appropriate.
- Reagents must be added in a consistent manner to the entire rack. A consistent technique is the key to optimal performance. Be sure to treat each tube in an identical manner.
- Water samples should be at a neutral pH prior to analysis. Samples containing gross particulate should be filtered (e.g. 0.2 um Anotop™ 25 Plus, Whatman, Inc.) to remove particles.
- Store all test kit components at 2°C to 8°C (36°F to 46°F). Storage at ambient temperature (18°C to 27°C or 64°F to 81°F) on the day of use is acceptable. *Test tubes require no special storage and may be stored separately to conserve refrigerator space.*
- Allow all reagents to reach ambient temperature (18°C to 27°C or 64°F to 81°F) before beginning the test. This typically requires at least 1 hour to warm from recommended storage conditions.
- Do not freeze test kit components or expose them to temperatures above 100°F (39°C).
- Do not use test kit components after the expiration date.
- Do not use reagents or test tubes from one test kit with reagents or test tubes from a different test kit.
- Do not mix reagents from kits of different lot numbers.
- Use approved methodologies to confirm any positive results.
- Do not under any circumstances attempt to disassemble the base of the magnetic rack. Magnets will be violently attracted to each other.
- Adequate sample number and distribution are the responsibility of the analyst.
- The photometer provided in the accessory kit requires electricity and comes with a 110V adapter. Adapters for 220V are available.
- Do not expose color solution to direct sunlight.
- Do not dilute or adulterate test reagents or use samples not called for in the test procedure; this may give inaccurate results.
- Tightly recap the standard vials when not in use to prevent evaporative loss.

Materials Provided

- Antibody Coupled Paramagnetic Particles in buffered saline containing preservative and stabilizers.
100 test kit: one 65 mL vial
- Enzyme Conjugate.
100 test kit: one 35 mL vial
- Standards
Three concentrations (0.25, 2.0 and 10.0 ppb) of pentachlorophenol standards in buffered saline containing preservative and stabilizers are supplied. Each vial contains 4 mL.
- Control
A concentration (approximately 1 ppb) of pentachlorophenol in buffered saline containing preservative and stabilizers. A 4 mL volume is supplied in one vial.
- Diluent/Zero Standard
Buffered saline containing preservative and stabilizers without any detectable pentachlorophenol.
100 test kit: one 35 mL vial
- Color Solution containing hydrogen peroxide and 3,3',5,5'-tetramethylbenzidine in an organic base.
100 test kit: one 65 mL vial
- Stop Solution containing a solution of 2M sulfuric acid.
100 test kit: one 60 mL vial
- Washing Solution containing buffered saline with preservatives and stabilizers.
100 test kit: one 250 mL vial
- Polystyrene test tubes
100 test kit: one box 108 tubes
- User's Guide

Materials Required and Ordered Separately

See "Ordering Information" for the appropriate catalogue numbers.

Rapid Assay® Accessory Kit

Accessory equipment may be rented or purchased from Modern Water. See "Ordering Information" for the appropriate catalogue numbers.

The accessory kit contains the following items:

- Adjustable Volume Pipet
- Eppendorf™ Repeater® Pipettor

- Electronic timer
- Portable balance capable of weighing 10 g (for soil samples)
- Vortex mixer
- Magnetic separation rack
- RPA-II RaPID Analyzer (or equivalent spectrophotometer capable of reading 450 nm in a 1 mL sample size).

Other Items

- 12.5 mL Combitips[®] for the Repeater pipettor - for 0.25 mL to 1.25 mL dispensing volumes (5)
- Pipet tips for adjustable volume pipet (100-1000 uL)

NOTE: Order replacement Combitips[®] and pipet tips separately. See the "Ordering Information" section.

Materials Required but Not Provided

- Protective clothing (e.g., latex gloves)
- Absorbent paper for blotting test tubes
- Liquid and solid waste containers
- Marking pen

Suggestions for Pipettor Use

- Practice using both pipettes (adjustable volume and Repeater pipettor) with water and extra tips before you analyze your samples.
- Use a new tip each time you use the Repeater pipettor to pipette a different reagent to avoid reagent cross-contamination. Tips can be rinsed thoroughly, dried completely and reused. By using the same tip to dispense the same reagent each time you can avoid cross contamination.

NOTE: Repeater tips should be changed periodically (after ~10 uses) since precision deteriorates with use.

- Draw the desired reagent volume into the Repeater pipettor and dispense one portion of the reagent back into the container to properly engage the ratchet mechanism. If you do not do this, the first volume delivered may be inaccurate.
- To add reagents using the Repeater pipettor, pipette down the side of the test tube just below the rim.
- When adding samples and standards using the positive displacement pipettor, always pipette into the bottom of the tube without touching the sides or bottom of the tube.
- Use a new adjustable volume pipet tip each time you pipette a new unknown.

Assay Procedure

Prior to performing your first Rapid Assay®, please take time to read the package inserts in their entirety. **On site training is strongly recommended for new users of this test system.** Please contact your account manager for further information. This procedure is designed for quantitative analysis. For running the kit semi-quantitatively or qualitatively, please contact Technical Support.

Collect/Store the Sample

The following steps explain how to properly collect and store your samples.

1. Water samples should be collected in glass vessels with teflon cap liners.
2. Samples should be collected in appropriately sized and labeled containers.
3. If testing soil samples, follow the MWI Sample Extraction Kit User's Guide or the appropriate technical bulletin to properly collect and store your sample.
4. Samples should be tested as soon as possible after collection. If this is not possible, storage at 4°C (39°F) is recommended to minimize evaporative losses.

Set Up

1. Remove kits from refrigerator. All reagents must be allowed to come to room temperature prior to analysis. Remove reagents from packaging and place at room temperature at least 1 hour prior to testing.
2. Turn on the RPA-II or other spectrophotometer. The RPA-II should be warmed up for at least 30 minutes prior to the run.
3. Label five 12.5 mL Combitips "Conjugate", "Particles", "Wash", "Color" and "Stop". In addition, add the name of the compound you are testing for to each Combitip.
4. Remove nine clean blank test tubes for standards and control and one test tube for each sample (if testing in singlicate). Label the test tubes according to contents as follows.

<u>Tube #</u>	<u>Contents</u>
1	Negative control (Diluent/Zero Standard) (replicate 1)
2	Negative control (Diluent/Zero Standard) (replicate 2)
3	Standard 1 (replicate 1)
4	Standard 1 (replicate 2)
5	Standard 2 (replicate 1)
6	Standard 2 (replicate 2)
7	Standard 3 (replicate 1)
8	Standard 3 (replicate 2)
9	Control
10	Sample 1
11	Etc.

***Label at top of tubes to avoid interference with reading of tubes in photometer**

Sample Extraction and Dilution

Water samples being tested at standard kit detection levels do not require dilution. Filtration may be necessary to remove gross particulate from the water sample. If testing samples at levels higher than standard kit level is desired, contact MWI for special instructions. Please follow the instructions from the MWI Sample Extraction Kit to prepare and dilute the soil extract prior to running the assay

Perform the Test

1. Separate the upper rack from the magnetic base. Place labeled test tubes into the rack.
2. Add **200 uL** of standards, control or samples to the appropriate tubes using the adjustable volume pipet with the dial set on **0200**. The negative control, standards and control must be run with each batch of samples.

NOTE: Sample should be added to the bottom of the tube by inserting the pipet tip into the tube without touching the sides or the bottom of the tube. Take care not to contact sample with pipette tip once dispensed into bottom of the tube.

3. Using the Repeater Pipettor with the “Conjugate” tip attached and the dial set on “**1**”, add **250 uL** of Enzyme conjugate down the **inside wall** of each tube. (Aim the pipet tip $\frac{1}{4}$ ” to $\frac{1}{2}$ ” below the tube rim or tube wall; deliver liquid gently to avoid splashback.)
4. Thoroughly mix the magnetic particles by swirling (avoid vigorous shaking) and attach the “Particles” tip to the Repeater Pipettor. With the dial set on “**2**” add **500 uL** of magnetic particles to each tube, aiming down the side of the tube as described above. Vortex, mixing each tube 1 to 2 seconds at low speed to minimize foaming. Pipetting of magnetic particles should be kept to 2 minutes or less.
5. Incubate 30 minutes at room temperature.
6. After the incubation, combine the upper rack with the magnetic base and press all tubes into the base; allow 2 minutes for the particles to separate.
7. With the upper rack and magnetic base combined, use a smooth motion to invert the combined rack assembly over a sink and pour out the tube contents.

NOTE: If the rack assembly inadvertently comes apart when lifting to pour out tube contents, re-combine and wait an additional 2 minutes to allow particles to separate.

8. **Keep the rack inverted** and gently blot the test tube rims on several layers of paper towels. It is important to remove as much liquid as possible but **do not bang** the rack or you may dislodge the magnetic particles and affect the results.
9. Set the Repeater Pipettor dial to “**4**” and put on the tip labeled “Wash”. Add **1 mL** of Washing Solution down the inside wall of each tube by using the technique described earlier. Vortex tubes for 1-2 seconds. **Wait 2 minutes** and pour out the tube contents as described previously. **Repeat this step one more time.**

NOTE: The number of washes and wash volume are important in ensuring accurate results.

10. Remove the upper rack (with its tubes) from the magnetic base. With the “Color” tip attached to the Repeater Pipet and the dial set to “2” add **500 uL** of Color Reagent down the inside wall of each tube as described previously. Vortex 1 to 2 seconds (at low speed).
11. Incubate 20 minutes at room temperature. During this period, add approximately 1 mL of Washing solution to a clean tube for use as an instrument blank for “Results Interpretation”.
12. After the incubation, position the Repeater pipettor at Setting “2” and use the “Stop” tip to add **500 uL** of Stop solution to all test tubes.
13. Proceed with results interpretation.

WARNING: Stop solution contains 2M sulfuric acid. Handle carefully.

Results Interpretation

1. After addition of Stop Solution to the test tubes, results should be read within 15 minutes.
2. Wipe the outside of all antibody coated tubes prior to photometric analysis to remove fingerprints and smudges.

Photometric Interpretation Using the RPA-II

1. The RPA-II photometer (provided in the Rapid Assay® Accessory kit) can be used to calculate and store calibration curves. It is preprogrammed with various RaPID Assay® protocols. To obtain results from the Pentachlorophenol Rapid Assay® test kit parameters are as follows:

Data Reduct:	Lin. Regression
Xformation:	Ln/LogitB
Read Mode:	Absorbance
Wavelength:	450 nm
Units :	PPB
# Rgt Blk :	0

Calibrators:	
# of Cals :	4
# of Reps :	2

Concentrations:	
#1:	0.00 ppb
#2:	0.25 ppb
#3:	2.00 ppb
#4:	10.00 ppb

Range: 0.06 – 10.00
 Correlation: 0.990
 Rep. %CV: 10%

NOTE: Prior to analysis the RPA-II User's Manual should be thoroughly reviewed for more detailed operation instructions.

2. Follow the instrument prompts to read the absorbance of all tubes:

<u>Instrument Display</u>	<u>Operator Response</u>
SELECT COMMAND	Press RUN
RUN PROTOCOL	Scroll using the YES <input type="checkbox"/> or NO <input type="checkbox"/> keys until the desired protocol appears. Then press ENTER
SPL. REPLICATES (1-5)	Press 1 (for analysis of samples in singlicate.) Press ENTER
BLANK TUBE, INSERT TUBE, EVALUATING TUBE	Insert blank tube containing 1mL wash solution.
REMOVE TUBE (Beep)	Remove tube
CAL #1, REP. #1, INSERT TUBE, EVALUATING TUBE	Insert Tube #1
REMOVE TUBE (Beep)	Remove tube

Follow prompts to read all tubes.

NOTE: Tube order is important. The RPA-II expects to see the standards in ascending order, in duplicate, starting with the negative control.

Following evaluation of all standards, the instrument will display:

PRINTING DATA	Data will print
PRINTING CURVE	Curve will print
CTRL #1 REP #1, INSERT TUBE, EVALUATING TUBE	Insert Control Tube
REMOVE TUBE (Beep)	Remove Tube

EDIT CALIBRATORS	Press NO (if editing is necessary press YES and refer to the RPAII User's Manual).
SPL # REP# INSERT TUBE EVALUATING TUBE	Insert first sample tube
REMOVE TUBE (Beep)	Remove tube

Continue to follow prompts. After all samples have been read, press STOP.

Expected Results:

- **%CV (coefficient of variation) between standard duplicates of 10% or less.**
- **Absorbance reading for the 0 ppb standard should be between 0.8 and 2.0 for all assays.**
- **Correlation (r) of 0.990 or greater for all assays.**
- **Kit control within range specified on vial.**
- **Absorbance of negative control and standards should be as follows:**

Negative Control > Std. 1 > Std. 2 > Std. 3.

3. Concentrations will be indicated for all samples on the RPA-II printout.
 - a) The concentration, as indicated on the printout, is multiplied by the appropriate dilution factor (if applicable) introduced in the procedure. The quantitation range of the kit is also multiplied by this factor.
 - b) Samples with an “nd” and no concentration listed have an absorbance greater than the negative control; therefore, no concentration can be computed for these samples. Results must be reported as < 0.1 ppb (Standard 1).
 - c) Samples with an “nd” next to a listed concentration have an estimated concentration below the minimum detection level of the test kit. Results must be reported as <0.1 ppb (or Standard 1).

NOTE: Any samples with concentrations determined to be lower than Standard 1 (the limit of quantitation) must be reported as < 0.1 (or Standard 1). Quantitation is not possible below this standard as this is outside the linear range of the assay.

- d) Similarly, samples with a “hi” next to a listed concentration have an estimated concentration higher than Standard 3 and must be reported as >10 ppb (or Standard 3).

NOTE: In order to determine the concentration of samples with concentrations greater than Standard 3, they must be subjected to repeat testing using a diluted sample. A ten-fold or greater dilution of the sample is recommended with an appropriate amount of pentachlorophenol diluent. This additional dilution must then be taken into account when calculating the concentration. Please contact Technical Support for assistance in performing dilutions.

Photometric Interpretation Using Other Photometers

Other photometers may also be used to interpret results obtained from the RPA-II photometer. It is important that the photometer be able to read absorbance at 450nm and that the instrument can read at a 1 mL fill volume. Absorbances obtained from other spectrophotometers (reading at 450 nm) may be used to manually calculate sample concentrations as outlined below.

1. Calculate the mean absorbance for each of the three standards and the negative control.
2. Determine the standard deviation and %CV (coefficient of variation) of each standard and ensure %CV is less than 10% for each.
3. Calculate the %B/Bo for each standard by dividing the mean absorbance value for the standard by the mean absorbance value for the negative control and multiplying the results by 100.
4. Construct a standard curve by plotting the %B/Bo for each standard on the vertical logit (y) axis versus the corresponding analyte concentration on the horizontal logarithmic (x) axis on the graph paper provided in the test kit. **Graph papers are specific for each method. Use only the graph paper supplied with each kit.**
5. Draw the best straight line through all points. Using the %B/Bo of the sample, the concentration can be interpolated from the standard curve.
6. Multiply results by the appropriate dilution factor (if applicable) introduced in the procedure. For example, if the sample was diluted 10-fold to increase the detection levels of the kit then the results must be multiplied by 10. This dilution also changes the range of the assay (standards) by the same factor.

Limitations of the Procedure

The Rapid Assay® Pentachlorophenol Test Kit is a screening test **only**. Sampling error may significantly affect testing reliability. Adequate sample number and distribution are the responsibility of the analyst.

Ordering Information

Description	Catalogue Number
Rapid Assay® Pentachlorophenol Test Kit	A00111
Rapid Assay® Accessory Kit**	6050100
Adjustable Volume Pipet Tips (100-1000 uL)	A00013
12.5 mL Combitip for Repeating Pipette (1 each)	A00009
Pentachlorophenol Diluent	A00113
Rapid Assay® Rental Accessory Kit	6997010
** To obtain part numbers and pricing for individual items in the Accessory Kit contact MWI at the number below.	

Ordering/Technical Assistance

Should you have any questions regarding this procedure prior to analysis, contact Technical Service to avoid costly mistakes.

To Place an Order or Receive Technical Assistance, please call Modern Water Inc. at:

Toll-free **(855) 637-6426**
 Or (302) 669-6900 Phone
 877-766-3944 Fax
 www.modernwater.com

General Limited Warranty

Modern Water's products are manufactured under strict quality control guidelines and are warranted to be free from defects in materials and workmanship. New instruments and related non-expendable items are warranted for one year from date of shipment against defective materials or workmanship under normal use and service.

Warranty obligation is limited to repair or replacement of the defective product or to refund of the purchase price, at the discretion of Modern Water. Other warranties, express or implied, are disclaimed. Modern Water's liability under any warranty claim shall not exceed the refund of the purchase price paid by the customer. Under no circumstances shall Modern Water be liable for special, indirect or consequential damages.

Safety

To receive an MSDS for this product, visit our web site at www.modernwater.com.

Copyright© 2012, Modern Water Inc.



MODERNWATER

Operation of the Repeater Pipet

To Set or Adjust Volume

To determine the pipetting volume, the dial setting (1-5) is multiplied by the minimum pipetting volume of the tip (indicated on the side of the Combitip, e.g. 1-100 uL.)

To Assemble Pipet Tip

Slide filling lever down until it stops. Then raise the locking clamp and insert the tip until it clicks into position. Be sure the tip plunger is fully inserted into the barrel before lowering the locking clamp to affix the tip in place.

To Fill Tip

With tip mounted in position on pipet, immerse end of tip into solution. Slide filling lever upward slowly. Combitip will fill with liquid.

To Dispense Sample

Check the volume selection dial to ensure pipetting volume. Place tip inside test tube so that tip touches the inner wall of tube. Completely depress the pipetting lever to deliver sample. NOTE: Dispense one portion of reagent back into the container to engage the ratchet mechanism and ensure accuracy.

To Eject Tip

Empty tip of any remaining solution into appropriate container by pushing filling lever down. Raise locking clamp upward, and remove the Combitip.

Operation of the Adjustable Volume Pipet

To Set or Adjust Volume

Press release button on side of pipette and turn the push-button to adjust volume up or down. Volume setting is displayed on top of pipet. See kit instructions for appropriate setting. Pipet will accurately dispense volumes between 100 and 1000 uL.

To Assemble Pipet Tip

Gently push nose cone of pipet firmly into a pipet tip contained in the pipet tip rack.

To Withdraw Sample

Keep pipet almost vertical. With tip mounted in position on pipet, press push-button to 1st stop and hold it. Place tip at bottom of liquid sample and slowly release push-button to withdraw measured sample. Ensure that no air bubbles exist in the pipette tip. If bubbles exist, dispense sample and re-withdraw. Slide tip out along the inside of the vessel.

To Dispense Sample

Wipe any liquid from outside of tip taking care not to touch orifice. Place tip into tube, almost to the bottom, and slowly press push-button to 2nd stop. Hold push-button at 2nd stop when removing tip from tube.

To Eject Tip

Press push-button to 3rd stop. Tip is ejected.

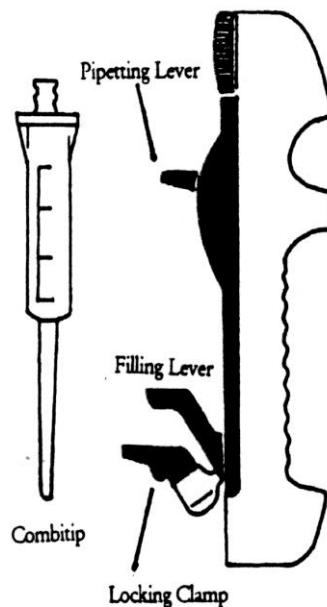
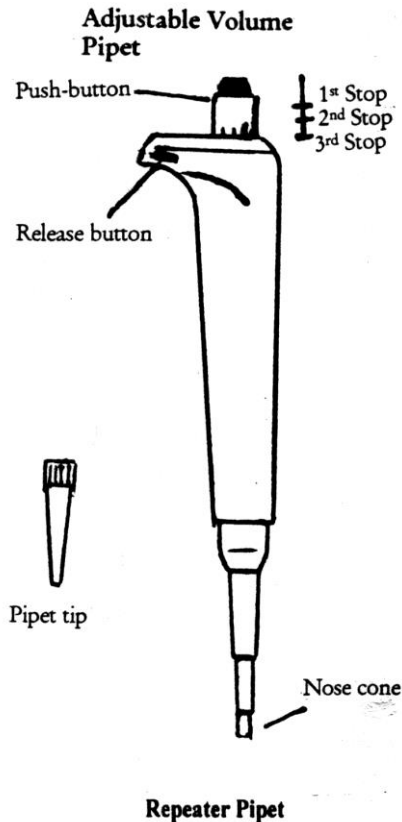



SOP-S-03;
SEDIMENT SAMPLING FROM
STREAMS, PONDS, AND LAKES

DATE ISSUED:
 12/11/2014
REVISION: 0
PAGE 1 of 8

PURPOSE	To provide standard instructions for sediment sampling from stream, ponds, and lakes.
SCOPE	This practice has been prepared for the Pioneer Technical Services, Inc. (Pioneer) workforce and applies to work carried out by and on behalf of Pioneer. All members of the Pioneer workforce who conduct the work shall be trained and competent in the risk-assessed work described below.
GUIDELINES FOR SAMPLE COLLECTION	<p>Sediments can be used to help locate nonpoint, historical or intermittent contaminant discharges that may not be readily apparent using samples collected from surface water. Sediments can be used to help identify these discharges by collection of samples upstream and downstream of potential source areas.</p> <p>The chemical and physical nature of sediments is strongly influenced by the size of the individual particles of sediment. Sediments composed of sands and larger sized particles are often stable inorganic silicate minerals. These types of materials are usually not associated with contaminants and are not recommended for analysis. Fine grained silts and clays are generally much more chemically, physically and biologically interactive. These are the types of sediments that should be submitted for analysis and most of the sediment sampling locations should be biased towards collecting these types of sediments. Fine grained sediments may be located in areas of slower water, behind large rocks or obstructions, or in bends of a stream. Sampling in areas of aquatic vegetation, where macrophyte roots or other vegetation may be collected, should be avoided.</p> <p>The time of year when samples will be collected should be considered during the planning of sampling activities. In general, sediment sampling during low flow conditions of summer and fall are the most practical and safe.</p> <p>If the sediment sampling locations are located within a short distance of each other, then the most downstream sample should be collected first to avoid contamination from disturbance and resuspension of sediment due to sampling activities. Results of headspace analysis can also be used to help locate sampling sites.</p>
NOTE	Very simple techniques can usually be employed for sediment sampling. Most samples will be grab samples, although sometimes sediment taken from various locations may be combined into one sample to reduce the amount of laboratory support required.



SOP-S-03;
SEDIMENT SAMPLING FROM
STREAMS, PONDS, AND LAKES

DATE ISSUED:
 12/11/2014
REVISION: 0
PAGE 2 of 8

WORK INSTRUCTIONS

The following instructions are intended to provide sufficient guidance to perform the task in a safe, accurate, and reliable manner. Should these instructions present information that is inaccurate or unsafe, operations personnel must bring the issue to the attention of the Project Manager and the appropriate revisions made. All work carried under this SOP will be consistent with procedures and policies described in the appropriate Operation, Maintenance, and Monitoring (O&M) Plan (where applicable), appropriate Site-Specific Health and Safety Plan (SSHASP), and Pioneer Corporate Health and Safety Plan (HASP).

TASK	INSTRUCTIONS
Labeling Sample Bottles	
1. Label sample bottle(s).	Prior to commencing sampling activities, label the sample bottle(s) with the appropriate sample number. Carefully and clearly address all the required categories and parameters. Place clear tape over the label. Record sampling information in the logbook, on field data sheets, and on the chain-of-custody forms.
Collection of Shallow Depth Sediments	
Note	<p>In small, low flowing streams, mouths of culverts or near the shore of a pond or lake, a disposable plastic scoop or clean stainless steel spoon or trowel may be used to collect sediments directly into the sample container.</p> <p>If multiple sample containers need to be filled at a sample location, a clean disposable foil pan, a clean stainless steel bowl or a large plastic Ziploc bag can be used to place sediments in as they are collected.</p>
1. Decant water from the sample.	Decant as much water as possible from the sample prior to placement into the sample container or collection pan, bowl or bag. Avoid losing extremely fine material from the sample, during decanting.
2. Collect the sample from more than one location.	<p>Unless specified in the Sampling and Analysis Plan (SAP) or work plan, collect the sample from more than one location at the sample site to make sure that different depositional areas are represented (e.g., behind several different rocks, material from upstream portion of sand bar, middle of sand bar, downstream end of sand bar, etc.).</p> <p>While wading in shallow water, stand on the downstream side of the collection site and work upstream. Care should be taken to create the least disturbance to the sampling site as possible especially from wading or disturbance of the sediment from currents induced by wading.</p>
3. Fill the sample bottles.	<p>Once enough sediment has been placed in the collection container to fill the sample bottles, thoroughly mix the sample with the sampling tool.</p> <p>Remove all stones, shells, detritus, roots and other foreign matter from the sample using the sampling tool or a gloved hand.</p> <p>Place the sediment into appropriate containers. Mix the sample continuously to prevent stratification of the sample.</p>



SOP-S-03;
SEDIMENT SAMPLING FROM
STREAMS, PONDS, AND LAKES

DATE ISSUED:
 12/11/2014
REVISION: 0
 PAGE 3 of 8

4. Collect samples for the analysis of VOCs.	Samples for the analysis of volatile organic compounds (VOCs) should not be composited or homogenized. Collect samples for the analysis of VOCs first and pack them to exclude as much air space as possible. Surficial water from the sediment sample may be added to exclude all air. Fill containers according to the following sequence: grab samples for VOC analysis first, followed by composite samples for semi-volatiles, pesticides /PCBs, nutrients, metals, and particle size.
5. Collect composite samples, if needed.	<p>If a composite sample is needed, note the number of grab samples collected for the composite in the field logbook. Place subsamples (grabs), of equal volumes, in a new foil pan, a cleaned stainless steel bowl or Ziploc bag. When all grab samples have been collected, thoroughly mix the sample with the sampling tool.</p> <p>Remove all stones, shells, detritus, roots and other foreign matter from the sample using the sampling tool or a gloved hand.</p> <p>Place the sediment into appropriate containers. Mix the sample continuously to prevent stratification of the sample.</p>
6. Pack and store the samples.	Once filled, wipe off the sample containers. Place the sample containers in individual Ziploc bags to prevent cross contamination, to keep the container clean, dry, and isolated, and to protect the sample label. Place the sample containers in a cooler and store them at 4°C or less. Record appropriate information about the sample and collection activities in the field logbook.
7. Decontaminate the equipment.	Clean all non-disposable sampling tools prior to moving to the next sample site according to procedures outlined in SOP-DE-02 Equipment Decontamination or in the SAP or work plan.

Collection of Sediments from Deeper Bodies of Water

1. Sample collection from larger streams or farther from the shore of a pond or lake.	<p>To obtain sediments from larger streams or farther from the shore of a pond or lake, a Teflon beaker or disposable plastic scoop attached to a telescoping pole by means of a clamp may be used to dredge sediments.</p> <p>Care should be taken when the scoop is raised through the water column or is passed through a river current during retrieval to minimize the loss of extremely fine material.</p> <p>One composite sample or a number of grab sediment samples should be collected along a cross-section of a larger river or stream in order to characterize the bed material adequately. A common practice is to sample at quarter points along the cross-section of the site selected. Sample collection should follow those procedures discussed in the Collection of Shallow Depth Sediments section above.</p>
2. Sample collection from rivers or in deeper lakes and ponds.	To obtain sediments from rivers or in deeper lakes and ponds, a spring loaded sediment dredge or benthic sampler may be used by lowering the sampler to the appropriate depth with a rope. Collection of the sample should follow the instructions in the devices operating manual. Place the sediments into a sample container.



**SOP-S-03;
SEDIMENT SAMPLING FROM
STREAMS, PONDS, AND LAKES**

DATE ISSUED:
12/11/2014
REVISION: 0
PAGE 4 of 8

	<p>When collecting sediment samples in lakes, ponds, and streams, the site should be approximately at the center of the water mass. This is particularly true for reservoirs that are formed by the impoundment of rivers or streams. Generally, the coarser-grained sediments are deposited near the headwaters of the reservoirs, and the bed sediments near the center of the water mass will be composed of fine-grained materials. The shape, inflow pattern, bathymetry, and circulation must all be considered when selecting sediment sampling sites in lakes or reservoirs.</p> <p>In rivers or streams, fine-grained sediments are deposited on the outside of bends and downstream from islands or obstructions. Sample collection should follow those procedures outlined in the Collection of Shallow Depth Sediments section above.</p>
3. Sample collection using a boat or other sampling platform.	<p>When using a boat or other sampling platform, all engines should be turned off. The samples should be collected upstream from the engines or any other machinery that may release exhaust fumes/oils into the sample.</p>



SOP-S-03;
SEDIMENT SAMPLING FROM
STREAMS, PONDS, AND LAKES

DATE ISSUED:
 12/11/2014
REVISION: 0
 PAGE 5 of 8

HSSE CONSIDERATIONS
 This section to be completed with concurrence from the Safety and Health Manager.

<i>SOURCE</i>	<i>HAZARDS</i>	<i>WHERE</i>	<i>HOW, WHEN, RESULT</i>	<i>CONTROLS</i>
CHEMICAL	Potential contact with contaminated sediments and water.	Streams, ponds, and lakes.	Inadvertent exposure to contaminated sediments and water could lead to adverse health effects.	Personnel will practice proper personal hygiene – wash hands prior to eating/drinking and when leaving the site. Employees will wear nitrile gloves and safety glasses when collecting and handling samples.
NOISE	Not applicable.			
ELECTRICAL	Not applicable.			
BODY MECHANICS	Improper lifting. Bending, squatting, and kneeling. Drowning and/or entrapment hazards.	Testing sites. During sample collection. Streams, ponds, and lakes.	Back injuries and muscle/back strains could result when using improper techniques to lift and carry tools and equipment. Bending, squatting, and kneeling during sample collection could result in muscle/back strains or other injuries. Soft soils and/or sudden changes in depth of water could create drowning and/or entrapment hazards.	Personnel will use proper lifting techniques – get a good grip, keep the load close to the body, lift with legs and not with back, and avoid lifting loads above shoulder’s height. Two employees will lift objects, if necessary. Employees should stretch prior to starting work and they will take breaks when necessary. Workers will use rods to test soil stability and/or depth of water as they walk to sample locations. In addition, personnel may be required to wear life vests when crossing deeper bodies of water.
GRAVITY	Falls from slips and trips.	Uneven terrain, slick/muddy/wet surfaces and steep slopes.	Walking/working on slick/muddy/wet and uneven	Workers will wear work boots with good traction and ankle support. Personnel will be aware of working/walking



SOP-S-03;
SEDIMENT SAMPLING FROM
STREAMS, PONDS, AND LAKES

DATE ISSUED:
 12/11/2014
REVISION: 0
PAGE 6 of 8

			terrain could cause slips and trips resulting in falls and injuries.	surfaces and choose a path to avoid hazards. Keep work areas as dry as possible. Wear muck boots, as necessary.
WEATHER	Cold/heat stress.	Sites.	Exposure to cold climates may result in cold burns, frostbites, and hypothermia. Exposure to high temperatures may result in heat cramps, heat exhaustion, or heat stroke.	Training on signs and symptoms of cold/heat stress is required. Personnel will wear appropriate clothing when working outdoors. Employees will remain hydrated and will have sufficient caloric intakes during the day. Personnel will follow procedures outlined in applicable SSHASP and/or Pioneer corporate HASP.
	Hypothermia/frostbite.	Sites when air temperature is 35.6°F (2°C) or less.	Workers who become immersed in water or whose clothing becomes wet may be exposed to hypothermia and/or frostbite.	Employees will change clothing if it becomes wet. When applicable, employees will wear waders to prevent clothing from getting wet.
	Lightning.	Outdoor sites.	Electrocution, injury, death, or equipment damage could be caused by lightning strike.	Employees will follow the 30/30 rule during lightning storms.
RADIATION	Ultraviolet (UV) radiation.	Outdoors.	Employees could be exposed to UV radiation during summer months causing sun burns, skin damage, and eye damage.	Employees will wear safety glasses with tinted lenses, long-sleeve work shirts, and long pants. Employees should wear sunscreen, if necessary.
BIOLOGICAL	Plants, insects, and animals.	Sites	Exposure to plants, insects, and/or animals may cause rashes, blisters, redness,	Training on the signs and symptoms of exposure to plants, insects, and animals is required. Avoid contact with plants, insects, and animals.



SOP-S-03;
SEDIMENT SAMPLING FROM
STREAMS, PONDS, AND LAKES

DATE ISSUED:
 12/11/2014
REVISION: 0
PAGE 7 of 8

			and swelling.	First-aid kits will be available on site. Employees with allergies will notify their supervisor.
MECHANICAL	Not applicable.			
PRESSURE	Not applicable.			
THERMAL	Not applicable.			
HUMAN FACTORS	Inexperienced and improperly trained worker.	Sites.	Inexperienced workers and improper training could cause incidents resulting in adverse health effects and/or property damage.	Employees will be properly trained in this procedure and other applicable procedures. Employees will implement stop work procedures, if necessary.
SIMOPS	Not applicable.			

ADDITIONAL HSSE CONSIDERATIONS

This section to be completed with concurrence from the Safety and Health Manager.

REQUIRED PPE	Hard hat, safety glasses, high-visibility work shirt or vest, long pants, work boots, nitrile gloves, and leather gloves.
APPLICABLE SDS	Safety Data Sheets (SDSs) will be maintained based on site characterization and contaminants.
REQUIRED PERMITS/FORMS	Per site/project requirements.
ADDITIONAL TRAINING	Per site/project requirements.

DRAWINGS, DOCUMENTS, AND TOOLS/EQUIPMENT

The following documents should be referenced to assist in completing the associated task.

P&IDS	
DRAWINGS	Map with site location and sample locations.
RELATED SOPs/PROCEDURES/WORK PLANS	SOP-DE-02 Equipment Decontamination.
TOOLS	Sampling tools: disposable plastic scoop or clean stainless steel spoon or trowel; collection pan, stainless steel bowl and Ziploc bags; sample bottles; cooler.



**SOP-S-03;
SEDIMENT SAMPLING FROM
STREAMS, PONDS, AND LAKES**

DATE ISSUED:
12/11/2014
REVISION: 0
PAGE 8 of 8

	<p>For collection of sediment from deeper bodies of water: Teflon beaker or disposable plastic scoop attached to a telescoping pole; spring loaded sediment dredge or benthic sampler; rope.</p> <p>Field logbook or field data sheets and chain-of-custody forms.</p>
FORMS/CHECKLIST	

APPROVALS/CONCURRENCE	
<p>By signing this document, all parties acknowledge the completeness and applicability of this SOP for its intended purpose. Also, by signing this document, it serves as acknowledgement that I have received training on the procedure and associated competency testing.</p>	
SOP TECHNICAL AUTHOR	DATE
<p><i>Julie Flammang</i></p> <p>Julie Flammang</p>	12/11/2014
SAFETY AND HEALTH MANAGER	DATE
<p><i>Tara Schleeman</i></p> <p>Tara Schleeman</p>	12/11/2014

Revisions:

Revision	Description	Date

Appendix B.

Field Forms and Tables

FORMS



Project Name: _____
 Project Location: _____
 Project Number: _____

Log of Boring

Date(s) Drilled		Logged By		Total Depth of Borehole (ft)
Drilling Method		Diameter of Borehole (in)		Ground Surface Elevation (ft-msl)
Drill Rig Type		Drilling Company		Groundwater Elevation (ft-msl)
Driller's Name	Sampler Type	Checked By		Measuring Point Elevation (ft-msl)
Locations / Comments				Northing Easting

Depth (ft-bgs)	SAMPLES				Munsell Color	HCL Reaction	Drill Rate (ft/hr)	MATERIAL DESCRIPTION	REMARKS
	Sample Type	Blows/Foot	Recovery (ft)	Pentrometer (tsf)					
1									
2									
3									
4									
5									
6									
7									
8									
9									
10									
11									
12									
13									
14									
15									



Project Name: _____
Project Location: _____
Project Number: _____

Log of Boring

Depth (ft-bgs)	SAMPLES				Munsell Color	HCL Reaction	Drill Rate (ft/hr)	MATERIAL DESCRIPTION	REMARKS
	Sample Type	Blows/Foot	Recovery (ft)	Pentrometer (tsf)					
15									
16									
17									
18									
19									
20									
21									
22									
23									
24									
25									
26									
27									
28									
29									
30									
31									
32									
33									



Project Name: _____
 Project Location: _____
 Project Number: _____

Log of Boring

Depth (ft-bgs)	SAMPLES				Munsell Color	HCL Reaction	Drill Rate (ft/hr)	MATERIAL DESCRIPTION	REMARKS
	Sample Type	Blows/Foot	Recovery (ft)	Pentrometer (tsf)					
33									
34									
35									
36									
37									
38									
39									
40									
41									
42									
43									
44									
45									
46									
47									
48									
49									
50									
51									

TABLES

ORDER FOR DESCRIPTIONS

Density

- Very soft, Soft, Medium Stiff, Stiff, Stiff, Very Stiff, Hard
- Very loose, Loose, Medium Dense, Dense, Very Dense
- SEE TABLE

Moisture Content

- Dry, Moist, Wet
- See Table

General Color

Soil Description

- Minor soil type name with "y" added if ≥ 30 percent and $\leq 50\%$
- Descriptive adjective for main soil type
 - Particle-size distribution adjective for gravel and sand (fine – coarse)
 - Plasticity adjective (slight to high) and soil texture (silty or clayey) for inorganic and organic silts or clays
- Main soil type's name (**all capital letters**)
- Descriptive adjective such as trace (0-5%), slightly or some (5-12%), for minor soil type

Structures

- See Tables

Geologic Classification

- If applicable – alluvium, fill, tailings, slag, debris

USCS Classification

- See Tables

Examples:

Medium dense, wet, dark brown, sandy SILT, trace of clay, numerous organics and strong organic odor (marsh deposits) ML.

Medium stiff, moist, dark gray, medium plastic silty CLAY, slightly sandy, laminated with light gray silt (tailings), CL

Very dense, moist, light brown, slightly silty, sandy fine gravel, trace of cobbles, scattered roots, GP-GM

Density/Consistency Word Choices

Consistency of Fine-Grained Soils-Silts, Clays

Consistency	Results of Manual Manipulation
Very Soft	Specimen (height = twice the diameter) sags under its own weight; extrudes between fingers when squeezed
Soft	Specimen can be pinched in to between the thumb and forefinger; remolded by light finger pressure
Medium stiff	Can be imprinted easily with fingers; remolded by strong finger pressure
Stiff	Can be imprinted with considerable pressure from fingers or indented by thumbnail
Very stiff	Can be barely imprinted by pressure from the fingers or indented by thumbnail
Hard	Cannot be imprinted by fingers or difficult to indent by thumbnail

Density of Coarse or Cohesionless Soils-Gravels/Sands and Silt
Very loose
Loose
Medium Dense
Dense
Very Dense

WATER CONTENT

Description	Conditions
Dry	No sign of water and soil dry to touch
Moist	Signs of water and soil is relatively dry to touch
Wet	Signs of water and soil definitely wet to touch; granular soil exhibits some free water when densified, saturated

SIZES FOR SOIL DESCRIPTIONS

Term	Example	Size
Boulders	> Basketball size	> 12"
Cobbles	Fist to Basketball size	3"-12"
Gravel – Coarse	Thumb to fist size	¾"-3"
Gravel – Fine	Pea to Thumb size	5 mm to ¾"
Sand – Coarse	Rock salt to pea size	2 mm to 5 mm
Sand – Medium	Sugar to rock salt	0.4 mm to 2 mm
Sand – Fine	Flour to sugar	0.08 mm to 0.4 mm
Fines – Clay and silt	Grains are not visible	<0.08 mm

Boulders and cobbles are not considered soil or part of the soil's classification or description, except under miscellaneous descriptions; i.e. --, with cobbles at about 5 percent (volume).

Well graded coarse-grained soil - contains a good representation of all particle sizes from largest to smallest, with ≤ 12% **fines**.

Poorly graded coarse-grained soil is uniformly graded with most particles about the same size or lacking one or more intermediate sizes, with 12% fines.

Describe type and size of organic debris

Adjective	Presence as % by Volume
Occasional	0-1%
Scattered	1-10%
Numerous	10-30%
Organic – as a minor constituent in description	30-50%
PEAT – MAJOR constituent	50-100%

Highly Organic Materials

These materials containing a predominance of undecomposed plant or woody fiber are described as follows:

- *Root Mat*: Pronounced structure of living root fibers characteristic of marsh or swampy deposits.
- *Peat*: Fossiliferous root mat with a varying degree of decomposition, often containing a matrix of amorphous, colloidal organic clays and silts.
- *Humus*: Decomposed root and leaf litter, characteristic of organic forest cover in well-drained areas.

SOIL PLASTICITY DESCRIPTIONS

Plasticity Adjective	Dry Strength	Smear Test	Thread Smallest Diameter, in. (mm)	ML & MH (SILT)	CL & CH (CLAY)	OL & OH (ORGANIC SILT OR CLAY)
nonplastic	none-crumbles into powder with mere pressure	gritty or rough	ball cracks	----	----	ORGANIC SILT
low plasticity	low-crumbles into powder with some finger pressure	rough to smooth	1/4 to 1/8 (3 to 6)	----	silty	ORGANIC SILT
medium plastic	medium - breaks into pieces or crumbles with considerable finger pressure	smooth and dull	1/16 (0.5 to 1)	clayey	silty to no adj.	ORGANIC clayey SILT
highly plastic	high- cannot be broken with finger pressure; will break into pieces between thumb and a hard surface	shiny	1/32 (0.75)	clayey	----	ORGANIC silty CLAY
very plastic	very high - can't be broken between thumb and a hard surface	very shiny and waxy	1/64 (0.5)	clayey	----	ORGANIC

Thread Test:

Moisture is added or worked out of a small ball (about 1 1/2-inch diameter) and the ball is kneaded until its consistency approaches medium stiff to stiff and it breaks, or crumbles. A thread is then rolled out to the smallest diameter possible before disintegration. The smaller the thread achieved, the higher the plasticity of the soil. Fine-grained soils of high plasticity will have threads smaller than 1/32 inch in diameter. Soils with low plasticity will have threads larger than 1/8 inch in diameter.

Layered Soils

<u>Type of Layer</u>	<u>Thickness</u>	<u>Occurrence</u>
Parting	< 1/16 in.	
Lamination	< ¼ in.	
Seam	1/16 to ½ in.	
Layer	½ in. to 12 in.	
Stratum	> 12 in.	
Pocket	Small erratic deposit	
Lens	Lenticular deposit	
Varved (also layered)		Alternating seams or layers of silt and/or clay and sometimes f. sand
Occasional		One or less per foot of thickness or laboratory sample inspected
Frequent		More than one per foot of thickness or laboratory sample inspected

Place the thickness designation before the type of layer, or at the end of each description and in parentheses, whichever is more appropriate.

Examples of descriptions for layered soils are:

- Medium stiff, moist to wet 1/4"-3/4" interbedded seams and layers of: gray, medium plastic, silty CLAY (CL); and lt. gray, low plasticity SILT (ML); (Alluvium).

Other Layer Adjectives

Description	Criteria (thickness)
Stratified	Alternating Layers
Interbedded	Alternating Layers > ½" thick
Laminated	Alternating layers < ¼" thick
Fractured	Breaks easily along definite fractured planes
Slickensided	Polished, glossy, striated, fracture planes
Blocky	Easily breaks into small angular lumps
Lensed	Small pockets of different soils
Homogeneous	Same color and appearance throughout
Sheared	Disturbed texture, mix of strengths

Coarse- Grained Soils			
Coarse-Grained Soils	Gravel and Gravelly Soils	GW	Well-graded gravels or gravel- sand mixtures, little or no fines
		GP	Poorly graded gravels or gravel- sand mixtures, little or no fines
		GM	Silty gravels, gravel-sand-silt mixtures (more than 12% fines)
		GC	Clayey gravels, gravel-sand- clay mixtures (more than 12% fines)
	Sand and Sandy Soils	SW	Well-graded sands or gravelly sands, little or no fines
		SP	Poorly graded sands or gravelly sands, little or no fines
		SM	Silty sands, sand-silt mixtures (more than 12% fines)
		SC	Clayey sands, sand-silt mixtures (more than 12% fines)
FINE - GRAINED SOILS			
Fine-Grained Soils	Silts and Clays Liquid Limit < 50	ML	Inorganic silts and very fine sands, rock flour, silty or clayey fine sands or clayey silts with slight plasticity
		CL	Inorganic clays of low to medium plasticity, gravelly clays, sandy clays, silty clays, lean clays
		OL	<i>Organic</i> silts and organic silt- clays of low plasticity
	Silts and Clays Liquid Limits ≥ 50	MH	Inorganic silts, micaceous or diatomaceous fine sandy or silty soils, elastic silts
		CH	Inorganic clays of high plasticity, fat clays
		OH	<i>Organic</i> clays of medium to high plasticity, organic silts
		Pt	Peat and other highly organic soils
Highly <i>Organic</i> Soils			

Well Graded - all particle sizes are present, less than 12% fines

Poorly Graded - most particles are about the same size or missing 1 or 2 sizes, 12% fines



TITLE:	GEOLOGIC LOGGING		
CATEGORY:	GEO 4.8		March 1998

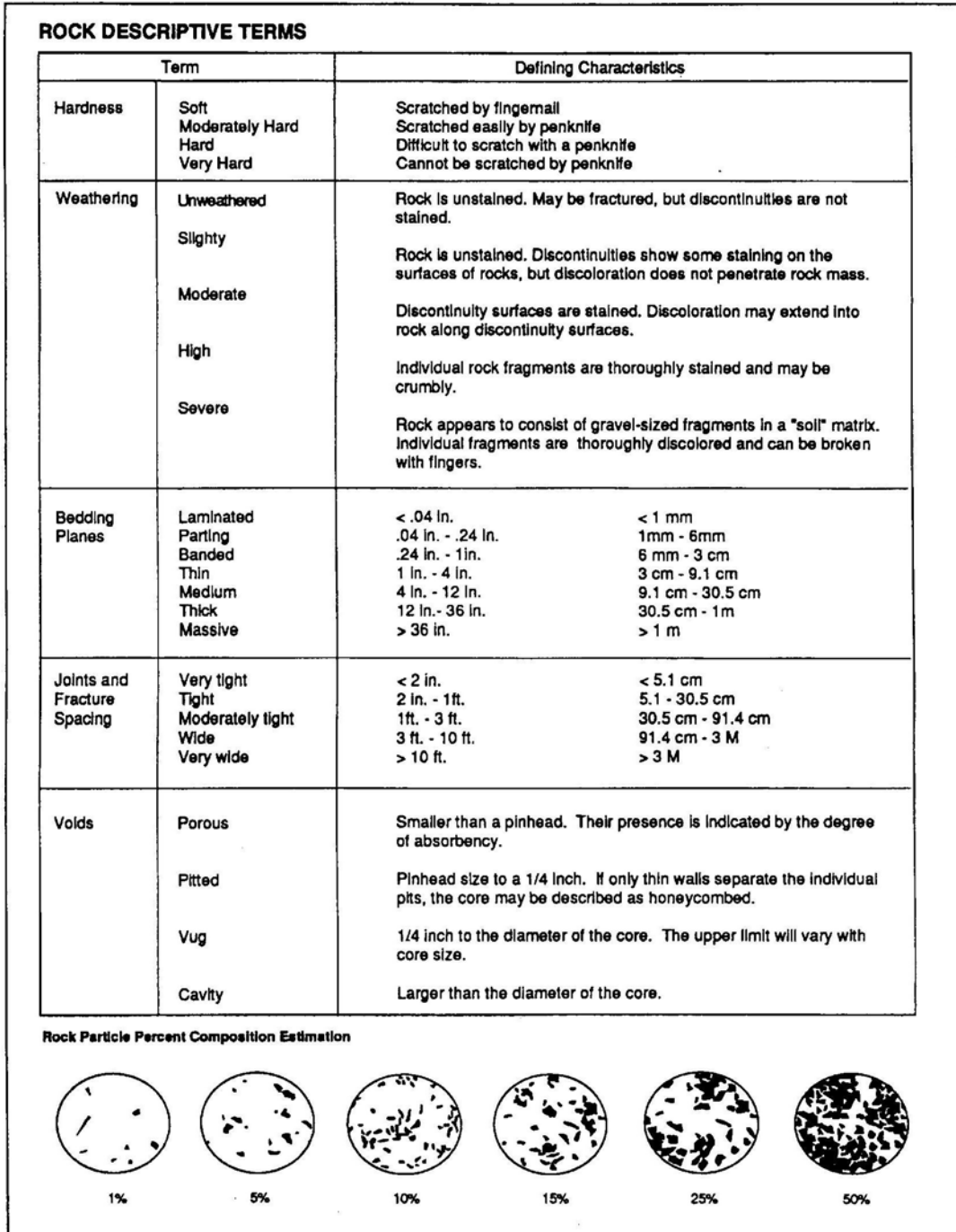

Figure 3 Rock Descriptive Terms

Appendix C.
Geotechnical Investigation Reference Documents



Designation: D1587/D1587M – 15

Standard Practice for Thin-Walled Tube Sampling of Fine-Grained Soils for Geotechnical Purposes¹

This standard is issued under the fixed designation D1587/D1587M; the number immediately following the designation indicates the year of original adoption or, in the case of revision, the year of last revision. A number in parentheses indicates the year of last reapproval. A superscript epsilon (ϵ) indicates an editorial change since the last revision or reapproval.

This standard has been approved for use by agencies of the U.S. Department of Defense.

1. Scope

1.1 This practice covers a procedure for using a thin-walled metal tube to recover intact soil samples suitable for laboratory tests of engineering properties, such as strength, compressibility, permeability, and density. This practice provides guidance on proper sampling equipment, procedures, and sample quality evaluation that are used to obtain intact samples suitable for laboratory testing.

1.2 This practice is limited to fine-grained soils that can be penetrated by the thin-walled tube. This sampling method is not recommended for sampling soils containing coarse sand, gravel, or larger size soil particles, cemented, or very hard soils. Other soil samplers may be used for sampling these soil types. Such samplers include driven split barrel samplers and soil coring devices (Test Methods [D1586](#), [D3550](#), and Practice [D6151](#)). For information on appropriate use of other soil samplers refer to Practice [D6169](#).

1.3 This practice is often used in conjunction with rotary drilling (Practice [D1452](#) and Guides [D5783](#) and [D6286](#)) or hollow-stem augers (Practice [D6151](#)). Subsurface geotechnical explorations should be reported in accordance with Practice [D5434](#). This practice discusses some aspects of sample preservation after the sampling event. For more information on preservation and transportation process of soil samples, consult Practice [D4220](#).

1.4 This practice may not address special considerations for environmental or marine sampling; consult Practices [D6169](#) and [D3213](#) for information on sampling for environmental and marine explorations.

1.5 Thin-walled tubes meeting requirements of [6.3](#) can also be used in piston samplers, or inner liners of double tube push or rotary-type soil core samplers (Pitcher barrel, Practice [D6169](#)). Piston samplers in Practice [D6519](#) use thin-walled tubes.

1.6 All observed and calculated values shall conform to the guidelines for significant digits and rounding established in Practice [D6026](#), unless superseded by this standard.

1.7 This practice offers a set of instructions for performing one or more specific operations. This document cannot replace education or experience and should be used in conjunction with professional judgment. Not all aspects of this practice may be applicable in all circumstances. This ASTM standard is not intended to represent or replace the standard of care by which the adequacy of a given professional service must be judged, nor should this document be applied without consideration of a project's many unique aspects. The word "Standard" in the title of this document means only that the document has been approved through the ASTM consensus process.

1.8 The values stated in either inch-pound units or SI units presented in brackets are to be regarded separately as standard. The values stated in each system may not be exact equivalents; therefore, each system shall be used independently of the other. Combining values from the two systems may result in non-conformance with the standard.

1.9 *This standard does not purport to address all of the safety concerns, if any, associated with its use. It is the responsibility of the user of this standard to establish appropriate safety and health practices and determine the applicability of regulatory limitations prior to use.*

2. Referenced Documents

2.1 ASTM Standards:²

- [A513/A513M](#) Specification for Electric-Resistance-Welded Carbon and Alloy Steel Mechanical Tubing
- [A519](#) Specification for Seamless Carbon and Alloy Steel Mechanical Tubing
- [A787](#) Specification for Electric-Resistance-Welded Metallic-Coated Carbon Steel Mechanical Tubing
- [B733](#) Specification for Autocatalytic (Electroless) Nickel-Phosphorus Coatings on Metal

¹ This practice is under the jurisdiction of ASTM Committee [D18](#) on Soil and Rock and is the direct responsibility of Subcommittee [D18.02](#) on Sampling and Related Field Testing for Soil Evaluations.

Current edition approved Nov. 15, 2015. Published December 2015. Originally approved in 1958. Last previous edition approved in 2012 as D1587 – 08 (2012)¹. DOI: 10.1520/D1587_D1587M-15.

² For referenced ASTM standards, visit the ASTM website, www.astm.org, or contact ASTM Customer Service at service@astm.org. For *Annual Book of ASTM Standards* volume information, refer to the standard's Document Summary page on the ASTM website.

*A Summary of Changes section appears at the end of this standard

- D653 Terminology Relating to Soil, Rock, and Contained Fluids
- D1452 Practice for Soil Exploration and Sampling by Auger Borings
- D1586 Test Method for Penetration Test (SPT) and Split-Barrel Sampling of Soils
- D2166 Test Method for Unconfined Compressive Strength of Cohesive Soil
- D2435 Test Methods for One-Dimensional Consolidation Properties of Soils Using Incremental Loading
- D2488 Practice for Description and Identification of Soils (Visual-Manual Procedure)
- D2850 Test Method for Unconsolidated-Undrained Triaxial Compression Test on Cohesive Soils
- D3213 Practices for Handling, Storing, and Preparing Soft Intact Marine Soil
- D3550 Practice for Thick Wall, Ring-Lined, Split Barrel, Drive Sampling of Soils (Withdrawn 2016)³
- D3740 Practice for Minimum Requirements for Agencies Engaged in Testing and/or Inspection of Soil and Rock as Used in Engineering Design and Construction
- D4186 Test Method for One-Dimensional Consolidation Properties of Saturated Cohesive Soils Using Controlled-Strain Loading
- D4220 Practices for Preserving and Transporting Soil Samples
- D4452 Practice for X-Ray Radiography of Soil Samples
- D4767 Test Method for Consolidated Undrained Triaxial Compression Test for Cohesive Soils
- D5434 Guide for Field Logging of Subsurface Explorations of Soil and Rock
- D5783 Guide for Use of Direct Rotary Drilling with Water-Based Drilling Fluid for Geoenvironmental Exploration and the Installation of Subsurface Water-Quality Monitoring Devices
- D6026 Practice for Using Significant Digits in Geotechnical Data
- D6151 Practice for Using Hollow-Stem Augers for Geotechnical Exploration and Soil Sampling

- D6169 Guide for Selection of Soil and Rock Sampling Devices Used With Drill Rigs for Environmental Investigations
- D6282 Guide for Direct Push Soil Sampling for Environmental Site Characterizations
- D6286 Guide for Selection of Drilling Methods for Environmental Site Characterization
- D6519 Practice for Sampling of Soil Using the Hydraulically Operated Stationary Piston Sampler

3. Terminology

3.1 *Definitions:*

3.1.1 For common definitions of terms in this standard, refer to Terminology D653.

3.2 *Definitions of Terms Specific to This Standard:*

3.2.1 *area ratio, A_r, %, n*—the ratio of the soil displaced by the sampler tube in proportion to the area of the sample expressed as a percentage (see Fig. 1).

3.2.2 *inside clearance ratio, C_r, %, n*—the ratio of the difference in the inside diameter of the tube, D_i, minus the inside diameter of the cutting edge, D_e, to the inside diameter of the tube, D_i expressed as a percentage (see Fig. 1).

3.2.3 *ovality, n*—the cross section of the tube that deviates from a perfect circle.

3.3 *Symbols:*

3.3.1 A_r—area ratio (see 3.2.1).

3.3.2 C_r—clearance ratio (see 3.2.2).

4. Summary of Practice

4.1 A relatively intact sample is obtained by pressing a thin-walled metal tube into the in-situ soil at the bottom of a boring, removing the soil-filled tube, and applying seals to the soil surfaces to prevent soil movement and moisture gain or loss.

5. Significance and Use

5.1 Thin-walled tube samples are used for obtaining intact specimens of fine-grained soils for laboratory tests to determine engineering properties of soils (strength, compressibility, permeability, and density). Fig. 2 shows the use of the sampler

³ The last approved version of this historical standard is referenced on www.astm.org.

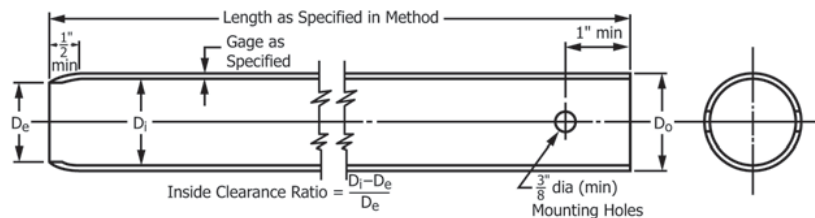

$$\text{Area Ratio} = (D_o^2 - D_i^2) / D_i^2$$

NOTE 1—The sampling end of the tube is manufactured by rolling the end of the tube inward and then machine cutting the sampling diameter, D_e, on the inside of the rolled end of the tube.

NOTE 2—Minimum of two mounting holes on opposite sides for D_o smaller than 4 in. [100 mm]. Minimum of four mounting holes equally spaced for D_o equal to 4 in. [100 mm] and larger.

NOTE 3—Tube held with hardened set screws or other suitable means.

FIG. 1 Thin-Walled Dimensions for Measuring Tube Clearance Ratio, C_r (approximate metric equivalents not shown)

TABLE 1 Suitable Thin-Walled Steel Sample Tubes^A

Outside diameter (D _o):	2	3	5
in.			
mm	50	75	125
Wall thickness:			
Bwg	18	16	11
in.	0.049	0.065	0.120
mm	1.25	1.65	3.05
Tube length:			
in.	36	36	54
m	1.0	1.0	1.5

^A The three diameters recommended in Table 2 are indicated for purposes of standardization, and are not intended to indicate that sampling tubes of intermediate or larger diameters are not acceptable. Lengths of tubes shown are illustrative. Proper lengths to be determined as suited to field conditions. Wall thickness may be changed (5.2.1, 6.3.2). Bwg is Birmingham Wire Gauge (Specification A513/A513M).

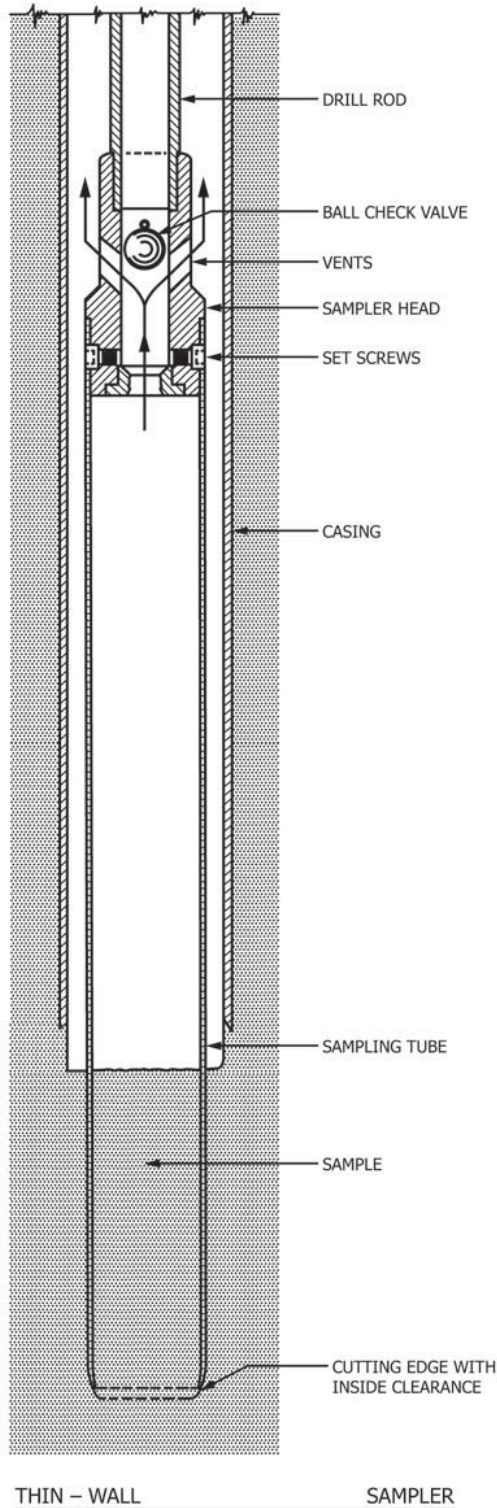

FIG. 2 Thin-Walled Tube Sampler Schematic and Operation (1)

in a drill hole. Typical sizes of thin-walled tubes are shown on Table 1. The most commonly used tube is the 3-in. [75 mm] diameter. This tube can provide intact samples for most laboratory tests; however some tests may require larger diam-

eter tubes. Tubes with a diameter of 2 in. [50 mm] are rarely used as they often do not provide specimens of sufficient size for most laboratory testing.

5.1.1 Soil samples must undergo some degree of disturbance because the process of subsurface soil sampling subjects the soil to irreversible changes in stresses during sampling, extrusion if performed, and upon removal of confining stresses. However, if this practice is used properly, soil samples suitable for laboratory testing can be procured. Soil samples inside the tubes can be readily evaluated for disturbance or other features such as presence of fissures, inclusions, layering or voids using X-ray radiography (D4452) if facilities are available. Field extrusion and inspection of the soil core can also help evaluate sample quality.

5.1.2 Experience and research has shown that larger diameter samples (5 in. [125 mm]) result in reduced disturbance and provide larger soil cores available for testing. Agencies such as the U.S Army Corps of Engineers and US Bureau of Reclamation use 5-in. [125-mm] diameter samplers on large exploration projects to acquire high quality samples (1, 2, 3).⁴

5.1.3 The lengths of the thin-walled tubes (tubes) typically range from 2 to 5 ft [0.5 to 1.5 m], but most are about 3 ft [1 m]. While the sample and push lengths are shorter than the tube, see 7.4.1.

5.1.4 This type of sampler is often referred to as a “Shelby Tube.”

5.2 Thin-walled tubes used are of variable wall thickness (gauge), which determines the Area Ratio (A_r). The outside cutting edge of the end of the tube is machined-sharpened to a cutting angle (Fig. 1). The tubes are also usually supplied with a machine-beveled inside cutting edge which provides the Clearance Ratio (C_r). The recommended combinations of A_r, cutting angle, and C_r are given below (also see 6.3 and Appendix X1, which provides guidance on sample disturbance).

5.2.1 A_r should generally be less than 10 to 15 %. Larger A_r of up to 25 to 30 % have been used for stiffer soils to prevent buckling of the tube. Tubes of thicker gauge may be requested when re-use is anticipated (see 6.3.2).

⁴ The boldface numbers in parentheses refer to a list of references at the end of this standard.

5.2.2 The cutting edge angle should range from 5 to 15 degrees. Softer formations may require sharper cutting angles of 5 to 10 degrees, however, sharp angles may be easily damaged in deeper borings. Cutting edge angles of up to 20 to 30 degrees have been used in stiffer formations in order to avoid damage to the cutting edges.

5.2.3 Optimum C_r depends on the soils to be tested. Soft clays require C_r of 0 or less than 0.5 %, while stiffer formations require larger C_r of 1 to 1.5 %.

5.2.3.1 Typically, manufacturers supply thin-walled tubes with C_r of about 0.5 to 1.0 % unless otherwise specified. For softer or harder soils C_r tubes may require special order from the supplier.

5.3 The most frequent use of thin-walled tube samples is the determination of the shear strength and compressibility of soft to medium consistency fine-grained soils for engineering purposes from laboratory testing. For determination of undrained strength, unconfined compression or unconsolidated, undrained triaxial compression tests are often used (Test Methods [D2166](#) and [D2850](#)). Unconfined compression tests should be only used with caution or based on experience because they often provide unreliable measure of undrained strength, especially in fissured clays. Unconsolidated undrained tests are more reliable but can still suffer from disturbance problems. Advanced tests, such as consolidated, undrained triaxial compression (Test Method [D4767](#)) testing, coupled with one dimensional consolidation tests (Test Methods [D2435](#) and [D4186](#)) are performed for better understanding the relationship between stress history and the strength and compression characteristics of the soil as described by Ladd and Degroot, 2004 ([4](#)).

5.3.1 Another frequent use of the sample is to determine consolidation/compression behavior of soft, fine-grained soils using One-Dimensional Consolidation Test Methods [D2435](#) or [D4186](#) for settlement evaluation. Consolidation test specimens are generally larger diameter than those for strength testing and larger diameter soil cores may be required. Disturbance will result in errors in accurate determination of both yield stress ([5.3](#)) and stress history in the soil. Disturbance and sample quality can be evaluated by looking at recompression strains in the One-Dimensional Consolidation test (see Andressen and Kolstad ([5](#))).

5.4 Many other sampling systems use thin-walled tubes. The piston sampler (Practice [D6519](#)) uses a thin-walled tube. However, the piston samplers are designed to recover soft soils and low-plasticity soils and the thin-walled tubes used must be of lower C_r of 0.0 to 0.5 %. Other piston samplers, such as the Japanese and Norwegian samplers, use thin-walled tubes with 0 % C_r (see [Appendix X1](#)).

5.4.1 Some rotary soil core barrels (Practice [D6169](#)-Pitcher Barrel), used for stiff to hard clays use thin-walled tubes. These samplers use high C_r tubes of 1.0 to 1.5 % because of core expansion and friction.

5.4.2 This standard may not address other composite double-tube samplers with inner liners. The double-tube samplers are thicker walled and require special considerations for an outside cutting shoe and not the inner thin-walled liner tube.

5.4.3 There are some variations to the design of the thin-walled sampler shown on [Fig. 2](#). Figure 2 shows the standard sampler with a ball check valve in the head, which is used in fluid rotary drilled holes. One variation is a Bishop-type thin-walled sampler that is capable of holding a vacuum on the sampler to improve recovery ([1](#), [2](#)). This design was used to recover sand samples that tend to run out of the tube with sampler withdraw.

5.5 The thin-walled tube sampler can be used to sample soft to medium stiff clays⁵. Very stiff clays⁵ generally require use of rotary soil core barrels (Practice [D6151](#), Guide [D6169](#)). Mixed soils with sands can be sampled but the presence of coarse sands and gravels may cause soil core disturbance and tube damage. Low-plasticity silts can be sampled but in some cases below the water table they may not be held in the tube and a piston sampler may be required to recover these soils. Sands are much more difficult to penetrate and may require use of smaller diameter tubes. Gravelly soils cannot be sampled and gravel will damage the thin-walled tubes.

5.5.1 Research by the US Army Corps of Engineers has shown that it is not possible to sample clean sands without disturbance ([2](#)). The research shows that loose sands are densified and dense sands are loosened during tube insertion because the penetration process is drained, allowing grain rearrangement.

5.5.2 The tube should be pushed smoothly into the cohesive soil to minimize disturbance. Use in very stiff and hard clays with insertion by driving or hammering cannot provide an intact sample. Samples that must be obtained by driving should be labeled as such to avoid any advanced laboratory testing for engineering properties.

5.6 Thin-walled tube samplers are used in mechanically drilled boreholes (Guide [D6286](#)). Any drilling method that ensures the base of the borehole is intact and that the borehole walls are stable may be used. They are most often used in fluid rotary drill holes (Guide [D5783](#)) and holes using hollow-stem augers (Practice [D6151](#)).

5.6.1 The base of the boring must be stable and intact. The sample depth of the sampler should coincide with the drilled depth. The absence of slough, cuttings, or remolded soil in the top of the samples should be confirmed to ensure stable conditions ([7.4.1](#)).

5.6.2 The use of the open thin-walled tube sampler requires the borehole be cased or the borehole walls must be stable as soil can enter the open sampler tube from the borehole wall as it is lowered to the sampling depth. If samples are taken in uncased boreholes the cores should be inspected for any sidewall contamination.

5.6.3 Do not use thin-walled tubes in uncased fluid rotary drill holes below the water table. A piston sampler (Practice [D6519](#)) must be used to ensure that there is no fluid or sidewall contamination that would enter an open sampling tube.

5.6.4 Thin-walled tube samples can be obtained through Dual Tube Direct Push casings (Guide [D6282](#)).

⁵ Soil Mechanics in Engineering Practice, Terzaghi, K. and R.B Peck, (1967) Second Edition, John Wiley & Sons, New York, Table 45.2, pg. 347.

5.6.5 Thin-walled tube samples are sometimes taken from the surface using other hydraulic equipment to push in the sampler. The push equipment should provide a smooth continuous vertical push.

5.7 Soil cores should not be stored in steel tubes for more than one to two weeks, unless they are stainless steel or protected by corrosion resistant coating or plating (6.3.2), see **Note 1**. This is because once the core is in contact with the steel tube, there are galvanic reactions between the tube and the soil which generally cause the annulus core to harden with time. There are also possible microbial reactions caused by temporary exposure to air. It is common practice to extrude or remove the soil core either in the field or at the receiving laboratory immediately upon receipt. If tubes are for re-use, soil cores must be extruded quickly within a few days since damage to any inside coatings is inevitable in multiple re-use. Extruded cores can be preserved by encasing the cores in plastic wrap, tin foil, and then microcrystalline wax to preserve moisture.

5.7.1 Soil cores of soft clays may be damaged in the extrusion process. In cases where the soil is very weak, it may be required to cut sections of the tube to remove soil cores for laboratory testing. See **Appendix X1** for recommended techniques.

NOTE 1—The one to two week period is just guideline typically used in practice. Longer time periods may be allowed depending on logistics and the quality assurance requirements of the exploration plan.

NOTE 2—The quality of the result produced by this standard is dependent on the competence of the personnel performing it, and the suitability of the equipment and facilities used. Agencies that meet the criteria of Practice **D3740** are generally considered capable of competent and objective sampling. Users of this practice are cautioned that compliance with Practice **D3740** does not in itself ensure reliable results. Reliable results depend on many factors; Practice **D3740** provides a means of evaluating some of those factors.

6. Apparatus

6.1 *Drilling Equipment*—When sampling in a boring, any drilling equipment may be used that provides a reasonably clean hole; that minimizes disturbance of the soil to be sampled; and that does not hinder the penetration of the thin-walled sampler (Guide **D6286**). Open borehole diameter and the inside diameter of driven casing or hollow stem auger shall not exceed 3.5 times the outside diameter of the thin-walled tube.

6.2 *Sampler Insertion Equipment*, shall be adequate to provide a relatively rapid continuous penetration force.

6.3 *Thin-Walled Tubes*—The tubes are either steel or stainless steel although other metals may be used if they can meet the general tolerances given in **Table 2** and have adequate strength for the soil to be sampled. Electrical Resistance Steel welded tubing meeting requirements of Specification **A513/A513M** are commonly used but it must meet the strict the SSID (Special Smooth Inside Diameter) and DOM (Drawn Over Mandrel) tolerances. **Table 2** is taken from older versions of this standard, and is in general agreement with Specification **A513/A513M** with tubes meeting SSID and DOM requirements. Seamless steel tubing (Specification **A519**) meeting requirements of **Table 2** may avoid problems associated with

TABLE 2 Dimensional Tolerances for Thin-Walled Tubes

Size Outside Diameter	Nominal Tube Diameters from Table 1 ⁴ Tolerances					
	2 in.	[50 mm]	3 in.	[75 mm]	5 in.	[125 mm]
Outside diameter, D_o	+0.007 -0.000	+0.179 -0.000	+0.010 -0.000	+0.254 -0.000	+0.015 -0.000	0.381 -0.000
Inside diameter, D_i	+0.000 -0.007	+0.000 -0.179	+0.000 -0.010	+0.000 -0.254	+0.000 -0.015	+0.000 -0.381
Wall thickness	±0.007	±0.179	±0.010	±0.254	±0.015	±0.381
Ovality	0.015	0.381	0.020	0.508	0.030	0.762
Straightness	0.030/ft	2.50/m	0.030/ft	2.50/m	0.030/ft	2.50/m

⁴Intermediate or larger diameters should be proportional. Specify only two of the first three tolerances; that is, D_o and D_i , or D_o and Wall thickness, or D_i and Wall thickness.

welded tube, such as improper or poor quality welds, and will have better roundness (ovality). Tubes shall be clean and free of all surface irregularities including projecting weld seams. Other diameters may be used but the tube dimensions should be proportional to the tube designs presented here. Tubes may be supplied with a light coating of oil to prevent rusting in storage. Measure the inside and outside diameters, and diameter of the cutting edge to check for ovality and C_r (6.3.2) with micrometers to ascertain that tubes meet these general tolerance requirements.

6.3.1 *Length of Tubes*—See **Table 1**, 7.5.1 and **Appendix X1**. Use tubes at least 3 in. [75 mm] longer than the design push length to accommodate slough/cuttings.

6.3.2 *Wall Thickness of Tubes*—**Table 1** shows typical wall thickness for the different diameter tubes. For heavy duty or anticipated re-use, the wall thickness can be increased. For example, a 3 in. [75 mm] tube may be increased from Bwg 16 (0.065 in.) to Bwg 14 (0.083 in.). If tubes are to be re-used, they must be thoroughly cleaned and inspected prior to each re-use. Do not re-use tubes that are bent or out of round, or have damaged cutting edges, inside corrosion or corrosion coating damage. Repair re-used tube damage to the cutting edges that would disturb or obstruct passage of the core using a file to maintain a sharp cutting edge.

6.3.3 *Inside Clearance Ratio (C_r)*—Sample tubes are manufactured with the inward rolled end and machine cut inside diameter, D_e , to clearance ratios ranging from 0.5 to 1.0 % (**Fig. 1**). Special order tubes of less than 0.5%. Select the proper C_r for the soil to be tested when ordering tubes based on site conditions. Clearance ratio ranges from 0 % for very soft clays to 1.5 % for stiff soils as discussed in 5.2 and **Appendix X1**. In the field, if there is evidence of soil disturbance such as loose soil within the tube, samples falling out, compressed or expanded sample lengths, etc., change the C_r or push length.

6.3.3.1 A recommended tube for very soft clays with 0% C_r for 3-in. [75-mm] sample tubes is shown on **Fig. 3** showing the recommended cutting angle. These special order tubes do not require the end rolling process.

6.3.4 *Corrosion Protection*—Subsection 5.7 recommends prompt extrusion of soil cores with no corrosion resistant coating. Corrosion, whether from galvanic or chemical reaction, can damage both the thin-walled tube and the soil sample. Severity of damage is a function of time as well as interaction between the sample and the tube. Thin-walled tubes should have some form of protective coating, unless the soil is

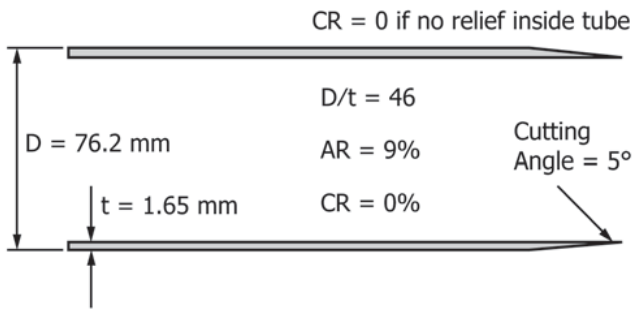

FIG. 3 Schematic of Standard 3-in. [75-mm] Thin-Walled Tube Modified by Removing the Beveled Cutting Edge and Machining a Five-Degree Cutting Angle (DeGroot and Landon (6)).

to be extruded in less than seven days. Organic or inorganic lubricants like penetrating oil and non-stick cooking spray have been used to lubricate the tube prior to sampling and also aid in extrusion and reduce friction. Tubes have been coated with lacquer or epoxy for reuse, but lacquer may not be suitable for longer storage periods and must be inspected for inside wear.

6.3.4.1 *Corrosion Resistant Tubing and Coatings*—Stainless steel and brass tubes are resistant to corrosion. Other types of coatings to be used may vary depending upon the material to be sampled. Plating of the tubes or alternate base metals may be specified. In general the coating should be of sufficient hardness and thickness to resist scratching that can occur from quartz sand particles, Nickel Electroless plating (Specification B733) has been used with good results. Galvanized tubes are often used when long term storage is required.

6.4 *Sampler Head*, serves to couple the thin-walled tube to the insertion equipment and, together with the thin-walled tube, comprises the thin-walled tube sampler. The sampler head shall contain a venting area and suitable ball check valve with the venting area to the outside equal to or greater than the area through the ball check valve. In some special cases, a ball check valve may not be required but venting is required to avoid sample compression. Fluid ports shall be designed to pass drill fluid or water through with minimal back pressure for push rates up to 1 ft [0.3 m] per second (fast push rate, 7.5).

7. Procedure

7.1 Remove loose material from the center of a casing or hollow stem auger as carefully as possible to avoid disturbance of the material to be sampled. If groundwater is encountered, maintain the liquid level in the borehole at or above groundwater level during the drilling and sampling operation.

7.2 Bottom discharge bits are not permitted. Side discharge bits may be used, with caution. Jetting through an open-tube sampler to clean out the borehole to sampling elevation is not permitted.

NOTE 3—Roller bits are available in downward-jetting and diffused-jet configurations. Downward-jetting configuration rock bits are not acceptable. Diffuse-jet configurations are generally acceptable.

7.3 Prepare and inspect the sampling tube and secure to the sampling head and drill rods. If desired or required, lubricate the inside of the tube just prior to sampling (see 6.3.4). Attachment of the head to the tube shall be concentric and

coaxial to ensure uniform application of force to the tube by the sampler insertion equipment.

7.4 Lower the sampling apparatus so that the sample tube's bottom rests on the bottom of the hole and record depth to the bottom of the sample tube to the nearest 0.1 ft [0.03 m].

7.4.1 The depth at which the tube rests should agree with the previous depth of cleanout using the drill bit to within 0.2 to 0.4 ft [50 to 100 mm], indicating a stable borehole. If the depth is less than the cleanout depth there could be excessive cuttings, slough/cave, or heave of the borehole and the borehole must be re-drilled, re-cleaned and stabilized for sampling. If the depth is deeper than the cleanout depth this may be normal because the thin-walled tube will penetrate partially under the weight of the rods. If the sampler penetrates significantly while resting at the base of the boring, adjust (shorten) the push length.

NOTE 4—Using a piston sampler (D6519) may alleviate many of the problems listed above. It is useful if there is excessive slough collected in the open thin wall tubes in unstable boreholes. With the piston locked in place, the sampler can generally be pressed through slough or cuttings to the cleanout depth without sample contamination with disturbed soil.

7.4.1.1 Keep the sampling apparatus plumb during lowering, thereby preventing the cutting edge of the tube from scraping the wall of the borehole.

7.5 Advance the sampler without rotation by a continuous relatively rapid downward push using the drill head and record length of advancement to the nearest 1 in. [25 mm] or better. The push should be smooth and continuous. It should take less than 15 seconds to push a typical 3-ft [1-m] sample tube. Note any difficulties in accomplishing the required push length.

7.5.1 Determine the length of advance by the resistance and condition of the soil formation. In no case shall a length of advance be greater than the sample-tube length minus an allowance for the sampler head and a minimum of 3 in. [75 mm] for sludge and end cuttings.

7.5.2 If the drill equipment is equipped with a pressure gauge that reads the reaction to pushing at a smooth rate, this pressure can be recorded and noted during the sampling process. The noting of the difficulty or ease of pushing could be valuable to select samples for lab testing. Low pressure pushes may indicate softer or weaker soils.

NOTE 5—The mass of sample, laboratory handling capabilities, transportation problems, and commercial availability of tubes will generally limit maximum practical lengths to those shown in Table 1.

7.5.3 When the soil formation is too hard for push-type insertion, use rotary soil core barrels for stiff to hard deposits for obtaining intact samples. If a tube must be driven then record the driving method and label the tube "driven sample."

7.6 Withdraw the sampler from the soil formation as carefully as possible in order to minimize disturbance of the sample. There is no set requirement for removing the tube. The process used should avoid the loss of core and recover a full sample. Typical practice uses a waiting period of 5 to 15 minutes after sampling before withdraw. This is to both dissipate excess pore pressures from the push and to build some adherence/adhesion of the soil core inside the tube. Where the soil formation is soft, a delay before withdraw of the

sampler may improve sample recovery. After the waiting period, typical practice is to rotate the sampler one revolution while in-place to shear off the bottom of the sample and relieve water or suction pressure prior to retraction. The waiting period and the shearing process may not be practical in some cases, such as deep marine sampling, and the sample can be removed without these steps as long as sample recovery is good.

7.6.1 Sometimes lower plasticity soils will fall out of the tube when the tube clears the water level inside the casing. If this occurs use a piston sampler (D6519) and/or reduce the C_r of the thin-walled tube. A lesser desired alternative is to maintain the borehole fluid level as the sample is retracted, and use a steel sheet plate or plywood to try to catch the soil core when the tube clears the fluid.

7.7 *Tube Re-Use*—If tubes are to be re-used, the soil cores must be extracted promptly and the tubes should be thoroughly cleaned using a high pressure washer or hand held cleaner that can reach fully inside the tube. Inspect the tubes for damage and discard any damaged tubes and repair the cutting edge if damaged (6.3.2).

8. Sample Measurement, Sealing and Labeling

8.1 Upon removal of the tube, remove the drill cuttings in the upper end of the tube using an insides diameter cutting tool and measure the length of the soil sample recovered to the nearest 1 in. [25 mm] or better in the tube. Recovery may be recorded, but may not be reliable due to uncertainty in removal of the upper slough, but it is important to note core loss and slippage. Seal the upper end of the tube. Remove at least 1 in. [25 mm] of material from the lower end of the tube. Use this material for soil description in accordance with Practice D2488. Measure the overall sample length to the nearest 1 in. [25 mm] or better. Seal the lower end of the tube. Alternatively, after measurement, the tube may be sealed without removal of soil from the ends of the tube.

NOTE 6—If the tubes are mass tared and their inside diameters are known, the mass of tube and soil can be determined and using the diameter and length for volume, the wet density of the soil core can be calculated. Further, the dry density can be determined using water content from the bottom trimmings. This extra information can be valuable in assisting lab selection of tubes for testing. The procedure is outlined in the Earth Manual (3).

8.1.1 *Sealing Tubes*—Seal and confine the soil in the tubes using either expandable packers or waxed wood discs inside the tube. Tubes sealed over the ends are generally poor quality, as opposed to those sealed with expanding packers, and should be provided with spacers or appropriate packing materials, or both prior to sealing the tube ends to provide proper confinement. Packing materials must be nonabsorbent and must maintain their properties to provide the same degree of sample support with time.

8.1.2 Samples of soft or very soft clays may require tube cutting in the laboratory for removal as opposed to extrusion (Appendix X1).

8.1.3 *Extruded Cores*—Depending on the requirements of the exploration, field extrusion and packaging of extruded soil samples can be performed. This allows for physical examination, photographing, and classification of the sample.

Samples are extruded in special device equipped which includes hydraulic jacks with properly sized platens to extrude the core in a smooth continuous speed. In some cases, further extrusion may cause sample disturbance reducing suitability for testing of engineering properties. In other cases, if damage is not significant, cores can be extruded and preserved for testing (Practice D4220). Bent or damaged tubes should be cut off before extruding. Preservation of intact sections of core is normally accomplished with a layer of plastic wrap and several layers of tin foil and wax to support the soil core. The extruded cores can be placed in PVC half rounds to aid in stability. Do not seal damaged portions of the extruded cores, generally the end sections, if they are not suitable for testing.

8.2 Prepare and immediately affix labels or apply markings as necessary to identify the sample (see Section 9). Ensure that the markings or labels are adequate to survive transportation and storage.

9. Report: Field Data Sheet(s)/Log(s)

9.1 The methodology used to specify how data are recorded on the test data sheet(s)/log(s), as given below, is covered in 1.6.

9.2 Record the following general information that may be required for preparing field logs in general accordance with Guide D5434. This guide is used for logging explorations by drilling and sampling. Some examples of the information required include;

- 9.2.1 Name and location of the project,
- 9.2.2 Boring number,
- 9.2.3 Log of the soil conditions,
- 9.2.4 Location of the boring,
- 9.2.5 Method of making the borehole,
- 9.2.6 Name of the drilling foreman and company,
- 9.2.7 Name of the drilling inspector(s),
- 9.2.8 Date and time of boring-start and finish,
- 9.2.9 Description of thin-walled tube sampler: size, type of metal, type of coating,
- 9.2.10 Method of sampler insertion: push or drive, and any difficulties in accomplishing the required push length,
- 9.2.11 Push pressures if recorded,
- 9.2.12 Label any driven samples (7.5.3),
- 9.2.13 Method of drilling, size of hole, casing, and drilling fluid used,
- 9.2.14 Soil description in accordance with Practice D2488,
- 9.2.15 For each sample, label tubes with drill hole number and depth intervals at top and bottom and for extruded preserved cores, label the “top” and “bottom” for orientation along with the depths.

9.3 Record at a minimum the following sample data:

- 9.3.1 Surface elevation or reference to a datum to the nearest 0.1 ft [0.3 m] or better,
- 9.3.2 Drilling depths and depth to the nearest 0.1 ft [0.3 m] or better,
- 9.3.3 Depth to groundwater level: to the nearest 0.1 ft [0.3 m] or better, plus date(s) and time(s) measured,
- 9.3.4 Depth to the bottom or top of sample to the nearest 0.1 ft [0.03 m] and number of sample,

9.3.5 Length of sampler advance (push), to the nearest 0.05 ft [25 mm] or better, and

9.3.6 Recovery: length of sample obtained to the nearest 0.05 ft [25 mm] or better.

10. Keywords

10.1 geologic explorations; intact soil sampling; soil sampling; soil exploration; subsurface explorations; geotechnical exploration

APPENDIX

X1. INFORMATION REGARDING FACTORS AFFECTING THE QUALITY OF THIN-WALLED TUBE SOIL SAMPLING

(Nonmandatory Information)

X1.1 The most complete early study of soil sampling was performed by J.M. Hvorslev in 1949 (1) for the US Army Corps of Engineers (USACE). This study was comprehensive and reviewed all sampling methods including intact soil sampling. In this study he traces the origins of the thin-walled tube sampling practice and details regarding the design of thin-walled tubes to minimize disturbance of soils sampled for laboratory testing. This classic work is no longer available in print, however the USACE revised their Engineer Manual EM-1101-1-1804 in 2001 and it provides an excellent summary of this work.

X1.2 Either operator or mechanical factors affect the quality of thin-walled tube samples. Of course, the operator should use due care to properly drill the boreholes to ensure the soil is not disturbed at the base and to push the sampler at a smooth steady rate for proper sampling. Generally drilling too fast or pushing too fast can result in damage to the resulting sample.

X1.3 Mechanical factors include the sample diameter, sample push length, area ratio, Clearance Ratio, and edge cutting angle. It was clear in Hvorslev's work that large diameter samples 5 in. [125 mm] provided higher quality samples. The majority of soil sampling practice prefers the use of the smaller 3-in. [75-mm] tubes. When using these smaller tubes, more attention needs to be given to the factors listed above. If there are problems with sample quality, one should first consider going to a larger diameter sampler.

X1.4 Hvorslev defined and evaluated the Clearance ratio, C_r , of the sampler. Hvorslev suggested that C_r of 0 to 1 % may be used for very short samples, values of 0.5 to 3 % could be used for medium length samples, and larger may be needed for longer samples. If limited to a certain clearance ratio, the length of push can be shortened if there appears to be sample quality problems.

X1.5 For most soils, a C_r of 0.5 to 1.0 % can be used. C_r should be adjusted for the soil formation to be sampled. In general softer soils require lower C_r and stiffer soils require a higher C_r as they have a tendency to expand. Cohesive soils and slightly expansive soils require larger C_r , while soils with

little or no cohesion require little or no clearance ratio.

X1.6 Piston samplers are designed to sample difficult to recover non-plastic or low plasticity soils and soft to very soft clays and thus require use of C_r of 0 to 0.5 %. Use of commercially supplied tubes with 1 % clearance ratio will result in complete core loss in low plasticity soils. A smaller clearance ratio of 0 to 0.5 % must be used or piston samplers can be used. Thin-walled tubes for rotary soil core barrels such as the Pitcher Sampler used in stiff soils generally require higher C_r of 1-2 % (2). Use of a larger C_r allows for larger push lengths. The US Army Corps of Engineers uses 5 in. [125 mm] diameter piston sampler tubes pushed 4 ft [1.2 m] with commercially available 0.5 to 1 % C_r with good success in soft normally consolidated clays. Having the larger diameter core allows one to tolerate some core annulus disturbance with good specimens still in the central portion of the core. Core annulus disturbance can be evaluated in lake deposits by allowing sections of cores to dry and evaluating the lake bed layering with attention to the damage at the annulus of the sample.

X1.7 Manufacturers supply thin-walled tubes with pre-made C_r of 0.5 to 1.0 %. You must custom order other clearance ratios. If you are going to sample a soft formation you need to custom order tubes with lower clearance ratios.

X1.8 Table X1.1 below shows some recommended C_r for various soil types and moisture conditions and was included in ASTM D6169 (Table 7). These are estimates from experienced drillers and may be used as a guide but the estimates are based on large diameter samples 5-in. [125 mm] with short push lengths (2.5 ft [0.8 m]) and may not apply to smaller diameter tubes.

X1.9 Research has been conducted comparing the ASTM D1587 thin-walled tubes to other samplers used around the world. Tanaka, et al. (7) compared the ASTM thin-walled tube to other samplers including the Japanese Piston sampler, Laval Sampler and NGI samplers. The results of this research showed very poor results with ASTM 3-in. [75-mm] tubes with very low Unconfined Compression test results (D2166). There are other studies on sample quality comparing the ASTM thin-walled tube to other samplers, but all these studies neglected



TABLE X1.1 General Recommendations for Thin-Wall, Open Push-Tube Sampling

Soil type	Moisture condition	Consistency	Length of push, cm [in.]	Bit clearance ratio, %	Push tube sampler recovery	Recommendation for better recovery	
Gravel			Thin-wall, open push tube samplers not suitable				
Sand	Moist	Dense	46 [18]	0 to 1/2	Fair to poor		
Sand	Moist	Loose	30 [12]	1/2	Poor	Recommend piston sampler	
Sand	Saturated	Dense	45 to 60 [18 to 24]	0	Poor	Recommend piston sampler	
Sand	Saturated	Loose	30 to 45 [12 to 18]	0	Poor	Recommend piston sampler	
Silt	Moist	Firm	45 [18]	1/2	Fair to good		
Silt	Moist	Soft	30 to 45 [12 to 18]	1/2	Fair		
Silt	Saturated	Firm	45 to 60 [18 to 24]	0	Fair to poor	Recommend piston sampler	
Silt	Saturated	Soft	30 to 45 [12 to 18]	0 to 1/2	Poor	Recommend piston sampler	
Clay and shale	Dry to saturated	Hard	Thin wall, open push tube sampler not suitable				Recommend double-tube sampler
Clay	Moist	Firm	45 [18]	1/2 to 1	Good		
Clay	Moist	Soft	30 to 45 [12 to 18]	1	Fair to good		
Clay	Saturated	Firm	45 to 60 [18 to 24]	0 to 1	Good		
Clay	Saturated	Soft	45 to 60 [18 to 24]	1/2 to 1	Fair to poor	Recommend piston sampler	
Clay	Wet to saturated	Expansive	45 to 110 [18 to 44]	1/2 to 1-1/2	Good		

the determination of C_r of the thin-walled tubes used. Thin-walled tubes were likely purchased from manufacturers with the typical 0.5 to 1 % clearance ratio which is not recommended for soft clays.

X1.10 Lunne, et al., (8) published a study of samplers where the clearance ratios were noted. The study confirms that larger push lengths can be used successfully with higher C_r in the larger diameter the NGI sampler uses this.

X1.11 DeGroot and Landon (6) published recommendations for thin-walled tube sampling of soft clays. The recommendations stress the lower clearance ratios required for thin-walled tubes that are incorporated into this revision of the standard. Also contained in this report are recommendations by Ladd and DeGroot (4) that detail how to remove sections of the thin-walled tube without extrusion of the core.

X1.12 Evaluations of sample quality

X1.12.1 Soil samples inside the tubes can be readily evaluated for disturbance or other features such as presence of

fissures, inclusions, layering or voids using X-ray Radiography (D4452) if facilities are available. The X-ray method is excellent for checking for badly disturbed specimens and also very advantageous to locate where to cut specimens for laboratory testing. Field extrusion of soil cores and also show any indications of excessive disturbance. When performing field extrusion and preservation, do not preserve areas that are excessively damaged, only seal and wax the most intact sections of the core.

X1.12.2 In the laboratory disturbance of the soil cores and overall sample quality can be evaluated using the One-Dimensional Consolidation test (D2435) using methods proposed by Andressen and Kolstad (5). The amount of recompression up to the estimated pre-stress or existing ground stress should be small in high quality samples. Recompression in consolidated shear strength tests can also be used.

- (1) Hvorslev, M.J., 1949, Subsurface Exploration and Sampling of Soils for Engineering Purposes, report of a research project of the Committee on Sampling and Testing, Soil Mechanics and Foundations Division, American Society of Civil Engineers, Waterways Experiment Station, US Army Corps of Engineers, Vicksburg Mississippi, re-published by Engineering Foundation 1960
- (2) Engineer Manual 1101-1-1804, 2001, Geotechnical Investigations, US Army Corps of Engineers, Washington D.C. <http://140.194.76.129/publications/eng-manuals/>
- (3) Bureau of Reclamation, 1990, Earth Manual, 3rd Edition, Part 2, Test method USBR 7105 on Undisturbed Sampling of Soil by Mechanical Methods, Bureau of Reclamation, Denver CO.
- (4) Ladd, C.C., and D.J., DeGroot, "Recommended Practice for Soft Ground Site Characterization: Arthur Casagrande Lecture," 12th Pan-American Conference on Soil Mechanics and Geotechnical Engineering, Massachusetts Institute of Technology, Cambridge, MA, June 22-25, 2003, revised May 9 2004.
- (5) Andressen, A. AA., and Kolstad, P., 1979, "The NGI 154-mm

Samplers for Undisturbed Sampling of Clays and representative Sampling of Coarser Materials," State of the Art on Current Practice of Soil Sampling, Proceedings of the International Symposium of Soil Sampling, The Subcommittee on Soil Sampling, International Society for Soil Mechanics and Foundation Engineering.

- (6) DeGroot, D., J., and Landon, M., M., "Synopsis of Recommended Practice for Sampling and Handling of Soft Clays to Minimize Sample Disturbance," Geotechnical and Geophysical Site Characterization, Huang & Mayne (eds), Taylor and Francis Group, London, 2008
- (7) Tanaka, H., Sharma, P., Tsuchida, T., and Tanaka, M., "Comparative Study on Sample Quality Using Several Types of Samplers," Soils and Foundations, Vol. 36, No. 2, 57-68, June 1996
- (8) Lunne, T., Berre, T., Andersen, K.H., Strandvick, S., and M. Sjurson, (2006), "Effects of Sample Disturbance and Consolidation Procedures on Measured Shear Strength of Soft Marine Norwegian Clays, Can. Geotech. J 43: 726-750

ASTM International takes no position respecting the validity of any patent rights asserted in connection with any item mentioned in this standard. Users of this standard are expressly advised that determination of the validity of any such patent rights, and the risk of infringement of such rights, are entirely their own responsibility.

This standard is subject to revision at any time by the responsible technical committee and must be reviewed every five years and if not revised, either reapproved or withdrawn. Your comments are invited either for revision of this standard or for additional standards and should be addressed to ASTM International Headquarters. Your comments will receive careful consideration at a meeting of the responsible technical committee, which you may attend. If you feel that your comments have not received a fair hearing you should make your views known to the ASTM Committee on Standards, at the address shown below.

This standard is copyrighted by ASTM International, 100 Barr Harbor Drive, PO Box C700, West Conshohocken, PA 19428-2959, United States. Individual reprints (single or multiple copies) of this standard may be obtained by contacting ASTM at the above address or at 610-832-9585 (phone), 610-832-9555 (fax), or service@astm.org (e-mail); or through the ASTM website (www.astm.org). Permission rights to photocopy the standard may also be secured from the Copyright Clearance Center, 222 Rosewood Drive, Danvers, MA 01923, Tel: (978) 646-2600; <http://www.copyright.com/>



Designation: D1586 – 11

Standard Test Method for Standard Penetration Test (SPT) and Split-Barrel Sampling of Soils¹

This standard is issued under the fixed designation D1586; the number immediately following the designation indicates the year of original adoption or, in the case of revision, the year of last revision. A number in parentheses indicates the year of last reapproval. A superscript epsilon (ϵ) indicates an editorial change since the last revision or reapproval.

This standard has been approved for use by agencies of the U.S. Department of Defense.

1. Scope*

1.1 This test method describes the procedure, generally known as the Standard Penetration Test (SPT), for driving a split-barrel sampler to obtain a representative disturbed soil sample for identification purposes, and measure the resistance of the soil to penetration of the sampler. Another method (Test Method **D3550**) to drive a split-barrel sampler to obtain a representative soil sample is available but the hammer energy is not standardized.

1.2 Practice **D6066** gives a guide to determining the normalized penetration resistance of sands for energy adjustments of N-value to a constant energy level for evaluating liquefaction potential.

1.3 Test results and identification information are used to estimate subsurface conditions for foundation design.

1.4 Penetration resistance testing is typically performed at 5-ft depth intervals or when a significant change of materials is observed during drilling, unless otherwise specified.

1.5 This test method is limited to use in nonlithified soils and soils whose maximum particle size is approximately less than one-half of the sampler diameter.

1.6 This test method involves use of rotary drilling equipment (Guide **D5783**, Practice **D6151**). Other drilling and sampling procedures (Guide **D6286**, Guide **D6169**) are available and may be more appropriate. Considerations for hand driving or shallow sampling without boreholes are not addressed. Subsurface investigations should be recorded in accordance with Practice **D5434**. Samples should be preserved and transported in accordance with Practice **D4220** using Group B. Soil samples should be identified by group name and symbol in accordance with Practice **D2488**.

1.7 All observed and calculated values shall conform to the guidelines for significant digits and rounding established in Practice **D6026**, unless superseded by this test method.

1.8 The values stated in inch-pound units are to be regarded as standard, except as noted below. The values given in parentheses are mathematical conversions to SI units, which are provided for information only and are not considered standard.

1.8.1 The gravitational system of inch-pound units is used when dealing with inch-pound units. In this system, the pound (lbf) represents a unit of force (weight), while the unit for mass is slugs.

1.9 Penetration resistance measurements often will involve safety planning, administration, and documentation. This test method does not purport to address all aspects of exploration and site safety. *This standard does not purport to address all of the safety concerns, if any, associated with its use. It is the responsibility of the user of this standard to establish appropriate safety and health practices and determine the applicability of regulatory limitations prior to use.* Performance of the test usually involves use of a drill rig; therefore, safety requirements as outlined in applicable safety standards (for example, OSHA regulations,² NDA Drilling Safety Guide,³ drilling safety manuals, and other applicable state and local regulations) must be observed.

2. Referenced Documents

2.1 ASTM Standards:⁴

D653 Terminology Relating to Soil, Rock, and Contained Fluids

D854 Test Methods for Specific Gravity of Soil Solids by Water Pycnometer

¹ This method is under the jurisdiction of ASTM Committee **D18** on Soil and Rock and is the direct responsibility of Subcommittee **D18.02** on Sampling and Related Field Testing for Soil Evaluations.

Current edition approved Nov. 1, 2011. Published December 2011. Originally approved in 1958. Last previous edition approved in 2008 as D1586 – 08a. DOI: 10.1520/D1586-11.

² Available from Occupational Safety and Health Administration (OSHA), 200 Constitution Ave., NW, Washington, DC 20210, <http://www.osha.gov>.

³ Available from the National Drilling Association, 3511 Center Rd., Suite 8, Brunswick, OH 44212, <http://www.nda4u.com>.

⁴ For referenced ASTM standards, visit the ASTM website, www.astm.org, or contact ASTM Customer Service at service@astm.org. For *Annual Book of ASTM Standards* volume information, refer to the standard's Document Summary page on the ASTM website.

*A Summary of Changes section appears at the end of this standard

- [D1587 Practice for Thin-Walled Tube Sampling of Soils for Geotechnical Purposes](#)
- [D2216 Test Methods for Laboratory Determination of Water \(Moisture\) Content of Soil and Rock by Mass](#)
- [D2487 Practice for Classification of Soils for Engineering Purposes \(Unified Soil Classification System\)](#)
- [D2488 Practice for Description and Identification of Soils \(Visual-Manual Procedure\)](#)
- [D3550 Practice for Thick Wall, Ring-Lined, Split Barrel, Drive Sampling of Soils](#)
- [D3740 Practice for Minimum Requirements for Agencies Engaged in Testing and/or Inspection of Soil and Rock as Used in Engineering Design and Construction](#)
- [D4220 Practices for Preserving and Transporting Soil Samples](#)
- [D4633 Test Method for Energy Measurement for Dynamic Penetrometers](#)
- [D5434 Guide for Field Logging of Subsurface Explorations of Soil and Rock](#)
- [D5783 Guide for Use of Direct Rotary Drilling with Water-Based Drilling Fluid for Geoenvironmental Exploration and the Installation of Subsurface Water-Quality Monitoring Devices](#)
- [D6026 Practice for Using Significant Digits in Geotechnical Data](#)
- [D6066 Practice for Determining the Normalized Penetration Resistance of Sands for Evaluation of Liquefaction Potential](#)
- [D6151 Practice for Using Hollow-Stem Augers for Geotechnical Exploration and Soil Sampling](#)
- [D6169 Guide for Selection of Soil and Rock Sampling Devices Used With Drill Rigs for Environmental Investigations](#)
- [D6286 Guide for Selection of Drilling Methods for Environmental Site Characterization](#)
- [D6913 Test Methods for Particle-Size Distribution \(Gradation\) of Soils Using Sieve Analysis](#)

3. Terminology

3.1 Definitions:

3.1.1 Definitions of terms included in Terminology [D653](#) specific to this practice are:

3.1.2 *cathead*, *n*—the rotating drum or windlass in the rope-cathead lift system around which the operator wraps a rope to lift and drop the hammer by successively tightening and loosening the rope turns around the drum.

3.1.3 *drill rods*, *n*—rods used to transmit downward force and torque to the drill bit while drilling a borehole.

3.1.4 *N-value*, *n*—the blow count representation of the penetration resistance of the soil. The *N-value*, reported in blows per foot, equals the sum of the number of blows (*N*) required to drive the sampler over the depth interval of 6 to 18 in. (150 to 450 mm) (see [7.3](#)).

3.1.5 *Standard Penetration Test (SPT)*, *n*—a test process in the bottom of the borehole where a split-barrel sampler having an inside diameter of either 1-1/2-in. (38.1 mm) or 1-3/8-in. (34.9 mm) (see [Note 2](#)) is driven a given distance of 1.0 ft (0.30 m) after a seating interval of 0.5 ft (0.15 m) using a hammer

weighing approximately 140-lbf (623-N) falling 30 ± 1.0 in. (0.76 m \pm 0.030 m) for each hammer blow.

3.2 Definitions of Terms Specific to This Standard:

3.2.1 *anvil*, *n*—that portion of the drive-weight assembly which the hammer strikes and through which the hammer energy passes into the drill rods.

3.2.2 *drive weight assembly*, *n*—an assembly that consists of the hammer, anvil, hammer fall guide system, drill rod attachment system, and any hammer drop system hoisting attachments.

3.2.3 *hammer*, *n*—that portion of the drive-weight assembly consisting of the 140 ± 2 lbf (623 ± 9 N) impact weight which is successively lifted and dropped to provide the energy that accomplishes the sampling and penetration.

3.2.4 *hammer drop system*, *n*—that portion of the drive-weight assembly by which the operator or automatic system accomplishes the lifting and dropping of the hammer to produce the blow.

3.2.5 *hammer fall guide*, *n*—that part of the drive-weight assembly used to guide the fall of the hammer.

3.2.6 *number of rope turns*, *n*—the total contact angle between the rope and the cathead at the beginning of the operator's rope slackening to drop the hammer, divided by 360° (see [Fig. 1](#)).

3.2.7 *sampling rods*, *n*—rods that connect the drive-weight assembly to the sampler. Drill rods are often used for this purpose.

4. Significance and Use

4.1 This test method provides a disturbed soil sample for moisture content determination, for identification and classification (Practices [D2487](#) and [D2488](#)) purposes, and for laboratory tests appropriate for soil obtained from a sampler that will produce large shear strain disturbance in the sample such as Test Methods [D854](#), [D2216](#), and [D6913](#). Soil deposits containing gravels, cobbles, or boulders typically result in penetration refusal and damage to the equipment.

4.2 This test method provides a disturbed soil sample for moisture content determination and laboratory identification. Sample quality is generally not suitable for advanced laboratory testing for engineering properties. The process of driving the sampler will cause disturbance of the soil and change the engineering properties. Use of the thin wall tube sampler (Practice [D1587](#)) may result in less disturbance in soft soils. Coring techniques may result in less disturbance than SPT sampling for harder soils, but it is not always the case, that is, some cemented soils may become loosened by water action during coring; see Practice [D6151](#), and Guide [D6169](#).

4.3 This test method is used extensively in a great variety of geotechnical exploration projects. Many local correlations and widely published correlations which relate blow count, or *N-value*, and the engineering behavior of earthworks and foundations are available. For evaluating the liquefaction potential of sands during an earthquake event, the *N-value* should be normalized to a standard overburden stress level. Practice [D6066](#) provides methods to obtain a record of

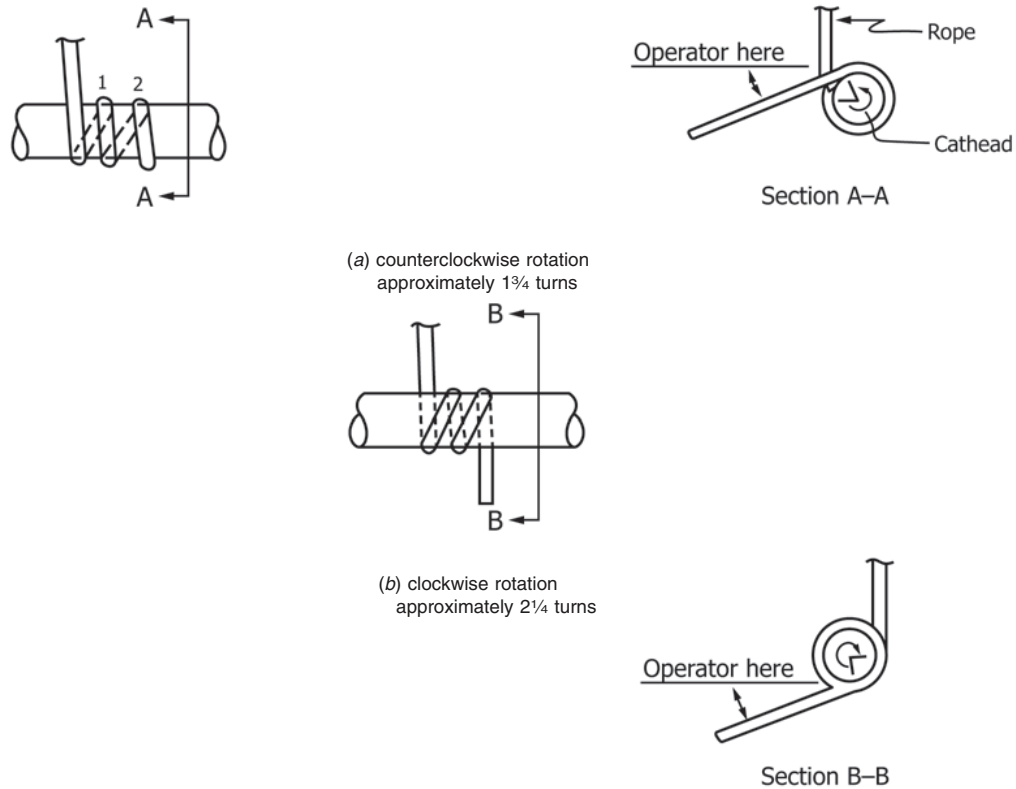

FIG. 1 Definitions of the Number of Rope Turns and the Angle for (a) Counterclockwise Rotation and (b) Clockwise Rotation of the Cathead

normalized resistance of sands to the penetration of a standard sampler driven by a standard energy. The penetration resistance is adjusted to drill rod energy ratio of 60 % by using a hammer system with either an estimated energy delivery or directly measuring drill rod stress wave energy using Test Method D4633.

NOTE 1—The reliability of data and interpretations generated by this practice is dependent on the competence of the personnel performing it and the suitability of the equipment and facilities used. Agencies that meet the criteria of Practice D3740 generally are considered capable of competent testing. Users of this practice are cautioned that compliance with Practice D3740 does not assure reliable testing. Reliable testing depends on several factors and Practice D3740 provides a means of evaluating some of these factors. Practice D3740 was developed for agencies engaged in the testing, inspection, or both, of soils and rock. As such, it is not totally applicable to agencies performing this practice. Users of this test method should recognize that the framework of Practice D3740 is appropriate for evaluating the quality of an agency performing this test method. Currently, there is no known qualifying national authority that inspects agencies that perform this test method.

5. Apparatus

5.1 *Drilling Equipment*—Any drilling equipment that provides at the time of sampling a suitable borehole before insertion of the sampler and ensures that the penetration test is performed on intact soil shall be acceptable. The following pieces of equipment have proven to be suitable for advancing a borehole in some subsurface conditions:

5.1.1 *Drag, Chopping, and Fishtail Bits*, less than 6½ in. (165 mm) and greater than 2¼ in. (57 mm) in diameter may be used in conjunction with open-hole rotary drilling or casing-advancement drilling methods. To avoid disturbance of the underlying soil, bottom discharge bits are not permitted; only side discharge bits are permitted.

5.1.2 *Roller-Cone Bits*, less than 6½ in. (165 mm) and greater than 2¼ in. (57 mm) in diameter may be used in conjunction with open-hole rotary drilling or casing-advancement drilling methods if the drilling fluid discharge is deflected.

5.1.3 *Hollow-Stem Continuous Flight Augers*, with or without a center bit assembly, may be used to drill the borehole. The inside diameter of the hollow-stem augers shall be less than 6½ in. (165 mm) and not less than 2¼ in. (57 mm).

5.1.4 *Solid, Continuous Flight, Bucket and Hand Augers*, less than 6½ in. (165 mm) and not less than 2¼ in. (57 mm) in diameter may be used if the soil on the side of the borehole does not cave onto the sampler or sampling rods during sampling.

5.2 *Sampling Rods*—Flush-joint steel drill rods shall be used to connect the split-barrel sampler to the drive-weight assembly. The sampling rod shall have a stiffness (moment of inertia) equal to or greater than that of parallel wall “A” rod (a steel rod that has an outside diameter of 1-5/8 in. (41.3 mm) and an inside diameter of 1-1/8 in. (28.5 mm)).

5.3 Split-Barrel Sampler—The standard sampler dimensions are shown in Fig. 2. The sampler has an outside diameter of 2.00 in. (50.8 mm). The inside diameter of the of the split-barrel (dimension D in Fig. 2) can be either 1½-in. (38.1 mm) or 1⅜-in. (34.9 mm) (see Note 2). A 16-gauge liner can be used inside the 1½-in. (38.1 mm) split barrel sampler. The driving shoe shall be of hardened steel and shall be replaced or repaired when it becomes dented or distorted. The penetrating end of the drive shoe may be slightly rounded. The split-barrel sampler must be equipped with a ball check and vent. Metal or plastic baskets may be used to retain soil samples.

NOTE 2—Both theory and available test data suggest that *N*-values may differ as much as 10 to 30 % between a constant inside diameter sampler and upset wall sampler. If it is necessary to correct for the upset wall sampler refer to Practice D6066. In North America, it is now common practice to use an upset wall sampler with an inside diameter of 1½ in. At one time, liners were used but practice evolved to use the upset wall sampler without liners. Use of an upset wall sampler allows for use of retainers if needed, reduces inside friction, and improves recovery. Many other countries still use a constant ID split-barrel sampler, which was the original standard and still acceptable within this standard.

5.4 Drive-Weight Assembly:

5.4.1 Hammer and Anvil—The hammer shall weigh 140 ± 2 lbf (623 ± 9 N) and shall be a rigid metallic mass. The hammer shall strike the anvil and make steel on steel contact when it is dropped. A hammer fall guide permitting an unimpeded fall shall be used. Fig. 3 shows a schematic of such hammers. Hammers used with the cathead and rope method shall have an unimpeded over lift capacity of at least 4 in. (100 mm). For safety reasons, the use of a hammer assembly with an internal anvil is encouraged as shown in Fig. 3. The total mass

of the hammer assembly bearing on the drill rods should not be more than 250 ± 10 lbf (113 ± 5 kg).

NOTE 3—It is suggested that the hammer fall guide be permanently marked to enable the operator or inspector to judge the hammer drop height.

5.4.2 Hammer Drop System—Rope-cathead, trip, semi-automatic or automatic hammer drop systems may be used, providing the lifting apparatus will not cause penetration of the sampler while re-engaging and lifting the hammer.

5.5 Accessory Equipment—Accessories such as labels, sample containers, data sheets, and groundwater level measuring devices shall be provided in accordance with the requirements of the project and other ASTM standards.

6. Drilling Procedure

6.1 The borehole shall be advanced incrementally to permit intermittent or continuous sampling. Test intervals and locations are normally stipulated by the project engineer or geologist. Typically, the intervals selected are 5 ft (1.5 m) or less in homogeneous strata with test and sampling locations at every change of strata. Record the depth of drilling to the nearest 0.1 ft (0.030 m).

6.2 Any drilling procedure that provides a suitably clean and stable borehole before insertion of the sampler and assures that the penetration test is performed on essentially intact soil shall be acceptable. Each of the following procedures has proven to be acceptable for some subsurface conditions. The subsurface conditions anticipated should be considered when selecting the drilling method to be used.

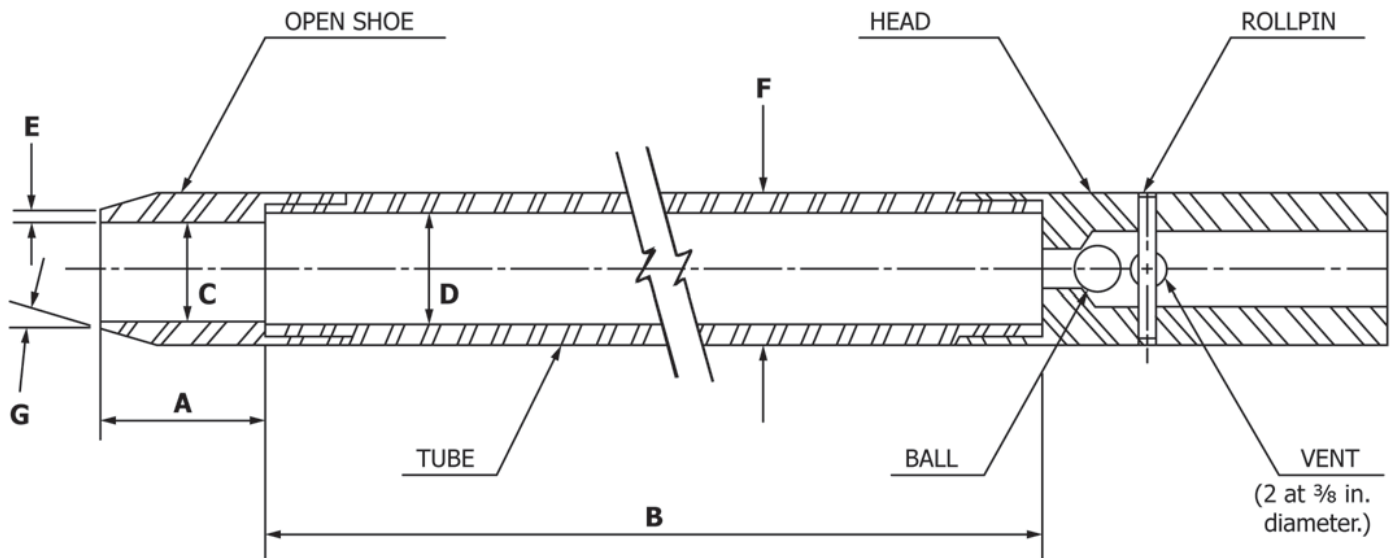

- A = 1.0 to 2.0 in. (25 to 50 mm)
- B = 18.0 to 30.0 in. (0.457 to 0.762 m)
- C = 1.375 ± 0.005 in. (34.93 ± 0.13 mm)
- D = 1.50 ± 0.05 – 0.00 in. (38.1 ± 1.3 – 0.0 mm)
- E = 0.10 ± 0.02 in. (2.54 ± 0.25 mm)
- F = 2.00 ± 0.05 – 0.00 in. (50.8 ± 1.3 – 0.0 mm)
- G = 16.0° to 23.0°

FIG. 2 Split-Barrel Sampler

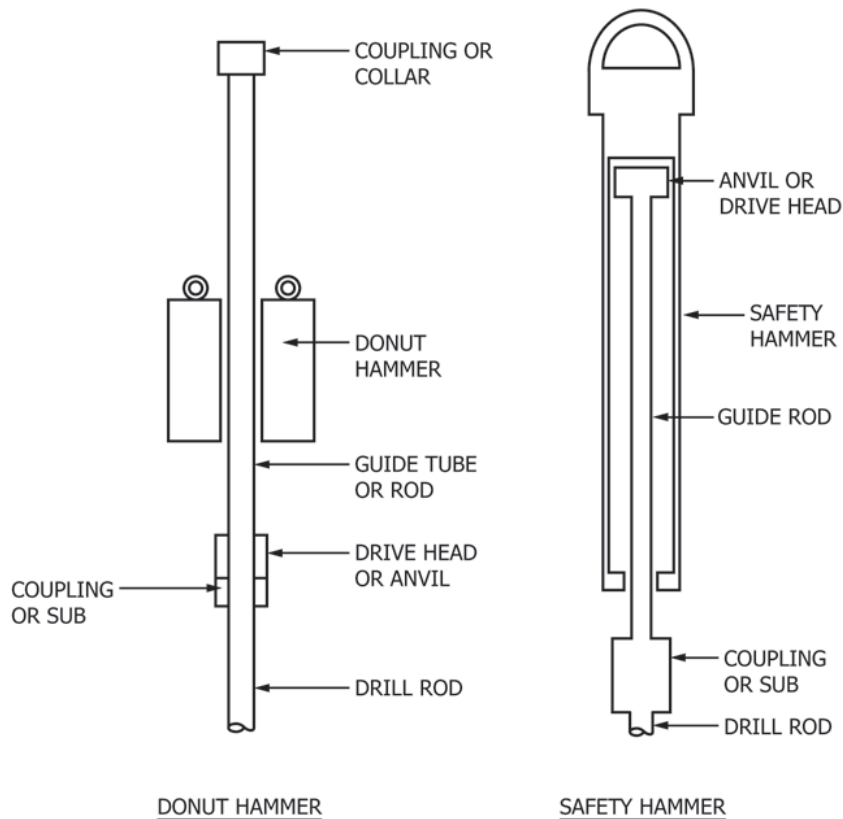

FIG. 3 Schematic Drawing of the Donut Hammer and Safety Hammer

- 6.2.1 Open-hole rotary drilling method.
- 6.2.2 Continuous flight hollow-stem auger method.
- 6.2.3 Wash boring method.
- 6.2.4 Continuous flight solid auger method.

6.3 Several drilling methods produce unacceptable boreholes. The process of jetting through an open tube sampler and then sampling when the desired depth is reached shall not be permitted. The continuous flight solid auger method shall not be used for advancing the borehole below a water table or below the upper confining bed of a confined non-cohesive stratum that is under artesian pressure. Casing may not be advanced below the sampling elevation prior to sampling. Advancing a borehole with bottom discharge bits is not permissible. It is not permissible to advance the borehole for subsequent insertion of the sampler solely by means of previous sampling with the SPT sampler.

6.4 The drilling fluid level within the borehole or hollow-stem augers shall be maintained at or above the in situ groundwater level at all times during drilling, removal of drill rods, and sampling.

7. Sampling and Testing Procedure

7.1 After the borehole has been advanced to the desired sampling elevation and excessive cuttings have been removed, record the cleanout depth to the nearest 0.1 ft (0.030 m), and prepare for the test with the following sequence of operations:

7.1.1 Attach either split-barrel sampler Type A or B to the sampling rods and lower into the borehole. Do not allow the sampler to drop onto the soil to be sampled.

7.1.2 Position the hammer above and attach the anvil to the top of the sampling rods. This may be done before the sampling rods and sampler are lowered into the borehole.

7.1.3 Rest the dead weight of the sampler, rods, anvil, and drive weight on the bottom of the borehole. Record the sampling start depth to the nearest 0.1 ft (0.030 m). Compare the sampling start depth to the cleanout depth in 7.1. If excessive cuttings are encountered at the bottom of the borehole, remove the sampler and sampling rods from the borehole and remove the cuttings.

7.1.4 Mark the drill rods in three successive 0.5-ft (0.15 m) increments so that the advance of the sampler under the impact of the hammer can be easily observed for each 0.5-ft (0.15 m) increment.

7.2 Drive the sampler with blows from the 140-lbf (623-N) hammer and count the number of blows applied in each 0.5-ft (0.15-m) increment until one of the following occurs:

- 7.2.1 A total of 50 blows have been applied during any one of the three 0.5-ft (0.15-m) increments described in 7.1.4.
- 7.2.2 A total of 100 blows have been applied.
- 7.2.3 There is no observed advance of the sampler during the application of 10 successive blows of the hammer.

7.2.4 The sampler is advanced the complete 1.5 ft. (0.45 m) without the limiting blow counts occurring as described in 7.2.1, 7.2.2, or 7.2.3.

7.2.5 If the sampler sinks under the weight of the hammer, weight of rods, or both, record the length of travel to the nearest 0.1 ft (0.030 m), and drive the sampler through the remainder of the test interval. If the sampler sinks the complete interval, stop the penetration, remove the sampler and sampling rods from the borehole, and advance the borehole through the very soft or very loose materials to the next desired sampling elevation. Record the *N*-value as either weight of hammer, weight of rods, or both.

7.3 Record the number of blows (*N*) required to advance the sampler each 0.5-ft (0.15 m) of penetration or fraction thereof. The first 0.5-ft (0.15 m) is considered to be a seating drive. The sum of the number of blows required for the second and third 0.5-ft (0.15 m) of penetration is termed the “standard penetration resistance,” or the “*N*-value.” If the sampler is driven less than 1.5 ft (0.45 m), as permitted in 7.2.1, 7.2.2, or 7.2.3, the number of blows per each complete 0.5-ft (0.15 m) increment and per each partial increment shall be recorded on the boring log. For partial increments, the depth of penetration shall be reported to the nearest 0.1 ft (0.030 m) in addition to the number of blows. If the sampler advances below the bottom of the borehole under the static weight of the drill rods or the weight of the drill rods plus the static weight of the hammer, this information should be noted on the boring log.

7.4 The raising and dropping of the 140-lbf (623-N) hammer shall be accomplished using either of the following two methods. Energy delivered to the drill rod by either method can be measured according to procedures in Test Method D4633.

7.4.1 *Method A*—By using a trip, automatic, or semi-automatic hammer drop system that lifts the 140-lbf (623-N) hammer and allows it to drop 30 ± 1.0 in. ($0.76 \text{ m} \pm 0.030$ m) with limited unimpedence. Drop heights adjustments for automatic and trip hammers should be checked daily and at first indication of variations in performance. Operation of automatic hammers shall be in strict accordance with operations manuals.

7.4.2 *Method B*—By using a cathead to pull a rope attached to the hammer. When the cathead and rope method is used the system and operation shall conform to the following:

7.4.2.1 The cathead shall be essentially free of rust, oil, or grease and have a diameter in the range of 6 to 10 in. (150 to 250 mm).

7.4.2.2 The cathead should be operated at a minimum speed of rotation of 100 RPM.

7.4.2.3 The operator should generally use either 1-3/4 or 2-1/4 rope turns on the cathead, depending upon whether or not the rope comes off the top (1-3/4 turns for counterclockwise rotation) or the bottom (2-1/4 turns for clockwise rotation) of the cathead during the performance of the penetration test, as shown in Fig. 1. It is generally known and accepted that 2-3/4 or more rope turns considerably impedes the fall of the hammer and should not be used to perform the test. The cathead rope should be stiff, relatively dry, clean, and should be replaced when it becomes excessively frayed, oily, limp, or burned.

7.4.2.4 For each hammer blow, a 30 ± 1.0 in. ($0.76 \text{ m} \pm 0.030$ m) lift and drop shall be employed by the operator. The

operation of pulling and throwing the rope shall be performed rhythmically without holding the rope at the top of the stroke.

NOTE 4—If the hammer drop height is something other than 30 ± 1.0 in. ($0.76 \text{ m} \pm 0.030$ m), then record the new drop height. For soils other than sands, there is no known data or research that relates to adjusting the *N*-value obtained from different drop heights. Test method D4633 provides information on making energy measurement for variable drop heights and Practice D6066 provides information on adjustment of *N*-value to a constant energy level (60 % of theoretical, *N*60). Practice D6066 allows the hammer drop height to be adjusted to provide 60 % energy.

7.5 Bring the sampler to the surface and open. Record the percent recovery to the nearest 1 % or the length of sample recovered to the nearest 0.1 ft (30 mm). Classify the soil samples recovered as to, in accordance with Practice D2488, then place one or more representative portions of the sample into sealable moisture-proof containers (jars) without ramming or distorting any apparent stratification. Seal each container to prevent evaporation of soil moisture. Affix labels to the containers bearing job designation, boring number, sample depth, and the blow count per 0.5-ft (150-mm) increment. Protect the samples against extreme temperature changes. If there is a soil change within the sampler, make a jar for each stratum and note its location in the sampler barrel. Samples should be preserved and transported in accordance with Practice D4220 using Group B.

8. Data Sheet(s)/Form(s)

8.1 Data obtained in each borehole shall be recorded in accordance with the Subsurface Logging Guide D5434 as required by the exploration program. An example of a sample data sheet is included in Appendix X1.

8.2 Drilling information shall be recorded in the field and shall include the following:

- 8.2.1 Name and location of job,
- 8.2.2 Names of crew,
- 8.2.3 Type and make of drilling machine,
- 8.2.4 Weather conditions,
- 8.2.5 Date and time of start and finish of borehole,
- 8.2.6 Boring number and location (station and coordinates, if available and applicable),
- 8.2.7 Surface elevation, if available,
- 8.2.8 Method of advancing and cleaning the borehole,
- 8.2.9 Method of keeping borehole open,
- 8.2.10 Depth of water surface to the nearest 0.1 ft (30 mm) and drilling depth to the nearest 0.1 ft (30 mm) at the time of a noted loss of drilling fluid, and time and date when reading or notation was made,
- 8.2.11 Location of strata changes, to the nearest 0.5 ft (150 mm),
- 8.2.12 Size of casing, depth of cased portion of borehole to the nearest 0.1 ft (30 mm),
- 8.2.13 Equipment and Method A or B of driving sampler,
- 8.2.14 Sampler length and inside diameter of barrel, and if a sample basket retainer is used,
- 8.2.15 Size, type, and section length of the sampling rods, and
- 8.2.16 Remarks.

8.3 Data obtained for each sample shall be recorded in the field and shall include the following:

8.3.1 Top of sample depth to the nearest 0.1 ft (30 mm) and, if utilized, the sample number,

8.3.2 Description of soil,

8.3.3 Strata changes within sample,

8.3.4 Sampler penetration and recovery lengths to the nearest 0.1 ft (30 mm), and

8.3.5 Number of blows per 0.5 ft (150 mm) or partial increment.

9. Precision and Bias

9.1 *Precision*—Test data on precision is not presented due to the nature of this test method. It is either not feasible or too costly at this time to have ten or more agencies participate in an in situ testing program at a given site.

9.1.1 The Subcommittee 18.02 is seeking additional data from the users of this test method that might be used to make a limited statement on precision. Present knowledge indicates the following:

9.1.1.1 Variations in N -values of 100 % or more have been observed when using different standard penetration test apparatus and drillers for adjacent boreholes in the same soil formation. Current opinion, based on field experience, indicates that when using the same apparatus and driller, N -values in the same soil can be reproduced with a coefficient of variation of about 10 %.

9.1.1.2 The use of faulty equipment, such as an extremely massive or damaged anvil, a rusty cathead, a low speed cathead, an old, oily rope, or massive or poorly lubricated rope sheaves can significantly contribute to differences in N -values obtained between operator-drill rig systems.

9.2 *Bias*—There is no accepted reference value for this test method, therefore, bias cannot be determined.

10. Keywords

10.1 blow count; in-situ test; penetration resistance; soil; split-barrel sampling; standard penetration test

APPENDIX

(Nonmandatory Information)

X1. EXAMPLE DATA SHEET

X1.1 See [Fig. X1.1](#).

SUMMARY OF CHANGES

Committee D18 has identified the location of selected changes to this test method since the last issue, D1586–08a, that may impact the use of this test method. (Approved November 1, 2011.)

(I) Corrected misuse of significant digits.

ASTM International takes no position respecting the validity of any patent rights asserted in connection with any item mentioned in this standard. Users of this standard are expressly advised that determination of the validity of any such patent rights, and the risk of infringement of such rights, are entirely their own responsibility.

This standard is subject to revision at any time by the responsible technical committee and must be reviewed every five years and if not revised, either reapproved or withdrawn. Your comments are invited either for revision of this standard or for additional standards and should be addressed to ASTM International Headquarters. Your comments will receive careful consideration at a meeting of the responsible technical committee, which you may attend. If you feel that your comments have not received a fair hearing you should make your views known to the ASTM Committee on Standards, at the address shown below.

This standard is copyrighted by ASTM International, 100 Barr Harbor Drive, PO Box C700, West Conshohocken, PA 19428-2959, United States. Individual reprints (single or multiple copies) of this standard may be obtained by contacting ASTM at the above address or at 610-832-9585 (phone), 610-832-9555 (fax), or service@astm.org (e-mail); or through the ASTM website (www.astm.org). Permission rights to photocopy the standard may also be secured from the Copyright Clearance Center, 222 Rosewood Drive, Danvers, MA 01923, Tel: (978) 646-2600; <http://www.copyright.com/>

Appendix D.
Corrective Action Report

Corrective Action Report/ Corrective Action Plan

Project ID	Project Name	Document ID
Preparer's Signature/Submit Date		Submitted to:
Description of the requirement or specification		
Reason for the Corrective Action		
Location, affected sample, affected equipment, etc. requiring corrective action		
Suggested Corrective Action	(Continue on Back)	
Corrective Action Plan	(Continue on Back)	
	<input type="checkbox"/> Approval signature/date: _____	
	Approval of corrective actions required by EPA? <input type="checkbox"/> Yes <input type="checkbox"/> No	
	<input type="checkbox"/> EPA approval name/date: _____ <input type="checkbox"/> Corrective actions completed name/date: _____	
Preventative Action Plan	(Continue on Back)	
	<input type="checkbox"/> Preventative actions completed name/date: _____	

Corrective Action Report/ Corrective Action Plan

**Suggested Corrective Action
(Continued)**

**Corrective Action Plan
(Continued)**

**Preventative Action Plan
(Continued)**

Appendix E. Data Validation

Stage 2A Data Validation Checklist for Metals Sample Analysis

Site:	Case No:	Laboratory:
Project:	Sample Matrix:	Analyses:
Sample Date(s):	Analysis Date(s):	
Data Validator:	Validation Date(s):	

1. Holding Times

Analyte	Laboratory	Matrix	Method	Holding Times	Collection Date(s):	Analysis Date(s)	Holding Time Met (Y/N)	Affected Data Flagged (Y/N)

Were any data flagged because of holding time? Y N

Were any data flagged because of preservation problems? Y N

Describe Any Actions Taken:

Comments:

2. Blanks

Were Method Blanks (MBs) analyzed at the frequency of 1 per analytical batch?	Y <input type="checkbox"/>	N <input type="checkbox"/>
Were MBs within the control window?	Y <input type="checkbox"/>	N <input type="checkbox"/>
Were any data flagged because of blank problems?	Y <input type="checkbox"/>	N <input type="checkbox"/>
Describe Any Actions Taken:		
Comments:		

3. Laboratory Control Samples

Were Laboratory Control Samples (LCS) analyzed at the frequency of 1 per batch?	Y <input type="checkbox"/>	N <input type="checkbox"/>
Were LCS results within the control window?	Y <input type="checkbox"/>	N <input type="checkbox"/>
Were any data flagged because of LCS problems?	Y <input type="checkbox"/>	N <input type="checkbox"/>
Describe Any Actions Taken:		
Comments:		

4. Duplicate Sample Results

Were Laboratory Duplicate Samples (LDS) analyzed at the frequency of 1 per batch?	Y <input type="checkbox"/>	N <input type="checkbox"/>
Were LDS results within the control window?	Y <input type="checkbox"/>	N <input type="checkbox"/>
Were any data flagged because of LDS problems?	Y <input type="checkbox"/>	N <input type="checkbox"/>
Describe Any Actions Taken:		
Comments:		

5. Matrix Spike Sample Results

Were Laboratory Matrix Spike Samples (LMS) analyzed at the frequency of 1 per batch?	Y <input type="checkbox"/>	N <input type="checkbox"/>
Were LMS results within the control window?	Y <input type="checkbox"/>	N <input type="checkbox"/>
Were any data flagged because of LMS problems?	Y <input type="checkbox"/>	N <input type="checkbox"/>
Describe Any Actions Taken:		
Comments:		

6. ICP Serial Dilutions

Were ICP Serial Dilutions (SD) analyzed at the frequency of 1 per batch?	Y	<input type="checkbox"/>	N	<input type="checkbox"/>	
Were SD percent differences (%D) results within the control window?	Y	<input type="checkbox"/>	N	<input type="checkbox"/>	
Were any data flagged because of SD problems?	Y	<input type="checkbox"/>	N	<input type="checkbox"/>	
Describe Any Actions Taken:					
Comments:					

7. Field Blanks

Were field blanks submitted as specified in the QAPP?	Y	<input type="checkbox"/>	N	<input type="checkbox"/>	N/A	<input type="checkbox"/>
Were field blanks within the control window?	Y	<input type="checkbox"/>	N	<input type="checkbox"/>	N/A	<input type="checkbox"/>
Were any data qualified because of field blank problems?	Y	<input type="checkbox"/>	N	<input type="checkbox"/>	N/A	<input type="checkbox"/>
Describe Any Actions Taken:						
Comments:						

8. Field Duplicates

Were field duplicates submitted as specified in the QAPP?	Y	<input type="checkbox"/>	N	<input type="checkbox"/>	N/A	<input type="checkbox"/>
Were results for field duplicates within the control window?	Y	<input type="checkbox"/>	N	<input type="checkbox"/>	N/A	<input type="checkbox"/>
Were any data qualified because of field duplicate problems?	Y	<input type="checkbox"/>	N	<input type="checkbox"/>	N/A	<input type="checkbox"/>
Describe Any Actions Taken:						
Comments:						

9. Overall Assessment

Are there analytical limitations of the data that users should be aware of?	Y	<input type="checkbox"/>	N	<input type="checkbox"/>	
If so, explain:					
Comments:					

10. Authorization of Data Validation

Data Validator Name: _____ Signature: _____ Date: _____	Reviewed by: _____ _____
---	---

Stage 2A Data Validation Checklist for General Chemistry Sample Analysis

Site:	Case No:	Laboratory:
Project:	Sample Matrix:	Analyses:
Sample Date(s):	Analysis Date(s):	
Data Validator:	Validation Date(s):	

1. Holding Times

Analyte	Laboratory	Matrix	Method	Holding Times	Collection Date(s):	Analysis Date(s)	Holding Time Met (Y/N)	Affected Data Flagged (Y/N)

Were any data flagged because of holding time? Y N

Were any data flagged because of preservation problems? Y N

Describe Any Actions Taken:

Comments:

2. Blanks

Were Method Blanks (MBs) analyzed at the frequency of 1 per analytical batch?	Y <input type="checkbox"/>	N <input type="checkbox"/>
Were MBs within the control window?	Y <input type="checkbox"/>	N <input type="checkbox"/>
Were any data flagged because of blank problems?	Y <input type="checkbox"/>	N <input type="checkbox"/>
Describe Any Actions Taken:		
Comments:		

3. Laboratory Control Samples

Were Laboratory Control Samples (LCS) analyzed at the frequency of 1 per batch?	Y <input type="checkbox"/>	N <input type="checkbox"/>
Were LCS results within the control window?	Y <input type="checkbox"/>	N <input type="checkbox"/>
Were any data flagged because of LCS problems?	Y <input type="checkbox"/>	N <input type="checkbox"/>
Describe Any Actions Taken:		
Comments:		

4. Duplicate Sample Results

Were Laboratory Duplicate Samples (LDS) analyzed at the frequency of 1 per batch?	Y <input type="checkbox"/>	N <input type="checkbox"/>
Were LDS results within the control window?	Y <input type="checkbox"/>	N <input type="checkbox"/>
Were any data flagged because of LDS problems?	Y <input type="checkbox"/>	N <input type="checkbox"/>
Describe Any Actions Taken:		
Comments:		

5. Matrix Spike Sample Results

Were Laboratory Matrix Spike Samples (LMS) analyzed at the frequency of 1 per batch?	Y <input type="checkbox"/>	N <input type="checkbox"/>
Were LMS results within the control window?	Y <input type="checkbox"/>	N <input type="checkbox"/>
Were any data flagged because of LMS problems?	Y <input type="checkbox"/>	N <input type="checkbox"/>
Describe Any Actions Taken:		
Comments:		

6. Field Blanks

Were field blanks submitted as specified in the QAPP?	Y	<input type="checkbox"/>	N	<input type="checkbox"/>	N/A	<input type="checkbox"/>
Were field blanks within the control window?	Y	<input type="checkbox"/>	N	<input type="checkbox"/>	N/A	<input type="checkbox"/>
Were any data qualified because of field blank problems?	Y	<input type="checkbox"/>	N	<input type="checkbox"/>	N/A	<input type="checkbox"/>
Describe Any Actions Taken:						
Comments:						

7. Field Duplicates

Were field duplicates submitted as specified in the QAPP?	Y	<input type="checkbox"/>	N	<input type="checkbox"/>	N/A	<input type="checkbox"/>
Were results for field duplicates within the control window?	Y	<input type="checkbox"/>	N	<input type="checkbox"/>	N/A	<input type="checkbox"/>
Were any data qualified because of field duplicate problems?	Y	<input type="checkbox"/>	N	<input type="checkbox"/>	N/A	<input type="checkbox"/>
Describe Any Actions Taken:						
Comments:						

8. Overall Assessment

Are there analytical limitations of the data that users should be aware of?	Y	<input type="checkbox"/>	N	<input type="checkbox"/>
If so, explain:				
Comments:				

9. Authorization of Data Validation

Data Validator Name: _____ Signature: _____ Date: _____	Reviewed by: _____ _____ _____
---	---

Site:	Case No:	Laboratory:
Project:	Sample Matrix:	Analyses:
Sample Date(s):	Analysis Date(s):	
Data Validator:	Validation Date(s):	

1. Holding Times

Analyte	Laboratory	Matrix	Method	Holding Times	Collection Date(s):	Analysis Date(s)	Holding Time Met (Y/N)	Affected Data Flagged (Y/N)

Were any data flagged because of holding time? Y N

Were any data flagged because of preservation problems? Y N

Describe Any Actions Taken:

Comments:

2. Blanks

Were Method Blanks (MBs) analyzed at the frequency of 1 per analytical batch? Y N

Were MBs within the control window? Y N

Were any data flagged because of blank problems? Y N

Describe Any Actions Taken:

Comments:

3. Surrogates

Were surrogates present in all extracted samples (including QC)? Y N

Were surrogate recoveries within the control window? Y N

Were any data flagged because of surrogate problems? Y N

Describe Any Actions Taken:

Comments:

4. Laboratory Control Samples

Were Laboratory Control Samples (LCS) analyzed at the frequency of 1 per batch? Y N

Were LCS results within the control window? Y N

Were any data flagged because of LCS problems? Y N

Describe Any Actions Taken:

Comments:

5. Duplicate Sample Results

Were Laboratory Duplicate Samples (LDS) analyzed at the frequency of 1 per batch? Y N

Were LDS results within the control window? Y N

Were any data flagged because of LDS problems? Y N

Describe Any Actions Taken:

Comments:

6. Matrix Spike Sample Results

Were Laboratory Matrix Spike Samples (LMS) analyzed at the frequency of 1 per batch?	Y	<input type="checkbox"/>	N	<input type="checkbox"/>
Were LMS results within the control window?	Y	<input type="checkbox"/>	N	<input type="checkbox"/>
Were any data flagged because of LMS problems?	Y	<input type="checkbox"/>	N	<input type="checkbox"/>
Describe Any Actions Taken:				
Comments:				

7. Field Blanks

Were field blanks submitted as specified in the QAPP?	Y	<input type="checkbox"/>	N	<input type="checkbox"/>	N/A	<input type="checkbox"/>
Were field blanks within the control window?	Y	<input type="checkbox"/>	N	<input type="checkbox"/>	N/A	<input type="checkbox"/>
Were any data qualified because of field blank problems?	Y	<input type="checkbox"/>	N	<input type="checkbox"/>	N/A	<input type="checkbox"/>
Describe Any Actions Taken:						
Comments:						

8. Field Duplicates

Were field duplicates submitted as specified in the QAPP?	Y	<input type="checkbox"/>	N	<input type="checkbox"/>	N/A	<input type="checkbox"/>
Were results for field duplicates within the control window?	Y	<input type="checkbox"/>	N	<input type="checkbox"/>	N/A	<input type="checkbox"/>
Were any data qualified because of field duplicate problems?	Y	<input type="checkbox"/>	N	<input type="checkbox"/>	N/A	<input type="checkbox"/>
Describe Any Actions Taken:						
Comments:						

9. Overall Assessment

Are there analytical limitations of the data that users should be aware of?	Y	<input type="checkbox"/>	N	<input type="checkbox"/>
If so, explain:				
Comments:				

10. Authorization of Data Validation

Data Validator Name: _____	Reviewed by: _____
Signature: _____	_____
Date: _____	_____

Stage 2A Data Validation Checklist for Organics (GC-MS) Sample Analysis

Site:	Case No:	Laboratory:
Project:	Sample Matrix:	Analyses:
Sample Date(s):	Analysis Date(s):	
Data Validator:	Validation Date(s):	

1. Holding Times

Analyte	Laboratory	Matrix	Method	Holding Times	Collection Date(s):	Analysis Date(s)	Holding Time Met (Y/N)	Affected Data Flagged (Y/N)

Were any data flagged because of holding time? Y N

Were any data flagged because of preservation problems? Y N

Describe Any Actions Taken:

Comments:

2. Blanks

Were Method Blanks (MBs) analyzed at the frequency of 1 per analytical batch?	Y <input type="checkbox"/>	N <input type="checkbox"/>
Were MBs within the control window?	Y <input type="checkbox"/>	N <input type="checkbox"/>
Were any data flagged because of blank problems?	Y <input type="checkbox"/>	N <input type="checkbox"/>
Describe Any Actions Taken:		
Comments:		

3. Surrogates

Were surrogates present in all extracted samples (including QC)?	Y <input type="checkbox"/>	N <input type="checkbox"/>
Were surrogate recoveries within the control window?	Y <input type="checkbox"/>	N <input type="checkbox"/>
Were any data flagged because of surrogate problems?	Y <input type="checkbox"/>	N <input type="checkbox"/>
Describe Any Actions Taken:		
Comments:		

4. Laboratory Control Samples

Were Laboratory Control Samples (LCS) analyzed at the frequency of 1 per batch?	Y <input type="checkbox"/>	N <input type="checkbox"/>
Were LCS results within the control window?	Y <input type="checkbox"/>	N <input type="checkbox"/>
Were any data flagged because of LCS problems?	Y <input type="checkbox"/>	N <input type="checkbox"/>
Describe Any Actions Taken:		
Comments:		

5. Duplicate Sample Results

Were Laboratory Duplicate Samples (LDS) analyzed at the frequency of 1 per batch?	Y <input type="checkbox"/>	N <input type="checkbox"/>
Were LDS results within the control window?	Y <input type="checkbox"/>	N <input type="checkbox"/>
Were any data flagged because of LDS problems?	Y <input type="checkbox"/>	N <input type="checkbox"/>
Describe Any Actions Taken:		
Comments:		

6. Matrix Spike Sample Results

Were Laboratory Matrix Spike Samples (LMS) analyzed at the frequency of 1 per batch?	Y	<input type="checkbox"/>	N	<input type="checkbox"/>	
Were LMS results within the control window?	Y	<input type="checkbox"/>	N	<input type="checkbox"/>	
Were any data flagged because of LMS problems?	Y	<input type="checkbox"/>	N	<input type="checkbox"/>	
Describe Any Actions Taken:					
Comments:					

7. Field Blanks

Were field blanks submitted as specified in the QAPP?	Y	<input type="checkbox"/>	N	<input type="checkbox"/>	N/A	<input type="checkbox"/>
Were field blanks within the control window?	Y	<input type="checkbox"/>	N	<input type="checkbox"/>	N/A	<input type="checkbox"/>
Were any data qualified because of field blank problems?	Y	<input type="checkbox"/>	N	<input type="checkbox"/>	N/A	<input type="checkbox"/>
Describe Any Actions Taken:						
Comments:						

8. Field Duplicates

Were field duplicates submitted as specified in the QAPP?	Y	<input type="checkbox"/>	N	<input type="checkbox"/>	N/A	<input type="checkbox"/>
Were results for field duplicates within the control window?	Y	<input type="checkbox"/>	N	<input type="checkbox"/>	N/A	<input type="checkbox"/>
Were any data qualified because of field duplicate problems?	Y	<input type="checkbox"/>	N	<input type="checkbox"/>	N/A	<input type="checkbox"/>
Describe Any Actions Taken:						
Comments:						

9. Overall Assessment

Are there analytical limitations of the data that users should be aware of?	Y	<input type="checkbox"/>	N	<input type="checkbox"/>	
If so, explain:					
Comments:					

10. Authorization of Data Validation

Data Validator Name: _____ Signature: _____ Date: _____	Reviewed by: _____ _____
---	---

Stage 2A Data Validation Checklist for Dioxin Sample Analysis

Site:	Case No:	Laboratory:
Project:	Sample Matrix:	Analyses:
Sample Date(s):	Analysis Date(s):	
Data Validator:	Validation Date(s):	

1. Holding Times

Analyte	Laboratory	Matrix	Method	Holding Times	Collection Date(s):	Analysis Date(s)	Holding Time Met (Y/N)	Affected Data Flagged (Y/N)
Were any data flagged because of holding time?							Y <input type="checkbox"/>	N <input type="checkbox"/>
Were any data flagged because of preservation problems?							Y <input type="checkbox"/>	N <input type="checkbox"/>
Comments:								

2. Blanks

Were Method Blanks (MBs) analyzed at the frequency of 1 per analytical batch?	Y <input type="checkbox"/>	N <input type="checkbox"/>
Were MBs within the control window?	Y <input type="checkbox"/>	N <input type="checkbox"/>
Were any data flagged because of blank problems?	Y <input type="checkbox"/>	N <input type="checkbox"/>
Describe Any Actions Taken:		
Comments:		

3. Labeled Compounds

Were labeled compounds present in all extracted samples (including QC)?	Y <input type="checkbox"/>	N <input type="checkbox"/>
Were percent recoveries (%R) within the control window?	Y <input type="checkbox"/>	N <input type="checkbox"/>
Were any data flagged because of labeled compound problems?	Y <input type="checkbox"/>	N <input type="checkbox"/>
Describe Any Actions Taken:		
Comments:		

4. Laboratory Control Samples

Were Laboratory Control Samples (LCS) analyzed at the frequency of 1 per batch?	Y <input type="checkbox"/>	N <input type="checkbox"/>
Were LCS results within the control window?	Y <input type="checkbox"/>	N <input type="checkbox"/>
Were any data flagged because of LCS problems?	Y <input type="checkbox"/>	N <input type="checkbox"/>
Describe Any Actions Taken:		
Comments:		

5. Duplicate Sample Results

Were Laboratory Duplicate Samples (LDS) analyzed at the frequency of 1 per batch?	Y <input type="checkbox"/>	N <input type="checkbox"/>
Were LDS results within the control window?	Y <input type="checkbox"/>	N <input type="checkbox"/>
Were any data flagged because of LDS problems?	Y <input type="checkbox"/>	N <input type="checkbox"/>
Describe Any Actions Taken:		
Comments:		

6. Matrix Spike Sample Results

Were Laboratory Matrix Spike Samples (LMS) analyzed at the frequency of 1 per batch?	Y	<input type="checkbox"/>	N	<input type="checkbox"/>	N/A	<input type="checkbox"/>
Were LMS results within the control window?	Y	<input type="checkbox"/>	N	<input type="checkbox"/>	N/A	<input type="checkbox"/>
Were any data flagged because of LMS problems?	Y	<input type="checkbox"/>	N	<input type="checkbox"/>	N/A	<input type="checkbox"/>
Describe Any Actions Taken:						
Comments:						

7. Field Blanks

Were field blanks submitted as specified in the QAPP?	Y	<input type="checkbox"/>	N	<input type="checkbox"/>	N/A	<input type="checkbox"/>
Were field blanks within the control window?	Y	<input type="checkbox"/>	N	<input type="checkbox"/>	N/A	<input type="checkbox"/>
Were any data qualified because of field blank problems?	Y	<input type="checkbox"/>	N	<input type="checkbox"/>	N/A	<input type="checkbox"/>
Describe Any Actions Taken:						
Comments:						

8. Field Duplicates

Were field duplicates submitted as specified in the QAPP?	Y	<input type="checkbox"/>	N	<input type="checkbox"/>	N/A	<input type="checkbox"/>
Were results for field duplicates within the control window?	Y	<input type="checkbox"/>	N	<input type="checkbox"/>	N/A	<input type="checkbox"/>
Were any data qualified because of field duplicate problems?	Y	<input type="checkbox"/>	N	<input type="checkbox"/>	N/A	<input type="checkbox"/>
Describe Any Actions Taken:						
Comments:						

9. Overall Assessment

Are there analytical limitations of the data that users should be aware of?	Y	<input type="checkbox"/>	N	<input type="checkbox"/>
If so, explain: Overall Assessment				
Comments:				

10. Authorization of Data Validation

Data Validator Name: _____ Signature: _____ Date: _____	Reviewed by: _____ _____
---	---

Stage 2A Data Validation Checklist for Radon Sample Analysis

Site:	Case No:	Laboratory:
Project:	Sample Matrix:	Analyses:
Sample Date(s):	Analysis Date(s):	
Data Validator:	Validation Date(s):	

1. Holding Times

Analyte	Laboratory	Matrix	Method	Holding Times	Collection Date(s)	Analysis Date(s)	Holding Time Met (Y/N)	Affected Data Flagged (Y/N)
*Reference for Holding Times – BRW Phase II QAPP Were any data flagged because of holding time? Y <input type="checkbox"/> N <input type="checkbox"/> Were any data flagged because of preservation problems? Y <input type="checkbox"/> N <input type="checkbox"/> Describe Any Actions Taken: Comments:								

2. Blanks

Were Method Blanks (MBs) analyzed at the frequency of 1 per analytical batch?	Y <input type="checkbox"/>	N <input type="checkbox"/>
Were MBs within the control window?	Y <input type="checkbox"/>	N <input type="checkbox"/>
Were any data flagged because of blank problems?	Y <input type="checkbox"/>	N <input type="checkbox"/>
Describe Any Actions Taken:		
Comments:		

3. Quality Control Check Samples

Were Quality Control Check Samples (QCCS) analyzed at the frequency of 1 per batch?	Y <input type="checkbox"/>	N <input type="checkbox"/>
Were QCCS results within the control window?	Y <input type="checkbox"/>	N <input type="checkbox"/>
Were any data flagged because of QCCS problems?	Y <input type="checkbox"/>	N <input type="checkbox"/>
Describe Any Actions Taken:		
Comments:		

4. Duplicate Sample Results

Were Laboratory Duplicate Samples (LDS) analyzed at the frequency of 1 per 10 samples?	Y <input type="checkbox"/>	N <input type="checkbox"/>
Were LDS results within the control window?	Y <input type="checkbox"/>	N <input type="checkbox"/>
Were any data flagged because of LDS problems?	Y <input type="checkbox"/>	N <input type="checkbox"/>
Describe Any Actions Taken:		
Comments:		

5. Matrix Spike Sample Results

Were Laboratory Matrix Spike Samples (LMS) analyzed at the frequency of 1 per batch?	Y <input type="checkbox"/>	N <input type="checkbox"/>	N/A
Were LMS results within the control window?	Y <input type="checkbox"/>	N <input type="checkbox"/>	N/A
Were any data flagged because of LMS problems?	Y <input type="checkbox"/>	N <input type="checkbox"/>	
Describe Any Actions Taken:			
Comments:			

6. Field Blanks

Were field blanks submitted as specified in the QAPP?	Y	<input type="checkbox"/>	N	<input type="checkbox"/>	N/A	<input type="checkbox"/>
Were field blanks within the control window?	Y	<input type="checkbox"/>	N	<input type="checkbox"/>	N/A	<input type="checkbox"/>
Were any data qualified because of field blank problems?	Y	<input type="checkbox"/>	N	<input type="checkbox"/>	N/A	<input type="checkbox"/>
Describe Any Actions Taken:						
Comments:						

7. Field Duplicates

Were field duplicates submitted as specified in the QAPP?	Y	<input type="checkbox"/>	N	<input type="checkbox"/>	N/A	<input type="checkbox"/>
Were results for field duplicates within the control window?	Y	<input type="checkbox"/>	N	<input type="checkbox"/>	N/A	<input type="checkbox"/>
Were any data qualified because of field duplicate problems?	Y	<input type="checkbox"/>	N	<input type="checkbox"/>	N/A	<input type="checkbox"/>
Describe Any Actions Taken:						
Comments:						

8. Overall Assessment

Are there analytical limitations of the data that users should be aware of?	Y	<input type="checkbox"/>	N	<input type="checkbox"/>
If so, explain:				
Comments:				

9. Authorization of Data Validation

Data Validator Name: _____ Signature: _____ Date: _____	Reviewed by: _____ _____
---	---

Site:
Project:
Sample Date(s):
Data Validator:

Case No:
Sample Matrix:
Analysis Date(s):
Validation Date(s):

Laboratory:
Analyses:

1. Holding Times

Analyte	Laboratory	Matrix	Method	Holding Times	Collection Date(s)	Analysis Date(s)	Holding Time Met (Y/N)	Affected Data Flagged (Y/N)
<p>*Reference for Holding Times –</p> <p>Were any data flagged because of holding time? Y <input type="checkbox"/> N <input checked="" type="checkbox"/></p> <p>What sample preparation steps were performed (i.e. drying, sieving etc.)? Were the samples prepped according to the SAP/QAPP? Y <input checked="" type="checkbox"/> N <input type="checkbox"/></p> <p>Describe Any Actions Taken:</p> <p>Comments:</p>								

2. Energy Calibration (System Check)

Was the energy calibration performed at the frequency of once per day?	Y	<input type="checkbox"/>	N	<input checked="" type="checkbox"/>
Was the energy calibration Resolution below 195?	Y	<input type="checkbox"/>	N	<input type="checkbox"/>
Did the energy calibration run for at least 50 seconds?	Y	<input type="checkbox"/>	N	<input type="checkbox"/>
Describe Any Actions Taken:				
Comments:				

3. SiO₂ Standards

Was the SiO ₂ Standard analyzed at the beginning of analysis?	Y	<input type="checkbox"/>	N	<input type="checkbox"/>
Was the SiO ₂ Standard analyzed at the frequency of 1 per 20 natural samples?	Y	<input type="checkbox"/>	N	<input type="checkbox"/>
Were the SiO ₂ Standard results within the control limits?	Y	<input type="checkbox"/>	N	<input type="checkbox"/>
Were any data flagged because of the SiO ₂ Standard results?	Y	<input type="checkbox"/>	N	<input type="checkbox"/>
Describe Any Actions Taken:				
Comments:				

4. Calibration Check Samples

Were the appropriate Calibration Check Samples (CCS) analyzed at the beginning of analysis?	Y	<input type="checkbox"/>	N	<input type="checkbox"/>
Were the appropriate CCS analyzed at the frequency of 1 per 20 natural samples?	Y	<input type="checkbox"/>	N	<input type="checkbox"/>
Were CCS results within the control limits?	Y	<input type="checkbox"/>	N	<input type="checkbox"/>
Were any data flagged because of CCS problems?	Y	<input type="checkbox"/>	N	<input type="checkbox"/>
Describe Any Actions Taken:				
Comments:				

5. Duplicate Sample Results

Were Duplicate Samples analyzed at the frequency of 1 per 20 natural samples?	Y	<input type="checkbox"/>	N	<input type="checkbox"/>
Were Duplicate Sample results within the control window?	Y	<input type="checkbox"/>	N	<input type="checkbox"/>
Were any data flagged because of duplicate sample results?	Y	<input type="checkbox"/>	N	<input type="checkbox"/>
Describe Any Actions Taken:				
Comments:				

6. Replicate Sample Results

Were Replicate Samples analyzed at the frequency of 1 per 20 natural samples?	Y	<input type="checkbox"/>	N	<input type="checkbox"/>
Were replicate sample results within the control window?	Y	<input type="checkbox"/>	N	<input type="checkbox"/>
Were any data flagged because of replicate sample results?	Y	<input type="checkbox"/>	N	<input type="checkbox"/>
Describe Any Actions Taken:				
Comments:				

7. Overall Assessment

Are there analytical limitations of the data that users should be aware of?	Y	<input type="checkbox"/>	N	<input type="checkbox"/>
If so, explain:				
Comments:				

8. Authorization of Data Validation

Data Validator Name: _____ Signature: _____ Date: _____	Reviewed by: _____ _____
--	---

Level A/B Assessment Checklist

1. General Information

Site:
 Project:
 Client:
 Sample Matrix:

2. Screening Result

Data are:

- 1. Unusable _____
- 2. Level A _____
- 3. Level B _____

I. Level A

Criteria – The following must be fully documented.	Yes/No	Comments
1. Sampling date		
2. Sampling team or leader		
3. Physical description of sampling location		
4. Sample depth (soils)		
5. Sample collection technique		
6. Field preparation technique		
7. Sample preservation technique		
8. Sample shipping records		

II. Level B

Criteria – The following must be fully documented.	Yes/No	Comments
1. Field instrumentation methods and standardization complete		
2. Sample container preparation		
3. Collection of field replicates (1/20 minimum)		
4. Proper and decontaminated sampling equipment		
5. Field custody documentation		
6. Shipping custody documentation		
7. Traceable sample designation number		
8. Field notebook(s), custody records in secure repository		
9. Completed field forms		

Appendix E - Data Validation

Data Validation Quality Control Criteria

BRW Phase III Data Validation Quality Control Criteria - Field QC Samples

Field QC Samples

BRW Phase III Data Validation Quality Control Criteria - Pace

ICP-MS (EPA 200.8/EPA 6020)

ICP-AES (EPA 200.7/EPA 6010)

Mercury (EPA 245.1/EPA 7471B)

General Chemistry -pH (9045D); Specific Conductivity (ASA 10-3-3); Nitrogen, NO₂ plus NO₃ (EPA 353.2); Phosphorus (EPA 365.1); Percent Moisture (ASTM D2974); Anions (EPA 300.0); Sulfide (SM 4500-S2-D); Sulfide (SW-846 9030B); Total Solids (SM 2540G)

Volatile Petroleum Hydrocarbons (VPH) (MA VPH)

Polychlorinated biphenyl (PCB) (SW-846 8082A)

Extractable Petroleum Hydrocarbons (EPH) (MA EPH)

Pentachlorophenol (PCP) (SW-846 8270D SIM)

Dioxins (EPA 1613B)

BRW Phase III Data Validation Quality Control Criteria - MBMG

Radon (EPA 913.0 Modified)

BRW Phase III Data Validation Quality Control Criteria - Eurofins

ICP-MS (EPA 200.8/EPA 6020)

ICP-AES (EPA 200.7/EPA 6010)

Mercury (EPA 1631E/7471A)

General Chemistry -pH (9045D); Specific Conductivity (120.1); Nitrogen, NO₂ plus NO₃ (EPA 353.2); Phosphorus (EPA 365.1); Percent Moisture (ASTM D2216); Anions (EPA 300.0); Alkalinity (SM 2320B); Total Dissolved Solids (SM 2540C)

Polychlorinated biphenyl (PCB) (SW-846 8082A)

Dioxins (1613B)

Volatile Petroleum Hydrocarbons (VPH) (MT VPH)

Extractable Petroleum Hydrocarbons (EPH) (MT EPH)

1,2 - Dibromoethane (EDB) (SW-846 8011)

1,2-Dichloroethane (DCE) (SW-846 8260B)

Pentachlorophenol (PCP) (SW-846 8270D SIM)

BRW Phase III Data Validation Quality Control Criteria - XRF

XRF

Appendix E. BRW Phase III Data Validation Quality Control Criteria - Field Quality Control Samples

Field Quality Control Samples

Field Quality Control Samples							
Quality Control	Frequency	Acceptance Criteria	Criteria	Action			Reference
				Associated Sample Result Detect	Associated Sample Result Non-Detect	Reason Code	
Field Blank/ Equipment Rinsate Blank	One per 20 samples (samples collected with re-usable equipment only)	blank result ≤ 2x MDL	blank result ≤ 2x MDL	No Qualification	No Qualification	FB RB	BRW Phase III QAPP CFRSSI QAPP
			Positive blank result > 2x MDL	Results < 5x blank result U	No Qualification		
			Absolute value of negative blank result > 2x MDL	Results < 5x absolute value of negative blank result J	UJ		
Field Duplicate	One per 20 samples	1. If both original sample and duplicate sample results are ≥ 5x RL, then RPD ≤ 20% (water) or RPD ≤ 35% (soil) or RPD ≤ 50% (MA-EPH, 8270) 2. If original sample or duplicate sample result < 5x RL (including non-detects), then difference between sample and duplicate ≤ RL (water) or ≤ 2x RL (soils)	Both original sample and duplicate sample results are ≥ 5x RL and RPD ≤ 20% (water) or RPD ≤ 35% (soil)	No Qualification	No Qualification	FD	BRW Phase III QAPP NFG
			Both original sample and duplicate sample results are ≥ 5x RL and RPD > 20% (water) or RPD > 35% (soil)	J	UJ		
			If RPD > 100%.	Professional Judgement	Professional Judgement		
			Original sample or duplicate sample result is < 5x the RL and difference between the sample and duplicate ≤ RL (water) or ≤ 2x RL (soils)	No Qualification	No Qualification		
			Original sample or duplicate sample result is < 5x RL and difference between the sample and duplicate > RL (water) or > 2x RL (soils)	J	UJ		

Notes:

1. Associated sample results:

For Field Blank results that do not meet technical criteria, apply action to all samples in the SDG.

For Field Duplicate results that do not meet technical criteria, apply action to field duplicate pair and any samples from the same sample location in the SDG.

Qualifications:

- U - Non-detect
- UJ - Estimated non-detect
- J - Estimated
- R - Rejected

Abbreviations:

- MDL - method detection limit
- RL - reporting limit
- RPD - relative percent difference

References:

CFRSSI QAPP - ARCO, 1992. Clark Fork River Superfund Site Investigations (CFRSSI) Quality Assurance Project Plan (QAPP). Prepared for ARCO by PTI Environmental Services, Bellevue, Washington. May 1992.

NFG - EPA, 2020. National Functional Guidelines for Inorganic Superfund Methods Data Review. November 2020.

-- Available at EPA's Superfund Analytical Services and Contract Laboratory Program website: <https://www.epa.gov/clp/contract-laboratory-program-national-functional-guidelines-data-review>

Appendix E. BRW Phase III Data Validation Quality Control Criteria - Pace

ICP-MS (EPA 200.8/EPA 6020)

ICP-AES (EPA 200.7/EPA 6010)

Mercury (EPA 245.1/EPA 7471B)

General Chemistry -pH (9045D); Specific Conductivity (ASA 10-3-3); Nitrogen, NO₂ plus NO₃ (EPA 353.2); Phosphorus (EPA 365.1); Percent Moisture (ASTM D2974); Anions (EPA 300.0); Total Dissolved Solids (SM 2540C)

Volatile Petroleum Hydrocarbons (VPH) (MA VPH)

Polychlorinated biphenyl (PCB) (SW-846 8082A)

Extractable Petroleum Hydrocarbons (EPH) (MA EPH)

Pentachlorophenol (PCP) (SW-846 8270D SIM)

Dioxins (EPA 1613B)

ICP-MS (EPA 200.8 / EPA 6020) - Pace							
Quality Control	Frequency	Acceptance Criteria	Criteria	Action			Reference
				Associated Sample Result Detected	Associated Sample Result Non-Detected	Reason Code	
Holding Time	Every sample	≤180 Days	Hold Time > 180 Days	J-	Professional Judgement UJ or R	H	NFG
Preservation	Every sample	pH ≤ 2 (water)	Samples received with pH > 2 and pH not adjusted	Professional Judgement J-	Professional Judgement R	Pres	NFG
Method Blank (MB)	MB - Each analytical batch of samples for every 20 (or fewer) samples received	absolute value of blank result ≤ 2x MDL	blank result < 2x MDL	No Qualification	No Qualification	MB	CFRSSI QAPP
			Positive blank result > 2x MDL.	Results < 5x blank result U	No Qualification		
			absolute value of negative blank result > 2x MDL	Results < 5x absolute value of negative blank result J	UJ		
Laboratory Control Sample (LCS)	Each analytical batch of samples for every 20 (or fewer) samples received	%R 70-130%	%R < 40%	J-	R	L%	BRW Phase III QAPP NFG
			%R 40-69%	J-	UJ		
			%R 70-130%	No Qualification	No Qualification		
			%R 131-150%	J+	No Qualification		
			%R > 150%	R	No Qualification		
Laboratory Duplicate Samples (LDS)	Each analytical batch of samples for every 20 (or fewer) samples received	1. If both original sample and duplicate sample results are ≥ 5x RL, then RPD ≤ 20% (water) or RPD ≤ 35% (soils); 2. If original sample or duplicate sample result < 5x RL (including non-detects), then difference between sample and duplicate ≤ RL (water) or ≤ 2x RL (soils)	Both original and duplicate sample results ≥ 5x RL and RPD > 20% (water) or RPD > 35% (soils)	J	UJ	D%	BRW Phase III QAPP NFG
			Both original and duplicate sample results ≥ 5x RL and RPD ≤ 20% (water) or RPD ≤ 35% (soils)	No Qualification	No Qualification		
			RPD > 100%	Professional Judgement	Professional Judgement		
			Original sample or duplicate sample result is < 5x the RL and difference between the sample and duplicate > RL (water) or > 2x RL (soils)	J	UJ		
			Original sample or duplicate sample result is < 5x the RL and difference between the sample and duplicate ≤ RL or ≤ 2x RL (soils)	No Qualification	No Qualification		

ICP-MS (EPA 200.8 / EPA 6020) - Pace												
Quality Control	Frequency	Acceptance Criteria	Criteria	Action			Reference					
				Associated Sample Result Detected	Associated Sample Result Non-Detected	Reason Code						
Matrix Spike (MS)	Each analytical batch of samples for every 20 (or fewer) samples received	%R 75-125% If the original sample result is $\geq 4x$ the spike amount added, the data shall not be flagged even if the %R exceeds the acceptance criteria	Matrix Spike %R < 30% Post-digestion spike %R < 75%	J-	R	S%	BRW Phase III QAPP NFG					
			Matrix Spike %R < 30% Post-digestion spike %R $\geq 75\%$	J	UJ							
			Matrix Spike %R 30-74% Post-digestion Spike %R < 75%	J-	UJ							
			Matrix Spike %R 30-74% Post-digestion spike %R $\geq 75\%$	J	UJ							
			Matrix Spike %R > 125% Post-digestion spike %R > 125%	J+	No Qualification							
			Matrix Spike %R > 125% Post-digestion spike %R $\leq 125\%$	J	No Qualification							
			Matrix Spike %R < 30% No post-digestion spike performed	J-	R							
			Matrix Spike %R 30-74% No post-digestion spike performed	J-	UJ							
			Matrix Spike %R 75-125% No post-digestion spike is required	No Qualification	No Qualification							
			Matrix Spike %R > 125% No post-digestion spike performed	J+	No Qualification							
			Sample analyte concentration $\geq 4x$ spike concentration	No Qualification	No Qualification							
			Serial Dilution (SD)	Each analytical batch of samples.	%D $\leq 20\%$ if sample concentration is sufficiently high			Sample >50x MDL and SD \geq RL and %D > 20%	J	UJ	SD	NFG
								Sample >50x MDL and SD \geq RL and %D $\geq 100\%$	Professional Judgement	Professional Judgement		
Sample > 5x RL and SD < RL	No Qualification	No Qualification										
Interferences present	Professional Judgement	Professional Judgement										

ICP-AES (EPA 200.7 / EPA 6010D) - Pace							
Quality Control	Frequency	Acceptance Criteria	Criteria	Action			Reference
				Associated Sample Result Detected	Associated Sample Result Non-Detected	Reason Code	
Holding Time	Every sample	≤ 180 Days	Hold Time > 180 Days	J-	Professional Judgement UJ or R	H	NFG
Preservation	Every sample	pH ≤ 2 (water)	Samples received with pH > 2 and pH not adjusted	Professional Judgement J-	Professional Judgement R	Pres	NFG
Method Blank (MB)	MB - Each analytical batch of samples for every 20 (or fewer) samples received	absolute value of blank result ≤ 2x MDL	blank result < 2x MDL	No Qualification	No Qualification	MB	CFRSSI QAPP
			Positive blank result > 2x MDL.	Results < 5x blank result U	No Qualification		
			absolute value of negative blank result > 2x MDL	Results < 5x absolute value of negative blank result J	UJ		
Laboratory Control Sample (LCS)	Each analytical batch of samples for every 20 (or fewer) samples received	%R 70-130%	%R < 40%	J-	R	L%	BRW Phase III QAPP NFG
			%R 40-69%	J-	UJ		
			%R 70-130%	No Qualification	No Qualification		
			%R 131-150%	J+	No Qualification		
			%R > 150%	R	No Qualification		
Laboratory Duplicate Samples (LDS)	Each analytical batch of samples for every 20 (or fewer) samples received	1. If both original sample and duplicate sample results are ≥ 5x RL, then RPD ≤ 20% (water) or RPD ≤ 35% (soils); 2. If original sample or duplicate sample result < 5x RL (including non-detects), then difference between sample and duplicate ≤ RL (water) or ≤ 2x RL (soils)	Both original and duplicate sample results ≥ 5x RL and RPD > 20% (water) or RPD > 35% (soils)	J	UJ	D%	BRW Phase III QAPP NFG
			Both original and duplicate sample results ≥ 5x RL and RPD ≤ 20% (water) or RPD ≤ 35% (soils)	No Qualification	No Qualification		
			RPD > 100%	Professional Judgement	Professional Judgement		
			Original sample or duplicate sample result is < 5x the RL and difference between the sample and duplicate > RL (water) or > 2x RL (soils)	J	UJ		
			Original sample or duplicate sample result is < 5x the RL and difference between the sample and duplicate ≤ RL or ≤ 2x RL (soils)	No Qualification	No Qualification		

ICP-AES (EPA 200.7 / EPA 6010D) - Pace												
Quality Control	Frequency	Acceptance Criteria	Criteria	Action			Reference					
				Associated Sample Result Detected	Associated Sample Result Non-Detected	Reason Code						
Matrix Spike (MS)	Each analytical batch of samples for every 20 (or fewer) samples received	%R 75-125% If the original sample result is $\geq 4x$ the spike amount added, the data shall not be flagged even if the %R exceeds the acceptance criteria	Matrix Spike %R < 30% Post-digestion spike %R < 75%	J-	R	S%	BRW Phase III QAPP NFG					
			Matrix Spike %R < 30% Post-digestion spike %R $\geq 75\%$	J	UJ							
			Matrix Spike %R 30-74% Post-digestion Spike %R < 75%	J-	UJ							
			Matrix Spike %R 30-74% Post-digestion spike %R $\geq 75\%$	J	UJ							
			Matrix Spike %R > 125% Post-digestion spike %R > 125%	J+	No Qualification							
			Matrix Spike %R > 125% Post-digestion spike %R $\leq 125\%$	J	No Qualification							
			Matrix Spike %R < 30% No post-digestion spike performed	J-	R							
			Matrix Spike %R 30-74% No post-digestion spike performed	J-	UJ							
			Matrix Spike %R 75-125% No post-digestion spike is required	No Qualification	No Qualification							
			Matrix Spike %R > 125% No post-digestion spike performed	J+	No Qualification							
			Sample analyte concentration $\geq 4x$ spike concentration	No Qualification	No Qualification							
			Serial Dilution (SD)	Each analytical batch of samples	%D $\leq 20\%$ if sample concentration is sufficiently high			Sample >50x MDL and SD $\geq RL$ and %D > 20%	J	UJ	SD	NFG
								Sample >50x MDL and SD $\geq RL$ and %D $\geq 100\%$	Professional Judgement	Professional Judgement		
Sample > 5x RL and SD < RL	No Qualification	No Qualification										
Interferences present	Professional Judgement	Professional Judgement										

Mercury (EPA 245.1 and EPA 7471B) - Pace							
Quality Control	Frequency	Acceptance Criteria	Criteria	Action			Reference
				Associated Sample Result Detected	Associated Sample Result Non-Detected	Reason Code	
Holding Time	Every sample	28 Days	Hold Time > 28 Days	Professional Judgement J-	Professional Judgement UJ or R	H	NFG
Preservation	Every sample	pH ≤ 2 (water) ≤ 6°C (soil)	Samples received pH > 2 and pH not adjusted (water)	Professional Judgement J-	Professional Judgement UJ or R	Pres	NFG
			Samples received > 6°C but ≤ 10°C (soil)	Professional Judgement J-	Professional Judgement UJ or R		
			Samples received > 10°C (soil)	Professional Judgement J-	Professional Judgement UJ or R		
Method Blank (MB)	Each analytical batch of samples for every 20 (or fewer) samples received	absolute value of blank result ≤ 2x MDL	Non-detect or ≤ 2x the MDL	No Qualification	No Qualification	MB	CFRSSI QAPP
			Positive blank result > 2x MDL	Results < 5x blank result U	No Qualification		
			absolute value of negative blank result > 2x MDL	Result < 5x absolute value of negative blank result J	UJ		
Laboratory Control Sample (LCS)	Each analytical batch of samples for every 20 (or fewer) samples received	%R 80-120%	%R < 40%	J-	R	L%	BRW Phase III QAPP CFRSSI QAPP
			%R 40-79%	J-	UJ		
			%R 80-120%	No Qualification	No Qualification		
			%R > 120%	J+	No Qualification		
			%R > 150%	R	No Qualification		
Laboratory Duplicate Samples (LDS)	Each analytical batch of samples for every 20 (or fewer) samples received	1. If both original sample and duplicate sample results are ≥ 5x RL, then RPD ≤ 20% (water) or RPD ≤ 35% (soils); 2. If original sample or duplicate sample result is < 5x RL (including non-detects), then difference between sample and duplicate ≤ RL (water) or ≤ 2x RL (soils)	Both original and duplicate sample results ≥ 5x RL and RPD > 20% (water) or RPD > 35% (soils)	J	UJ	D%	BRW Phase III QAPP NFG
			Both original and duplicate sample results ≥ 5x RL and RPD ≤ 20% (water) or RPD ≤ 35% (soils)	No Qualification	No Qualification		
			RPD > 100%	Professional Judgement	Professional Judgement		
			Original sample or duplicate sample result is < 5x the RL and difference between the sample and duplicate > RL (water) or > 2x RL (soils)	J	UJ		
			Original sample or duplicate sample result is < 5x the RL and difference between the sample and duplicate ≤ RL or ≤ 2x RL (soils)	No Qualification	No Qualification		
Matrix Spike (MS)	Each analytical batch of samples for every 20 (or fewer) samples received	%R 75-125% If the original sample result is ≥ 4x the spike amount added, the data shall not be flagged even if the %R exceeds the acceptance criteria	Matrix Spike %R < 30%	J-	R	S%	BRW Phase III QAPP NFG
			Matrix Spike %R 30-74%	J-	UJ		
			Matrix Spike %R 75-125%	No Qualification	No Qualification		
			Matrix Spike %R > 125%	J+	No Qualification		
			Sample analyte concentration ≥ 4x spike concentration	No Qualification	No Qualification		

General Chemistry - Pace							
Quality Control	Frequency	Acceptance Criteria	Criteria	Action			Reference
				Associated Sample Result Detected	Associated Sample Result Non-Detected	Reason Code	
pH (9045D)							
Holding Time	Every sample	≤ 15 minutes	Hold Time > 15 minutes	J	N/A	H	BRW Phase III QAPP
Preservation	Every sample	≤ 6°C	Samples received > 6°C	Professional Judgement J	N/A	Pres	BRW Phase III QAPP NFG
Laboratory Control Sample (LCS)	Each analytical batch of samples for every 20 (or fewer) samples received	Results within ± 0.1 SU of true value	LCS result > ± 0.1 SU of true value	J	N/A	L%	CFRSSI QAPP
Laboratory Duplicate Samples (LDS)	Each analytical batch of samples for every 20 (or fewer) samples received	RPD ≤ 20% (water) or RPD ≤ 35% (soils)	RPD > 20% (water) or RPD > 35% (soils).	J	UJ	D%	CFRSSI QAPP BRW Phase III QAPP
Specific Conductivity (ASA 10-3.3)							
Holding Time	Every sample	≤ 28 days	Hold Time > 28 days	J	UJ	H	BRW Phase III QAPP
Preservation	Every sample	≤ 6°C	Samples received > 6°C	Professional Judgement J	Professional Judgement UJ	Pres	BRW Phase III QAPP NFG
Method Blank (MB)	MB - Each analytical batch of samples for every 20 (or fewer) samples received.	blank result ≤ 2x MDL	blank result > 2x MDL	Results < 5x the absolute value of the blank detection U	No Qualification	MB	CFRSSI QAPP
Laboratory Control Sample (LCS)	Each analytical batch of samples for every 20 (or fewer) samples received	%R 80-120%	%R < 80%	J-	UJ	L%	CFRSSI QAPP
			%R > 120%	J+	No Qualification		
Laboratory Duplicate Samples (LDS)	Each analytical batch of samples for every 20 (or fewer) samples received	1. If both original sample and duplicate sample results are ≥ 5x RL, then RPD ≤ 20% (water) or RPD ≤ 35% (soils); 2. If original sample or duplicate sample result < 5x RL (including non-detects), then difference between sample and duplicate ≤ RL (water) or ≤ 2x RL (soils)	Both original and duplicate sample results ≥ 5x RL and RPD > 20% (water) or RPD > 35% (soils)	J	UJ	D%	BRW Phase III QAPP CFRSSI QAPP
			Both original and duplicate sample results ≥ 5x RL and RPD ≤ 20% (water) or RPD ≤ 35% (soils)	No Qualification	No Qualification		
			RPD > 100%	Professional Judgement	Professional Judgement		
			Original sample or duplicate sample result is < 5x the RL and difference between the sample and duplicate > RL (water) or > 2x RL (soils)	J	UJ		
			Original sample or duplicate sample result is < 5x the RL and difference between the sample and duplicate ≤ RL or ≤ 2x RL (soils)	No Qualification	No Qualification		

General Chemistry - Pace							
Quality Control	Frequency	Acceptance Criteria	Criteria	Action			Reference
				Associated Sample Result Detected	Associated Sample Result Non-Detected	Reason Code	
Nitrogen, NO2 plus NO3 (EPA 353.2)							
Holding Time	Every sample	≤ 28 days	Hold Time > 28 days	J	UJ	H	BRW Phase III QAPP
Preservation	Every Sample	H ₂ SO ₄ to pH < 2 ≤ 6°C	Sample received with pH > 2 and pH not adjusted Samples received outside > 6°C	Professional Judgement J-	Professional Judgement R	Pres	BRW Phase III QAPP
Method Blank (MB)	MB - Each analytical batch of samples for every 20 (or fewer) samples received.	Absolute value of blank result ≤ 2x MDL	Absolute value of blank result > 2x MDL	Results < 5x the absolute value of the blank detection U	No Qualification	MB	CFRSSI QAPP
Laboratory Control Sample (LCS)	Each analytical batch of samples for every 20 (or fewer) samples received	%R 80-120%	%R < 80%	J-	UJ	L%	BRW Phase III QAPP CFRSSI QAPP
			%R > 120%	J+	No Qualification		
Laboratory Duplicate Samples (LDS)	Each analytical batch of samples for every 20 (or fewer) samples received	1. If both original sample and duplicate sample results are ≥ 5x RL, then RPD ≤ 20% (water); 2. If original sample or duplicate sample result < 5x RL (including non-detects), then difference between sample and duplicate ≤ RL (water)	Both original and duplicate sample results ≥ 5x RL and RPD > 20% (water)	J	UJ	D%	BRW Phase III QAPP CFRSSI QAPP
			Both original and duplicate sample results ≥ 5x RL and RPD ≤ 20% (water)	No Qualification	No Qualification		
			RPD > 100%	Professional Judgement	Professional Judgement		
			Original sample or duplicate sample result is < 5x the RL and difference between the sample and duplicate > RL (water)	J	UJ		
			Original sample or duplicate sample result is < 5x the RL and difference between the sample and duplicate ≤ RL (water)	No Qualification	No Qualification		
Matrix Spike (MS)	Each analytical batch of samples for every 20 (or fewer) samples received	%R 80-120% If the original sample result is ≥ 4x the spike amount added, the data shall not be flagged even if the %R exceeds the acceptance criteria	%R < 80%	J-	UJ	S%	CFRSSI QAPP
			%R 80-120%	No Qualification	No Qualification		
			%R > 120%	J+	No Qualification		
			Sample analyte concentration > 4x spike concentration	No Qualification	No Qualification		

General Chemistry - Pace							
Quality Control	Frequency	Acceptance Criteria	Criteria	Action			Reference
				Associated Sample Result Detected	Associated Sample Result Non-Detected	Reason Code	
Phosphorus (EPA 365.1)							
Holding Time	Every sample	≤ 28 days	Hold Time > 28 days	J	UJ	H	BRW Phase III QAPP
Preservation	Every Sample	H ₂ SO ₄ to pH < 2 ≤ 6°C	Sample received with pH > 2 and pH not adjusted Samples received outside > 6°C	Professional Judgement J-	Professional Judgement R	Pres	BRW Phase III QAPP
Method Blank (MB)	MB - Each analytical batch of samples for every 20 (or fewer) samples received.	Absolute value of blank result ≤ 2x MDL	Absolute value of blank result > 2x MDL	Results < 5x the absolute value of the blank detection U	No Qualification	MB	CFRSSI QAPP
Laboratory Control Sample (LCS)	Each analytical batch of samples for every 20 (or fewer) samples received	%R 80-120%	%R < 80%	J-	UJ	L%	BRW Phase III QAPP CFRSSI QAPP
			%R > 120%	J+	No Qualification		
Laboratory Duplicate Samples (LDS)	Each analytical batch of samples for every 20 (or fewer) samples received	1. If both original sample and duplicate sample results are ≥ 5x RL, then RPD ≤ 20% (water) ; 2. If original sample or duplicate sample result < 5x RL (including non-detects), then difference between sample and duplicate ≤ RL (water)	Both original and duplicate sample results ≥ 5x RL and RPD > 20% (water)	J	UJ	D%	BRW Phase III QAPP CFRSSI QAPP
			Both original and duplicate sample results ≥ 5x RL and RPD ≤ 20% (water)	No Qualification	No Qualification		
			RPD > 100%	Professional Judgement	Professional Judgement		
			Original sample or duplicate sample result is < 5x the RL and difference between the sample and duplicate > RL (water)	J	UJ		
			Original sample or duplicate sample result is < 5x the RL and difference between the sample and duplicate ≤ RL (water)	No Qualification	No Qualification		
Matrix Spike (MS)	Each analytical batch of samples for every 20 (or fewer) samples received	%R 80-120% If the original sample result is ≥ 4x the spike amount added, the data shall not be flagged even if the %R exceeds the acceptance criteria	%R < 80%	J-	UJ	S%	CFRSSI QAPP
			%R 80-120%	No Qualification	No Qualification		
			%R > 120%	J+	No Qualification		
			Sample analyte concentration > 4x spike concentration	No Qualification	No Qualification		
Percent Moisture (ASTM D2974 / SW-846 3550C)							
Laboratory Duplicate Sample (LDS)	Each analytical batch of samples for every 20 (or fewer) samples received	RPD ≤ 35%	RPD > 35%	J	UJ	D%	CFRSSI QAPP BRW Phase III QAPP

General Chemistry - Pace							
Quality Control	Frequency	Acceptance Criteria	Criteria	Action			Reference
				Associated Sample Result Detected	Associated Sample Result Non-Detected	Reason Code	
Anions (EPA 300.0)							
Holding Time	Every sample	≤ 28 days	Hold Time > 28 days	J	UJ	H	BRW Phase III QAPP
Preservation	Every sample	≤ 6°C	Samples received > 6°C	Professional Judgement J	Professional Judgement UJ	Pres	BRW Phase III QAPP NFG
Method Blank (MB)	MB - 1 per batch or 1 per 20 samples.	Absolute value of blank result ≤ 2x MDL	Absolute value of blank result > 2x MDL	Results < 5x the absolute value of the blank detection U	No Qualification	MB	CFRSSI QAPP
Laboratory Control Sample (LCS)	1 per batch or 1 per 20 samples.	%R 80-120%	%R < 80%	J-	UJ	LCS	BRW Phase III QAPP NFG
			%R > 120%	J+	No Qualification		
Laboratory Duplicate Samples (LDS)	Each analytical batch of samples for every 20 (or fewer) samples received	1. If both original sample and duplicate sample results are ≥ 5x RL, then RPD ≤ 20% (water) ; 2. If original sample or duplicate sample result < 5x RL (including non-detects), then difference between sample and duplicate ≤ RL (water)	Both original and duplicate sample results ≥ 5x RL and RPD > 20% (water)	J	UJ	D%	BRW Phase III QAPP NFG
			Both original and duplicate sample results ≥ 5x RL and RPD ≤ 20% (water)	No Qualification	No Qualification		
			RPD > 100%	Professional Judgement	Professional Judgement		
			Original sample or duplicate sample result is < 5x the RL and difference between the sample and duplicate > RL (water)	J	UJ		
			Original sample or duplicate sample result is < 5x the RL and difference between the sample and duplicate ≤ RL (water)	No Qualification	No Qualification		
Matrix Spike (MS)	1 per batch or 1 per 20 samples.	%R 80-120% If sample analyte concentration < 4x spike concentration	%R < 30%	J-	R	S%	BRW Phase III QAPP NFG
			%R 30-79%	J	UJ		
			%R 80-120%	No Qualification	No Qualification		
			%R > 120%	J+	No Qualification		
			Sample analyte concentration > 4x spike concentration	No Qualification	No Qualification		

General Chemistry - Pace							
Quality Control	Frequency	Acceptance Criteria	Criteria	Action			Reference
				Associated Sample Result Detected	Associated Sample Result Non-Detected	Reason Code	
Total Dissolved Solids (SM 2540C)							
Holding Time	Every sample	≤ 7 days	Hold Time > 7 days	J	UJ	H	BRW Phase III QAPP
Preservation	Every sample	≤ 6°C	Samples received > 6°C	Professional Judgement J	Professional Judgement UJ	Pres	BRW Phase III QAPP
Method Blank (MB)	MB - 1 per batch or 1 per 20 samples.	Absolute value of blank result ≤ 2x MDL	Absolute value of blank result > 2x MDL	Results < 5x the absolute value of the blank detection U	No Qualification	MB	CFRSSI QAPP
Laboratory Control Sample (LCS)	1 per batch or 1 per 20 samples.	%R 80-120%	%R < 80%	J-	UJ	LCS	CFRSSI QAPP BRW Phase III QAPP
			%R > 120%	J+	No Qualification		
Laboratory Duplicate Samples (LDS)	Each analytical batch of samples for every 20 (or fewer) samples received	1. If both original sample and duplicate sample results are ≥ 5x RL, then RPD ≤ 20%; 2. If original sample or duplicate sample result < 5x RL (including non-detects), then difference between sample and duplicate ≤ RL	Both original and duplicate sample results ≥ 5x RL and RPD > 20%	J	UJ	D%	BRW Phase III QAPP CFRSSI QAPP
			Both original and duplicate sample results ≥ 5x RL and RPD ≤ 20%	No Qualification	No Qualification		
			RPD > 100%	Professional Judgement	Professional Judgement		
			Original sample or duplicate sample result is < 5x the RL and difference between the sample and duplicate > RL	J	UJ		
			Original sample or duplicate sample result is < 5x the RL and difference between the sample and duplicate ≤ RL	No Qualification	No Qualification		

Volatile Petroleum Hydrocarbons (MA VPH) - Pace							
Quality Control	Frequency	Acceptance Criteria	Criteria	Action			Reference
				Associated Sample Result Detected	Associated Sample Result Non-Detected	Reason Code	
Holding Time	Every sample	Soil ≤ 7 days collection - extraction	Collection to extraction > 7 days	J	UJ	H	BRW Phase III QAPP Method VPH
		Soil ≤ 28 days extraction - analysis	Extraction to analysis > 28 days	J	UJ		
		Water ≤ 14 days collection - analysis	Collection to analysis > 14 days	J	UJ		
Preservation	Every sample	Soil ≤ 6°C	Samples received > 6°C	Professional Judgement J-	Professional Judgement R	Pres	BRW Phase III QAPP Method VPH
		Water ≤ 6°C; HCl	Samples received pH > 2 and pH not adjusted (water) Samples received > 6°C	Professional Judgement J-	Professional Judgement R		
Method Blank (MB)	Before samples and at least 1 MB every 24 hours	blank result ≤ 2x MDL	blank result > 2x MDL	Results < 5x blank result U	No Qualification	MB	CFRSSI QAPP
Trip Blank	1 per shipment	≤ 2x MDL for target analytes, not required to be analyzed if all associated results are ND	blank result > 2x MDL	Results < 5x blank result U	No Qualification	TB	CFRSSI QAPP
Surrogates	Present in all extracted samples (including QC)	%R 70-130% except CCV (80-120%)	%R < 70%	J-	UJ	Sur	Pace SOP
			%R 70-130%	No Qualification	No Qualification		
			%R > 130%	J+	No Qualification		
Laboratory Control Sample (LCS) and LCS Duplicate (LCSD)	Minimum 1/20 samples	%R 70-130% except nonane (30-130%)	%R < 70%	J-	UJ	L%	Pace SOP
			%R 70-130%	No Qualification	No Qualification		
			%R > 130%	J+	No Qualification		
		≤ 25% RPD	> 25% RPD	J	UJ	D%	
Matrix Spike/ Matrix Spike Duplicate (MS/MSD)	Each batch of 20 samples/matrix	%R 70-130% except nonane (30-130%)	%R < 70%	J-	UJ	S%	Pace SOP
			%R 70-130%	No Qualification	No Qualification		
			%R > 130%	J+	No Qualification		
		≤ 50% RPD	> 50% RPD	J	UJ	D%	

Polychlorinated biphenyl (PCB) (SW-846 8082A) - Pace							
Quality Control	Frequency	Acceptance Criteria	Criteria	Action			Reference
				Associated Sample Result Detected	Associated Sample Result Non-Detected	Reason Code	
Holding Time	Every sample	Aqueous Samples properly preserved: ≤ 1 year (for extraction) and ≤ 40 days (for analysis)	Aqueous samples not properly preserved: ≤ 1 year (for extraction) and ≤ 40 days (for analysis)	Use professional judgment	Use professional judgment	H	BRW Phase III QAPP NFG Pace SOP
			Aqueous samples not properly preserved: > 1 year (for extraction) and/or > 40 days (for analysis)	J	Use professional judgment		
			Aqueous samples properly preserved: ≤ 1 year (for extraction) and ≤ 40 days (for analysis)	No qualification	No qualification		
			Aqueous samples properly preserved: > 1 year (for extraction) and/or > 40 days (for analysis)	J	U		
			Holding time grossly exceeded	J	Use professional judgment UJ or R		
Preservation	Every sample	≤ 6 °C	Samples received outside >6°C	See Holding Time	See Holding Time	Pres	NFG
Method Blank (MB)	1 per preparation batch	blank result ≤ 2x MDL	blank result > 2x MDL	Results < 5x blank result U	No Qualification	MB	CFRSSI QAPP
Surrogates	Present in all samples (including QC)	Use Laboratory Statistical Control Limits (%R)	%R < Low Control Limit%	J-	UJ	Sur	Pace SOP
			%R > High Control Limit%	J+	No Qualification		
Laboratory Control Sample (LCS)	Minimum 1/20 samples	Use Laboratory Statistical Control Limits (%R)	%R < Low Control Limit%	J-	UJ	L%	Pace SOP
			%R > High Control Limit%	J+	No Qualification		
Matrix Spike/ Matrix Spike Duplicate (MS/MSD)	1/20 samples	Use Laboratory Statistical Control Limits (%R)	%R < Low Control Limit%	J-	UJ	S%	Pace SOP
			%R > High Control Limit%	J+	No Qualification		
Laboratory Duplicate Samples (LDS)	1/20 samples	Use Laboratory Statistical Control Limit (RPD)	RPD > Laboratory Statistical Control Limit	J	UJ	D%	Pace SOP

Extractable Petroleum Hydrocarbons (MA EPH) - Pace							
Quality Control	Frequency	Acceptance Criteria	Criteria	Action			Reference
				Associated Sample Result Detected	Associated Sample Result Non-Detected	Reason Code	
Holding Time	Every sample	Soils ≤ 7 days collection - extraction	Collection to extraction > 7 days	J	UJ	H	BRW Phase III QAPP EPH Montana Method
		Aqueous ≤ 14 days collection - extraction	Collection to extraction > 14 days	J	UJ		
		Soils and Aqueous ≤ 40 days extraction - analysis	Extraction to analysis > 40 days	J	UJ		
Preservation	Every sample	Soil ≤ 6°C	Samples received >6 °C	Professional Judgement J-	Professional Judgement R	Pres	EPH Montana Method Pace SOP
		Water ≤ 6°C; HCl	Samples received pH > 2 and pH not adjusted (water) Samples received >6°C	Professional Judgement J-	Professional Judgement R		
Method Blank (MB)	One per analytical batch	blank result ≤ 2x MDL	blank result > 2x MDL	Results < 5x blank result U	No Qualification	MB	CFRSSI QAPP
Surrogates	Present in all extracted samples (including QC)	%R 40-140%	%R < 40%	J-	UJ	Sur	Pace SOP
			%R 40-140%	No Qualification	No Qualification		
			%R > 140%	J+	No Qualification		
Laboratory Control Sample (LCS) and LCS Duplicate Sample	One pair per analytical batch (20 samples)	%R 40-140%	%R < 40%	J-	UJ	L%	Pace SOP
			%R 40-140%	No Qualification	No Qualification		
			%R > 140%	J+	No Qualification		
		≤ 25% RPD	RPD > 25%	J	UJ	D%	
Matrix Spike/ Matrix Spike Duplicate (MS/MSD)	One per work group	%R 40-140%	%R < 40%	J-	UJ	S%	Pace SOP
			%R < 60% (TEH) %R < 30% (n-nonane)				
			%R 40-140% %R 60-140% (TEH) %R 30-140% (n-nonane)				
		%R > 140%	J+	No Qualification			
		≤ 25% RPD	> 25% RPD	J	UJ	D%	Pace SOP

Pentachlorophenol (PCP) (SW-846 8270D SIM) - Pace							
Quality Control	Frequency	Acceptance Criteria	Criteria	Action			Reference
				Associated Sample Result Detected	Associated Sample Result Non-Detected	Reason Code	
Holding Time	Every sample	Aqueous ≤ 7 days, collection to extraction Aqueous ≤ 40 days, extraction to analysis	Aqueous samples not properly preserved: ≤ 7 days (for extraction) and ≤ 40 days (for analysis)	Use professional judgment None or J-	Use professional judgment None, UJ, or R	H	BRW Phase III QAPP NFG Pace SOP
			Aqueous samples not properly preserved: > 7 days (for extraction) and/or > 40 days (for analysis)	J	Use professional judgment UJ or R		
			Aqueous sample properly preserved and ≤ 7 days, collection to extraction and ≤ 40 days, extraction to analysis	No Qualification	No Qualification		
		Soils ≤ 14 days, collection to extraction Soils ≤ 40 days, extraction to analysis	Soil samples not properly preserved: ≤ 14 days (for extraction) and ≤ 40 days (for analysis)	Use professional judgment None or J-	Use professional judgment None, UJ or R		
			Soil samples not properly preserved: > 7 days (for extraction) and/or > 40 days (for analysis)	J	Use professional judgment UJ or R		
			Soil and sediment sample properly preserved and ≤ 14 days, collection to extraction and ≤ 40 days, extraction to analysis	No Qualification	No Qualification		
Aqueous and soils/sediment	Holding time grossly exceeded	J-	Use professional judgment UJ or R				
Preservation	Every sample	≤ 6 °C	Samples received outside >6°C	See Holding Time	See Holding Time	Pres	NFG
Method Blank (MB)	1 per batch of 20 samples or fewer	blank result ≤ 2x MDL	blank result > 2x MDL	Results < 10x blank result U	No Qualification	MB	CFRSSI QAPP
Surrogates	Present in all samples (including QC)	Use Laboratory Statistical Control Limits (%R)	%R < Low Control Limit%	J-	UJ	Sur	NFG Pace SOP
			%R > High Control Limit%	J+	No Qualification		
Laboratory Control Sample/Laboratory Control Sample Duplicate (LCS/LCSD)	1 per batch of 20 samples or fewer	Use Laboratory Statistical Control Limits (%R)	%R < Low Control Limit%	J-	UJ	L%	NFG Pace SOP
			%R > High Control Limit%	J+	No Qualification		
Matrix Spike/ Matrix Spike Duplicate (MS/MSD)	1 per batch of 20 samples if volume allows.	MS/MSD analyzed specified frequency (1 per 20 samples)	MS/MSD not analyzed at specified frequency	Use professional judgment	Use professional judgment	S%	BRW Phase III QAPP NFG Pace SOP
		Use Laboratory Statistical Control Limits (%R)	%R < Low Control Limit%	J	UJ (%R ≥ 10%) or R (%R < 10%)		
			%R > High Control Limit%	J	No Qualification		
Laboratory Duplicate Samples (LDS)	1/20 samples	Use Laboratory Statistical Control Limit (RPD)	RPD > Laboratory Statistical Control Limit	J	UJ	D%	NFG Pace SOP

Dioxins (EPA 1613B) - Pace							
Quality Control	Frequency	Acceptance Criteria	Criteria	Action			Reference
				Associated Sample Result Detected	Associated Sample Result Non-Detected	Reason Code	
Holding Time	Every sample	≤ 1 year collection - extraction	Collection to extraction > 1 year	Professional Judgement J-	Professional Judgement UJ or R	H	BRW Phase III QAPP NFG
Preservation	Every sample	≤ 6°C	Samples received > 6°C	Professional Judgement J	Professional Judgement UJ	Pres	NFG
Labeled Compounds	Present in all extracted samples (including QC)	Use Laboratory Statistical Control Limits (%R)	%R < Low Control Limit%	J-	UJ	LC	NFG Pace SOP
			%R > High Control Limit%	J+	No Qualification		
Method Blank (MB)	Each batch of 20 samples/matrix	blank result ≤ 1/2 RL	blank result > 1/2 RL	Results < 5x blank result U	No Qualification	MB	NFG
Laboratory Control Sample (LCS)	Each batch of 20 samples/matrix	Use Laboratory Statistical Control Limits (%R)	%R < Low Control Limit%	J-	UJ	L%	NFG Pace SOP
			%R > High Control Limit%	J+	No Qualification		
Matrix Spike/ Matrix Spike Duplicate (MS/MSD)	Each batch of 20 samples/matrix (if sample volume allows)	Use Laboratory Statistical Control Limits (%R)	%R < Low Control Limit%	J-	UJ	S%	NFG Pace SOP
			%R > High Control Limit%	J+	No Qualification		
Laboratory Duplicate Samples (LDS)	Each batch of 20 samples/matrix	≤ 30% RPD	> 30% RPD	J	UJ	D%	NFG

Notes:

1. Associated sample results:

For MB and LCS results that do not meet technical criteria, apply action to all samples in the analytical batch.

For LDS, LMS/MSD, and SD results that do not meet technical criteria, apply action to the parent sample and, per the NFG, "apply the action to all samples of the same matrix if the samples are considered sufficiently similar."

For holding time and preservation results that do not meet technical criteria, apply action to sample.

For Dioxins Labeled Compounds, if 2,3,7,8-TCDD-37Cl4 is outside laboratory control limits, apply action to all target compounds in that sample. For all other Labeled Compounds outside laboratory control limits, apply action only to the associated target compound in that sample.

2. For consistency in validations between validators, if a sample result is reported as non-detect, the MDL is used for the duplicate absolute difference calculations.

3. An LCS, an LMS, or an original sample may all be used to perform a laboratory duplicate. If a LCS Duplicate or LMS Duplicate is used, the QC sample must also meet the applicable %R technical criteria.

Qualifications:

Abbreviations:

U - Non-detect	J - Estimated	J+ - Estimated high	MDL - method detection limit	%D - percent difference	RPD - relative percent difference
UJ - Estimated non-detect	R - Rejected	J- - Estimated low	RL - reporting limit	%R - percent recovery	su - standard units

References:

CFRSSI QAPP - ARCO, 1992. Clark Fork River Superfund Site Investigations (CFRSSI) Quality Assurance Project Plan (QAPP). Prepared for ARCO by PTI Environmental Services, Bellevue, Washington. May 1992.

NFG - EPA, 2020. National Functional Guidelines for Inorganic Superfund Methods Data Review. November 2020.

-- Available at EPA's Superfund Analytical Services and Contract Laboratory Program website: <https://www.epa.gov/clp/contract-laboratory-program-national-functional-guidelines-data-review>

Pace SOP -

EPA 1613B -	ENV-SOP-MIN4-0026: Preparation and Analysis of Samples for the Determination of Dioxins and Furans by USEPA Method 8290/1613
SW-846 8082A -	ENV-SOP-MIN4-0013: Analysis of PCBs in Oil, Soil, Water, Wipe, and Air Matrices by SW8082 and 8082A
SW-846 8270D SIM -	ENV-SOP-MIN4-0063: GC-MS Analysis of PAH's by 8270 SIM
MA VPH -	ENV-SOP-MTJL-0091: Method for the Determination of Volatile Petroleum Hydrocarbons (VPH) (Based on MA VPH for NC, LA, CT, MT, and KS)
MA EPH -	ENV-SOP-MTJL-0090: Method for the Determination of Extractable Petroleum Hydrocarbons (EPH) (Based on MA EPH for NC, LA, MT, CT, NJ, and WA)

Appendix E. BRW Phase III Data Validation Quality Control Criteria - MBMG
Radon (EPA 913.0 Modified)

Radon (EPA 913.0 Modified) - MBMG							
Quality Control	Frequency	Acceptance Criteria	Criteria	Action			Reference
				Associated Sample Result Detect	Associated Sample Result Non-Detect	Reason Code	
Anions (EPA 300.0)							
Holding Time	Every sample	≤ 48 hours	Hold Time > 48 hours	J	UJ	H	BRW Phase III QAPP
Quality Control Check Samples (CCCS)	Every 10 samples	%R 80-120%	%R < 80%	J-	UJ	CS	CFRSSI QAPP
			%R > 120%	J+	No Qualification		
Laboratory Blanks	Each analytical batch of samples for every 20 (or fewer) samples received	Absolute value of the blank result ≤ 2x MDL	Absolute value of the blank result > 2x MDL	Results < 5x the absolute value of the blank detection U	No Qualification	MB	CFRSSI QAPP
Laboratory Duplicate Samples (LDS)	Each analytical batch of samples for every 20 (or fewer) samples received	1. If both original sample and duplicate sample results are ≥ 5x RL, then RPD ≤ 20%; 2. If original sample or duplicate sample result < 5x RL (including non-detects), then difference between sample and duplicate ≤ RL	Both original and duplicate sample results ≥ 5x RL and RPD > 20%	J	UJ	D%	BRW Phase III QAPP CFRSSI QAPP
			Both original and duplicate sample results ≥ 5x RL and RPD ≤ 20%	No Qualification	No Qualification		
			RPD > 100%	Professional Judgement	Professional Judgement		
			Original sample or duplicate sample result is < 5x the RL and difference between the sample and duplicate > RL	J	UJ		
			Original sample or duplicate sample result is < 5x the RL and difference between the sample and duplicate ≤ RL	No Qualification	No Qualification		

Notes:

1. Associated sample results:

For Laboratory Blank and CCCS results that do not meet technical criteria, apply action to all samples in the analytical batch.

For LDS, LMS/MSD, and SD results that do not meet technical criteria, apply action to the parent sample and, per the NFG, "apply the action to all samples of the same matrix if the samples are considered sufficiently similar."

For holding time and preservation results that do not meet technical criteria, apply action to sample.

2. For consistency in validations between validators, if a sample result is reported as non-detect, the MDL is used for the duplicate absolute difference calculations.

Qualifications:

U - Non-detect J - Estimated J+ - Estimated high
 UJ - Estimated non-detect R - Rejected J- - Estimated low

Abbreviations:

MDL - method detection limit RPD - relative percent difference
 RL - reporting limit %R - percent recovery

References:

CFRSSI QAPP - ARCO, 1992. Clark Fork River Superfund Site Investigations (CFRSSI) Quality Assurance Project Plan (QAPP). Prepared for ARCO by PTI Environmental Services, Bellevue, Washington. May 1992.

Appendix E. BRW Phase III Data Validation Quality Control Criteria - Eurofins

ICP-MS (EPA 200.8/EPA 6020)

ICP-AES (EPA 200.7/EPA 6010)

Mercury (EPA 1631E/7471A)

General Chemistry -Anions (EPA 300.0); Alkalinity (SM 2320B); Total Dissolved Solids (SM 2540C); pH (9045D); Specific Conductivity (120.1); Phosphorus (EPA 365.1); Nitrogen, NO₂ plus NO₃ (EPA 353.2); Percent Moisture (ASTM D2216)

Polychlorinated biphenyl (PCB) (SW-846 8082A)

Dioxins (1613B)

Volatile Petroleum Hydrocarbons (VPH) (MT VPH)

Extractable Petroleum Hydrocarbons (EPH) (MT EPH)

1,2-Dibromoethane (EDB) (SW-846 8011)

1,2-Dichloroethane (DCE) (SW-846 8260B)

Pentachlorophenol (PCP) (SW-846 8270D SIM)

ICP-MS (EPA 200.8 / EPA 6020) - Eurofins								
Quality Control	Frequency	Acceptance Criteria	Criteria	Action			Reference	
				Associated Sample Result Detected	Associated Sample Result Non-Detected	Reason Code		
Holding Time	Every sample	≤180 Days	Hold Time > 180 Days	J-	Professional Judgement UJ or R	H	NFG	
Preservation	Every sample	pH ≤ 2 (water)	Samples received with pH > 2 and pH not adjusted	Professional Judgement J-	Professional Judgement R	Pres	NFG	
Method Blank (MB)	MB - Each analytical batch of samples for every 20 (or fewer) samples received	absolute value of blank result ≤ 2x MDL	blank result < 2x MDL	No Qualification	No Qualification	MB	CFRSSI QAPP	
			Positive blank result > 2x MDL	Results < 5x blank result U	No Qualification			
			absolute value of negative blank result > 2x MDL	Results < 5x absolute value of negative blank result J	UJ			
Laboratory Control Sample (LCS)/Laboratory Control Sample Duplicate (LCSD)	1 per batch or 1 per 20 samples. LCSD performed instead of LDS or MSD if insufficient sample is submitted.	%R 85-115% (200.8) %R 80-120% (6020) RPD ≤ 20%	%R < 40%	J-	R	L%	BRW Phase III QAPP NFG Eurofins SOP	
			%R 40-85% (200.8) %R 40-79% (6020)	J-	UJ			
			%R 85-115% (200.8) %R 80-120% (6020)	No Qualification	No Qualification			
			%R > 115% (200.8) %R > 120% (6020)	J+	No Qualification			
			%R > 150%	R	No Qualification			
			RPD > 20%	J	UJ			D%
Laboratory Duplicate Samples (LDS)	Each analytical batch of samples for every 20 (or fewer) samples received	1. If both original sample and duplicate sample results are ≥ 5x RL, then RPD ≤ 20% (water) or RPD ≤ 35% (soils); 2. If original sample or duplicate sample result < 5x RL (including non-detects), then difference between sample and duplicate ≤ RL (water) or ≤ 2x RL (soils)	Both original and duplicate sample results ≥ 5x RL and RPD > 20% (water) or RPD > 35% (soils)	J	UJ	D%	BRW Phase III QAPP NFG	
			Both original and duplicate sample results ≥ 5x RL and RPD ≤ 20% (water) or RPD ≤ 35% (soils)	No Qualification	No Qualification			
			RPD > 100%	Professional Judgement	Professional Judgement			
			Original sample or duplicate sample result is < 5x the RL and difference between the sample and duplicate > RL (water) or > 2x RL (soils)	J	UJ			
			Original sample or duplicate sample result is < 5x the RL and difference between the sample and duplicate ≤ RL or ≤ 2x RL (soils)	No Qualification	No Qualification			

ICP-MS (EPA 200.8 / EPA 6020) - Eurofins												
Quality Control	Frequency	Acceptance Criteria	Criteria	Action			Reference					
				Associated Sample Result Detected	Associated Sample Result Non-Detected	Reason Code						
Matrix Spike (MS)/Matrix Spike Duplicate (MSD)	Each analytical batch of samples for every 20 (or fewer) samples received	%R 70-130% (200.8) %R 80-120% (6020) RPD ≤ 20% If the original sample result is ≥ 4x the spike amount added, the data shall not be flagged even if the %R exceeds the acceptance criteria	Matrix Spike %R < 30% Post-digestion spike %R < 75% (200.8) Post-digestion spike %R < 80% (6020)	J-	R	S%	BRW Phase III QAPP NFG Eurofins SOP					
			Matrix Spike %R < 30% Post-digestion spike %R ≥ 75% (200.8) Post-digestion spike %R ≥ 80% (6020)	J	UJ							
			Matrix Spike %R 30-69% (200.8) Matrix Spike %R 30-79% (6020) Post-digestion Spike %R < 75% (200.8) Post-digestion Spike %R < 80% (6020)	J-	UJ							
			Matrix Spike %R 30-69% (200.8) Matrix Spike %R 30-79% (6020) Post-digestion spike %R ≥ 75% (200.8) Post-digestion spike %R ≥ 80% (6020)	J	UJ							
			Matrix Spike %R >130% (200.8) Matrix Spike %R > 120% (6020) Post-digestion spike %R > 125% (200.8) Post-digestion spike %R > 120% (6020)	J+	No Qualification							
			Matrix Spike %R >130% (200.8) Matrix Spike %R > 120% (6020) Post-digestion spike %R ≤ 125% (200.8) Post-digestion spike %R ≤ 120% (6020)	J	No Qualification							
			Matrix Spike %R < 30% No post-digestion spike performed	J-	R							
			Matrix Spike %R 30-69% (200.8) Matrix Spike %R 30-79% (6020) No post-digestion spike performed	J-	UJ							
			Matrix Spike %R 70-130% (200.8) Matrix Spike %R 80-120% (6020) No post-digestion spike is required	No Qualification	No Qualification							
			Matrix Spike %R >130% (200.8) Matrix Spike %R > 120% (6020) No post-digestion spike performed	J+	No Qualification							
			Sample analyte concentration ≥ 4x spike concentration	No Qualification	No Qualification							
			RPD > 20%	J	UJ			D%				
			Serial Dilution (SD)	Each analytical batch of samples.	≤ 20% if sample concentration is sufficiently high			Sample >50x MDL and SD ≥ RL and %D > 20%	J	UJ	SD	NFG
								Sample >50x MDL and SD ≥ RL and %D ≥ 100%	Professional Judgement	Professional Judgement		
Sample > 50x MDL and SD < RL	No Qualification	No Qualification										
Interferences present	Professional Judgement	Professional Judgement										

ICP-AES (EPA 200.7 / EPA 6010D) - Eurofins								
Quality Control	Frequency	Acceptance Criteria	Criteria	Action			Reference	
				Associated Sample Result Detected	Associated Sample Result Non-Detected	Reason Code		
Holding Time	Every sample	≤ 180 Days	Hold Time > 180 Days	J-	Professional Judgement UJ or R	H	NFG	
Preservation	Every sample	pH ≤ 2 (water)	Samples received with pH > 2 and pH not adjusted	Professional Judgement J-	Professional Judgement R	Pres	NFG	
Method Blank (MB)	MB - Each analytical batch of samples for every 20 (or fewer) samples received	absolute value of blank result ≤ 2x MDL	blank result ≤ 2x MDL	No Qualification	No Qualification	MB	CFRSSI QAPP	
			Positive blank result > 2x MDL	Results < 5x blank result U	No Qualification			
			absolute value of negative blank result > 2x MDL	Results < 5x absolute value of negative blank result J	UJ			
Laboratory Control Sample (LCS)/Laboratory Control Sample Duplicate (LCSD)	1 per batch or 1 per 20 samples. LCSD performed instead of LDS or MSD if insufficient sample is submitted.	%R 85-115% (200.7) %R 80-120% (6010) RPD ≤ 20%	%R < 40%	J-	R	L%	BRW Phase III QAPP NFG Eurofins SOP	
			%R 40-84% (200.7) %R 40-79% (6010)	J-	UJ			
			%R 85-115% (200.7) %R 80-120% (6010)	No Qualification	No Qualification			
			%R > 115% (200.7) %R > 120% (6010)	J+	No Qualification			
			%R > 150%	R	No Qualification			
			RPD > 20%	J	UJ			D%
Laboratory Duplicate Samples (LDS)	Each analytical batch of samples for every 20 (or fewer) samples received	1. If both original sample and duplicate sample results are ≥ 5x RL, then RPD ≤ 20% (water) or RPD ≤ 35% (soils); 2. If original sample or duplicate sample result < 5x RL (including non-detects), then difference between sample and duplicate ≤ RL (water) or ≤ 2x RL (soils)	Both original and duplicate sample results ≥ 5x RL and RPD > 20% (water) or RPD > 35% (soils)	J	UJ	D%	BRW Phase III QAPP NFG	
			Both original and duplicate sample results ≥ 5x RL and RPD ≤ 20% (water) or RPD ≤ 35% (soils)	No Qualification	No Qualification			
			RPD > 100%	Professional Judgement	Professional Judgement			
			Original sample or duplicate sample result is < 5x the RL and difference between the sample and duplicate > RL (water) or > 2x RL (soils)	J	UJ			
			Original sample or duplicate sample result is < 5x the RL and difference between the sample and duplicate ≤ RL or ≤ 2x RL (soils)	No Qualification	No Qualification			

ICP-AES (EPA 200.7 / EPA 6010D) - Eurofins												
Quality Control	Frequency	Acceptance Criteria	Criteria	Action			Reference					
				Associated Sample Result Detected	Associated Sample Result Non-Detected	Reason Code						
Matrix Spike (MS)/Matrix Spike Duplicate (MSD)	One pair per 10 samples (200.7) - OR- Each analytical batch of samples for every 20 (or fewer) samples received (6010)	%R 70-130% (200.7) %R 80-120% (6010) RPD ≤ 20% If the original sample result is ≥ 4x the spike amount added, the data shall not be flagged even if the %R exceeds the acceptance criteria	Matrix Spike %R < 30% Post-digestion spike %R < 85% (200.7) Post-digestion spike %R < 75% (6010)	J-	R	S%	BRW Phase III QAPP NFG Eurofins SOP					
			Matrix Spike %R < 30% Post-digestion spike %R ≥ 85% (200.7) Post-digestion spike %R ≥ 75% (6010)	J	UJ							
			Matrix Spike %R 30-69% (200.7) Matrix Spike %R 30-79% (6010) Post-digestion Spike %R < 85% (200.7) Post-digestion Spike %R < 75% (6010)	J-	UJ							
			Matrix Spike %R 30-69% (200.7) Matrix Spike %R 30-79% (6010) Post-digestion spike %R ≥ 85% (200.7) Post-digestion spike %R ≥ 75% (6010)	J	UJ							
			Matrix Spike %R >130% (200.7) Matrix Spike %R >120% (6010) Post-digestion spike %R > 115% (200.7) Post-digestion spike %R > 125% (6010)	J+	No Qualification							
			Matrix Spike %R >130% (200.7) Matrix Spike %R >120% (6010) Post-digestion spike %R ≤ 115% (200.7) Post-digestion spike %R ≤ 125% (6010)	J	No Qualification							
			Matrix Spike %R < 30% No post-digestion spike performed	J-	R							
			Matrix Spike %R 30-69% (200.7) Matrix Spike %R 30-79% (6010) No post-digestion spike performed	J-	UJ							
			Matrix Spike %R 70-130% (200.7) Matrix Spike %R 80-120% (6010) No post-digestion spike is required	No Qualification	No Qualification							
			Matrix Spike %R >130% (200.7) Matrix Spike %R >120% (6010) No post-digestion spike performed	J+	No Qualification							
			Sample analyte concentration ≥ 4x spike concentration	No Qualification	No Qualification							
			RPD>20%	J	UJ			D%				
			Serial Dilution (SD)	Each analytical batch of samples	%D ≤ 20% if sample concentration is sufficiently high			Sample >50x MDL and SD ≥RL and %D > 20%	J	UJ	SD	NFG
								Sample >50x MDL and SD ≥RL and %D ≥ 100%	Professional Judgement	Professional Judgement		
								Sample > 5x RL and SD <RL	No Qualification	No Qualification		
Interferences present	Professional Judgement	Professional Judgement										

Mercury (1631E/7470A/7471A) - Eurofins							
Quality Control	Frequency	Acceptance Criteria	Criteria	Action			Reference
				Associated Sample Result Detected	Associated Sample Result Non-Detected	Reason Code	
Holding Time	Every sample	28 Days	Hold Time > 28 Days	Professional Judgement J-	Professional Judgement UJ or R	H	NFG
Preservation	Every sample	HNO3 to pH < 2 (water) ≤ 6°C (soil)	Samples received pH > 2 and pH not adjusted (water)	Professional Judgement J-	Professional Judgement UJ or R	Pres	NFG
			Soil samples received > 6°C but ≤ 10°C	Professional Judgement J-	Professional Judgement UJ or R		
			Soil samples received > 10°C	Professional Judgement J-	Professional Judgement UJ or R		
Method Blank (MB)	Each analytical batch of samples for every 20 (or fewer) samples received	absolute value of blank result ≤ 2x MDL	Non-detect or ≤ 2x the MDL	No Qualification	No Qualification	MB	CFRSSI QAPP
			Positive blank result > 2x MDL	Results < 5x blank result U	No Qualification		
			absolute value of negative blank result > 2x MDL	Result < 5x absolute value of negative blank result J	UJ		
Laboratory Control Sample (LCS)	Each analytical batch of samples for every 20 (or fewer) samples received	%R 77-123% (1631E) %R 80-120% (7470A/7471A)	%R < 40%	J-	R	L%	BRW Phase III QAPP CFRSSI QAPP Eurofins SOP
			%R 40-77% (1631E) %R 40-74% (7470A/7471A)	J-	UJ		
			%R 77-123% (1631E) %R 75-125% (7470A/7471A)	No Qualification	No Qualification		
			%R > 123% (1631E) %R > 125% (7470A/7471A)	J+	No Qualification		
			%R > 150%	R	No Qualification		
Laboratory Duplicate Samples (LDS)	Each analytical batch of samples for every 20 (or fewer) samples received	1. If both original sample and duplicate sample results are ≥ 5x RL, then RPD ≤ 20% (water) or RPD ≤ 35% (soils); 2. If original sample or duplicate sample result is < 5x RL (including non-detects), then difference between sample and duplicate ≤ RL (water) or ≤ 2x RL (soils)	Both original and duplicate sample results ≥ 5x RL and RPD > 20% (water) or RPD > 35% (soils)	J	UJ	D%	BRW Phase III QAPP NFG
			Both original and duplicate sample results ≥ 5x RL and RPD ≤ 20% (water) or RPD ≤ 35% (soils)	No Qualification	No Qualification		
			RPD > 100%	Professional Judgement	Professional Judgement		
			Original sample or duplicate sample result is < 5x the RL and difference between the sample and duplicate > RL (water) or > 2x RL (soils)	J	UJ		
			Original sample or duplicate sample result is < 5x the RL and difference between the sample and duplicate ≤ RL or ≤ 2x RL (soils)	No Qualification	No Qualification		
Matrix Spike (MS)	Each analytical batch of samples for every 20 (or fewer) samples received	%R 71-125% (1631E) %R 80-120% (7470A/7471A) If the original sample result is ≥ 4x the spike amount added, the data shall not be flagged even if the %R exceeds the acceptance criteria	%R < 30%	J-	R	S%	NFG Eurofins SOP
			%R 30-71% (1631E) %R 30-79% (7470A/7471A)	J-	UJ		
			%R 71-125% (1631E) %R 80-120% (7470A/7471A)	No Qualification	No Qualification		
			%R > 125% (1631E) %R > 120% (7470A/7471A)	J+	No Qualification		
			Sample analyte concentration ≥ 4x spike concentration	No Qualification	No Qualification		

General Chemistry - Eurofins							
Quality Control	Frequency	Acceptance Criteria	Criteria	Action			Reference
				Associated Sample Result Detect	Associated Sample Result Non-Detect	Reason Code	
Anions (EPA 300.0)							
Holding Time	Every sample	≤ 28 days	Hold Time > 28 days	J	UJ	H	BRW Phase III QAPP Eurofins SOP
Preservation	Every Sample	Water ≤6°C	Samples received > 6°C	Professional Judgement J-	Professional Judgement R	Pres	Eurofins SOP
Method Blank (MB)	1 per batch or 1 per 20 samples	Absolute value of the blank result ≤ 2x MDL	Absolute value of the blank result > 2x MDL	Results < 5x the absolute value of the blank detection U	No Qualification	Pres	CFRSSI QAPP
Laboratory Control Sample (LCS) - OR - Laboratory Fortified Blank (LFB)	1 per batch or 1 per 20 samples	%R 90-110%	%R < 90%	J-	UJ	L%	BRW Phase III QAPP Eurofins SOP
			%R > 110%	J+	No Qualification		
Laboratory Duplicate Sample (LDS)	1 per batch or 1 per 20 samples, may use MSD or LCSD	RPD ≤ 10% for LDS RPD ≤ 15% for MSD/LCSD For sample results greater than 5x RL	RPD > 10% for LDS or RPD > 15% for MSD/LCSD for sample results > 5x RL	J	UJ	D%	BRW Phase III QAPP Eurofins SOP
			sample results less than 5x RL with an absolute difference > RL				
			sample results less than 5x the RL with an absolute difference < RL	No Qualification	No Qualification		
Matrix Spike/ Matrix Spike Duplicate (MS/MSD)	1 per 10 samples.	%R 90-110% If sample analyte concentration < 4x spike concentration	%R < 90%	J-	UJ	S%	BRW Phase III QAPP Eurofins SOP
			%R 90-110%	No Qualification	No Qualification		
			%R > 110%	J+	No Qualification		
			Sample analyte concentration > 4x spike concentration	No Qualification	No Qualification		
Alkalinity (SM 2320B)							
Holding Time	Every sample	≤ 14 days	Hold Time > 14 days	J	UJ	H	BRW Phase III QAPP Eurofins SOP
Preservation	Every Sample	Water ≤6°C	Samples received > 6°C	Professional Judgement J-	Professional Judgement R	Pres	Eurofins SOP
Laboratory Control Sample (LCS)/ Laboratory Control Sample Duplicate (LCSD)	1 per batch or 1 per 20 samples.	%R 85-115% and %RPD ≤ 20%	%R < 85%	J-	UJ	L%	BRW Phase III QAPP Eurofins SOP
			%R > 115%	J+	No Qualification	L%	
			RPD > 20%	J	UJ	D%	
Laboratory Duplicate Sample (LDS)	1 per batch or 1 per 20 samples.	RPD ≤ 20% for sample results greater than 5x RL	RPD > 20% for samples greater than 5x RL	J	UJ	D%	BRW Phase III QAPP Eurofins SOP
			sample results less than 5x RL with an absolute difference > RL				
			sample results less than 5x RL with an absolute difference < RL	No Qualification	No Qualification		

General Chemistry - Eurofins							
Quality Control	Frequency	Acceptance Criteria	Criteria	Action			Reference
				Associated Sample Result Detect	Associated Sample Result Non-Detect	Reason Code	
Total Dissolved Solids (SM 2540C)							
Holding Time	Every sample	≤ 7 days	Hold Time > 7 days	J	UJ	H	BRW Phase III QAPP Eurofins SOP
Preservation	Every Sample	Water ≤6°C	Samples received > 6°C	Professional Judgement J-	Professional Judgement R	Pres	Eurofins SOP
Method Blank (MB)	1 per batch or 1 per 20 samples	Absolute value of the blank result ≤ 2x MDL	Absolute value of the blank result > 2x MDL	Results < 5x the absolute value of the blank detection - U	No Qualification	Pres	CFRSSI QAPP
Laboratory Control Sample (LCS)/ Laboratory Control Sample Duplicate (LCSD)	1 per batch or 1 per 20 samples. LCSD performed instead of LDS if insufficient sample is submitted.	%R 80-120% and %RPD ≤ 20%	%R < 80%	J-	UJ	L%	Eurofins SOP
			%R > 120%	J+	No Qualification	L%	
			RPD > 20%	J	UJ	D%	
Laboratory Duplicate Sample (LDS)	1 per 10 samples.	RPD ≤ 20% for sample results greater than 5x RL	RPD > 20% for samples greater than 5x RL	J	UJ	D%	BRW Phase III QAPP Eurofins SOP
			sample results less than 5x RL with an absolute difference > RL				
			sample results less than 5x RL with an absolute difference < RL	No Qualification	No Qualification		
pH (9045D)							
Holding Time	Every sample	≤ 15 minutes	Hold Time > 15 minutes	J	N/A	H	BRW Phase III QAPP
Preservation	Every Sample	Water ≤6°C	Samples received > 6°C	Professional Judgement J-	Professional Judgement R	Pres	Eurofins SOP
High Check Standard/Low Check Standard	Analyzed when sample is outside calibration range (pH 4 - 10)	Results within ± 0.05 SU of true value	High or Low Standard Check result > ± 0.05 SU of true value	J	N/A	L%	Eurofins SOP
Laboratory Duplicate Sample (LDS)	1 per batch or 1 per 20 samples.	Sample results within ± 0.1 SU of each other	Sample results > ± 0.1 SU of each other	J	N/A	D%	Eurofins SOP

General Chemistry - Eurofins							
Quality Control	Frequency	Acceptance Criteria	Criteria	Action			Reference
				Associated Sample Result Detect	Associated Sample Result Non-Detect	Reason Code	
Specific Conductivity (EPA 120.1)							
Holding Time	Every sample	≤ 28 days	Hold Time > 28 days	J	UJ	H	BRW Phase III QAPP Eurofins SOP
Preservation	Every Sample	Water ≤6°C	Samples received > 6°C	Professional Judgement J-	Professional Judgement R	Pres	Eurofins SOP
Method Blank (MB)	1 per batch or 1 per 20 samples	blank result ≤ 2x MDL	Blank result > 2x MDL	Results < 5x the blank detection U	No Qualification	CCB	CFRSSI QAPP
Laboratory Control Sample (LCS)/ Laboratory Control Sample Duplicate (LCSD)	1 per batch or 1 per 20 samples. LCSD performed instead of LDS if insufficient sample is submitted.	%R 90-110% and %RPD ≤ 20%	%R < 90%	J-	UJ	L%	BRW Phase III QAPP Eurofins SOP
			%R > 110%	J+	No Qualification	L%	
			RPD > 20%	J	UJ	D%	
Laboratory Duplicate Sample (LDS)	1 per batch or 1 per 20 samples	RPD ≤ 20% (waters) -OR- RPD ≤ 35% (soils) for sample results greater than 5x RL	RPD > 20% (waters) -OR- RPD > 35% (soils) for samples > 5x RL	J	UJ	D%	BRW Phase III QAPP Eurofins SOP
			sample results less than 5x RL with an absolute difference > RL				
			sample results less than 5x RL with an absolute difference < RL	No Qualification	No Qualification		
Phosphorus (EPA 365.1)							
Holding Time	Every sample	≤ 28 days	Hold Time > 28 days	J	UJ	H	BRW Phase III QAPP Eurofins SOP
Preservation	Every Sample	H ₂ SO ₄ to pH < 2 ≤ 6°C	Sample received with pH > 2 and pH not adjusted Samples received outside > 6°C	Professional Judgement J-	Professional Judgement R	Pres	BRW Phase III QAPP Eurofins SOP
Method Blank (MB)	MB - Each analytical batch of samples for every 20 (or fewer) samples received.	Absolute value of blank result ≤ 2x MDL	Absolute value of blank result > 2x MDL	Results < 5x the absolute value of the blank detection - U	No Qualification	MB	CFRSSI QAPP
Laboratory Control Sample (LCS)/ Laboratory Control Sample Duplicate (LCSD)	1 per batch or 1 per 20 samples. LCSD performed instead of LDS if insufficient sample is submitted.	%R 90-110% and %RPD ≤ 20%	%R < 90%	J-	UJ	L%	BRW Phase III QAPP Eurofins SOP
			%R > 110%	J+	No Qualification	L%	
			RPD > 20%	J	UJ	D%	
Laboratory Duplicate Samples (LDS)	Each analytical batch of samples for every 20 (or fewer) samples received	RPD ≤ 20% for sample results greater than 5x RL	RPD > 20% for samples > 5x RL	J	UJ	D%	BRW Phase III QAPP Eurofins SOP
			sample results less than 5x RL with an absolute difference > RL				
			sample results less than 5x RL with an absolute difference < RL	No Qualification	No Qualification		
Matrix Spike (MS)	Each analytical batch of samples for every 20 (or fewer) samples received	%R 80-120% If the original sample result is ≥ 4x the spike amount added, the data shall not be flagged even if the %R exceeds the acceptance criteria	%R < 80%	J-	UJ	S%	Eurofins SOP
			%R 80-120%	No Qualification	No Qualification		
			%R > 120%	J+	No Qualification		
			Sample analyte concentration > 4x spike concentration	No Qualification	No Qualification		

General Chemistry - Eurofins							
Quality Control	Frequency	Acceptance Criteria	Criteria	Action			Reference
				Associated Sample Result Detect	Associated Sample Result Non-Detect	Reason Code	
Nitrate and Nitrite (EPA 353.2)							
Holding Time	Every sample	≤ 28 days	Hold Time > 28 days	J	UJ	H	BRW Phase III QAPP Eurofins SOP
Preservation	Every Sample	H ₂ SO ₄ to pH < 2 ≤ 6°C	Sample received with pH > 2 and pH not adjusted Samples received outside > 6°C	Professional Judgement J-	Professional Judgement R	Pres	BRW Phase III QAPP Eurofins SOP
Method Blank (MB)	MB - Each analytical batch of samples for every 20 (or fewer) samples received.	Absolute value of blank result ≤ 2x MDL	Absolute value of blank result > 2x MDL	Results < 5x the absolute value of the blank detection - U	No Qualification	MB	CFRSSI QAPP
Laboratory Control Sample (LCS)/ Laboratory Control Sample Duplicate (LCSD)	1 per batch or 1 per 20 samples. LCSD performed instead of LDS if insufficient sample is submitted.	%R 90-110% and %RPD ≤ 20%	%R < 90%	J-	UJ	L%	BRW Phase III QAPP Eurofins SOP
			%R > 110%	J+	No Qualification	L%	
			RPD > 20%	J	UJ	D%	
Laboratory Duplicate Samples (LDS)	Each analytical batch of samples for every 20 (or fewer) samples received	RPD ≤ 20% for sample results greater than 5x RL	RPD > 20% for samples > 5x RL	J	UJ	D%	BRW Phase III QAPP Eurofins SOP
			sample results less than 5x RL with an absolute difference > RL				
			sample results less than 5x RL with an absolute difference < RL	No Qualification	No Qualification		
Matrix Spike (MS)	1 for every 10 samples analyzed	%R 90-110% If the original sample result is ≥ 4x the spike amount added, the data shall not be flagged even if the %R exceeds the acceptance criteria	%R < 90%	J-	UJ	S%	Eurofins SOP
			%R 90-110%	No Qualification	No Qualification		
			%R > 110%	J+	No Qualification		
			Sample analyte concentration > 4x spike concentration	No Qualification	No Qualification		
Percent Moisture (ASTM D2216)							
Laboratory Duplicate Sample (LDS)	Each analytical batch of samples for every 20 (or fewer) samples received	RPD ≤ 35%	RPD > 35%	J	UJ	D%	CFRSSI QAPP BRW Phase III QAPP

Polychlorinated biphenyl (PCB) (SW-846 8082A) - Eurofins							
Quality Control	Frequency	Acceptance Criteria	Criteria	Action			Reference
				Associated Sample Result Detected	Associated Sample Result Non-Detected	Reason Code	
Holding Time	Every sample	Aqueous Samples properly preserved: ≤ 7 days (for extraction) and ≤ 40 days (for analysis)	Aqueous samples not properly preserved: ≤ 7 days (for extraction) and ≤ 40 days (for analysis)	Use professional judgment	Use professional judgment	H	BRW Phase III QAPP NFG Eurofins SOP
			Aqueous samples not properly preserved: > 7 days (for extraction) and/or > 40 days (for analysis)	J	Use professional judgment		
			Aqueous samples properly preserved: ≤ 7 days (for extraction) and ≤ 40 days (for analysis)	No qualification	No qualification		
			Aqueous samples properly preserved: > 7 days (for extraction) and/or > 40 days (for analysis)	J	U		
			Holding time grossly exceeded	J	Use professional judgment UJ or R		
Preservation	Every sample	≤ 6 °C	Samples received outside > 6°C	See Holding Time	See Holding Time	Pres	NFG
Method Blank (MB)	1 per preparation batch	blank result ≤ 2x MDL	blank result > 2x MDL	Results < 5x blank result U	No Qualification	MB	CFRSSI QAPP
Surrogates	Present in all samples (including QC)	Use Laboratory Statistical Control Limits (%R)	%R < Low Control Limit%	J-	UJ	Sur	Eurofins SOP
			%R > High Control Limit%	J+	No Qualification		
Laboratory Control Sample (LCS)/Laboratory Control Sample Duplicate (LCSD)	Minimum 1/20 samples	Use Laboratory Statistical Control Limits (%R)	%R < Low Control Limit%	J-	UJ	L%	Eurofins SOP
			%R > High Control Limit%	J+	No Qualification		
Matrix Spike/ Matrix Spike Duplicate (MS/MSD)	1/20 samples	Use Laboratory Statistical Control Limits (%R)	%R < Low Control Limit%	J-	UJ	S%	Eurofins SOP
			%R > High Control Limit%	J+	No Qualification		
Laboratory Duplicate Samples (LDS)	1/20 samples	Use Laboratory Statistical Control Limit (RPD)	RPD > Laboratory Statistical Control Limit	J	UJ	D%	Eurofins SOP

Dioxins (EPA 1613B) - Eurofins							
Quality Control	Frequency	Acceptance Criteria	Criteria	Action			Reference
				Associated Sample Result Detected	Associated Sample Result Non-Detected	Reason Code	
Holding Time	Every sample	≤ 1 year collection - extraction	Collection to extraction > 1 year	Professional Judgement J-	Professional Judgement UJ or R	H	BRW Phase III QAPP NFG
		≤ 1 year extraction - analysis	Extraction to analysis > 1 year	Professional Judgement J-	Professional Judgement UJ or R		
Preservation	Every sample	≤ 6°C	Samples received > 6°C	Professional Judgement J	Professional Judgement UJ	Pres	NFG
Labeled Compounds	Present in all extracted samples (including QC)	Use Laboratory Statistical Control Limits (%R)	%R < Low Control Limit%	J-	UJ	LC	NFG Eurofins SOP
			%R > High Control Limit%	J+	No Qualification		
Method Blank (MB)	One per analytical batch	Blank result ≤ 1/2 RL	Blank result > 1/2 RL	Results < 5x blank result U	No Qualification	MB	Eurofins SOP
Laboratory Control Sample (LCS)	Minimum 1/20 samples	Use Laboratory Statistical Control Limits (%R)	%R < Low Control Limit%	J-	UJ	L%	Eurofins SOP
			%R > High Control Limit%	J+	No Qualification		
Matrix Spike (MS)/Matrix Spike Duplicate (MSD)	Minimum 1/20 samples	Use Laboratory Statistical Control Limits (%R)	%R < Low Control Limit%	J-	UJ	L%	Eurofins SOP
			%R > High Control Limit%	J+	No Qualification		
Laboratory Duplicate Samples (LDS)	Each batch of 20 samples/matrix	≤ 50% RPD	> 50% RPD	J	UJ	D%	Eurofins SOP

Volatile Petroleum Hydrocarbons (MT VPH) - Eurofins							
Quality Control	Frequency	Acceptance Criteria	Criteria	Action			Reference
				Associated Sample Result Detected	Associated Sample Result Non-Detected	Reason Code	
Holding Time	Every sample	Soil ≤ 7 days collection - extraction	Collection to extraction > 7 days	J	UJ	H	BRW Phase III QAPP Eurofins SOP
		Soil ≤ 28 days extraction - analysis	Extraction to analysis > 28 days	J	UJ		
		Water ≤ 14 days collection - analysis	Collection to analysis > 14 days	J	UJ		
Preservation	Every sample	Soil ≤ 6°C	Samples received > 6°C	Professional Judgement J-	Professional Judgement R	Pres	BRW Phase III QAPP Eurofins SOP
		Water ≤ 6°C; HCl	Sample received with pH > 2 and pH not adjusted Samples received outside > 6°C	Professional Judgement J-	Professional Judgement R		
Method Blank (MB)	After calibration standards and before samples. Minimum is 1 per batch.	blank result ≤ 2x MDL	blank result > 2x MDL	Results < 5x blank result U	No Qualification	MB	CFRSSI QAPP
Trip Blank	1 per sampling event	blank result ≤ 2x MDL	blank result > 2x MDL	Results < 5x blank result U	No Qualification	TB	CFRSSI QAPP
Surrogates	every samples (including QC)	Use Laboratory Statistical Control Limits	%R < LCL	J-	UJ	Sur	Eurofins SOP
			Within CL	No Qualification	No Qualification		
			%R > UCL	J+	No Qualification		
Laboratory Control Sample (LCS)	1 in 20 or fewer samples	Use Laboratory Statistical Control Limits	%R < LCL	J-	UJ	L%	Eurofins SOP
			Within CL	No Qualification	No Qualification		
			%R > UCL	J+	No Qualification		
Matrix Spike/ Matrix Spike Duplicate (MS/MSD)	1 in 20 or fewer samples	Use Laboratory Statistical Control Limits	%R < LCL	J-	UJ	S%	Eurofins SOP
			Within CL	No Qualification	No Qualification		
			%R > UCL	J+	No Qualification		
Laboratory Duplicate Samples (LDS)	1 in 20 or fewer samples	Use Laboratory Statistical Control Limit	> CL	J	UJ	D%	Eurofins SOP

Extractable Petroleum Hydrocarbons (MT EPH) - Eurofins							
Quality Control	Frequency	Acceptance Criteria	Criteria	Action			Reference
				Associated Sample Result Detected	Associated Sample Result Non-Detected	Reason Code	
Holding Time	Every sample	≤ 14 days collection - extraction	Collection to extraction > 14 days	J	UJ	H	BRW Phase III QAPP Eurofins SOP
		≤ 40 days extraction - analysis	Extraction to analysis > 40 days	J	UJ		
Preservation	Every sample	Soil ≤ 6°C	Samples received > 6°C	Professional Judgement J-	Professional Judgement R	Pres	BRW Phase III QAPP Eurofins SOP
		Water ≤ 6°C; HCl	Sample received with pH > 2 and pH not adjusted Samples received outside > 6°C	Professional Judgement J-	Professional Judgement R		
Surrogates	Present in all extracted samples (including QC)	%R 50-150%	%R < 50%	J-	UJ	Sur	Eurofins SOP
			%R 50-150%	No Qualification	No Qualification		
			%R > 150%	J+	No Qualification		
Method Blank (MB)	One per analytical batch	blank result ≤ 2x MDL	blank result > 2x MDL	Results < 5x blank result U	No Qualification	MB	CFRSSI QAPP
Laboratory Control Sample (LCS)	One per analytical batch	%R 40-140%	%R < 40%	J-	UJ	L%	Eurofins SOP
			%R 40-140%	No Qualification	No Qualification		
			%R > 140%	J+	No Qualification		
Matrix Spike/ Matrix Spike Duplicate (MS/MSD)	One per analytical batch	Use Laboratory Statistical Control Limits (%R)	%R < LCL	J-	UJ	S%	Eurofins SOP
			Within CL	No Qualification	No Qualification		
			%R > UCL	J+	No Qualification		
Laboratory Duplicate Samples (LDS)	One per analytical batch	Use Laboratory Statistical Control Limits (RPD)	RPD > Control Limit	J	UJ	D%	Eurofins SOP

1,2-Dibromoethane (EDB) (SW-846 8011) - Eurofins							
Quality Control	Frequency	Acceptance Criteria	Criteria	Action			Reference
				Associated Sample Result Detected	Associated Sample Result Non-Detected	Reason Code	
Holding Time	Every sample	≤ 14 days	Collection to analysis > 14 days	J	UJ	H	BRW Phase III QAPP Eurofins SOP
Preservation	Every sample	Soil ≤ 6°C	Samples received > 6°C	Professional Judgement J-	Professional Judgement UJ or R	Pres	BRW Phase III QAPP Eurofins SOP
		Water ≤ 6°C; Sodium Thiosulfate	Sample received without Sodium Thiosulfate Samples received outside > 6°C	Professional Judgement J-	Professional Judgement UJ or R		
Method Blank (MB)	1 per preparation batch	blank result ≤ 2x MDL	blank result > 2x MDL	Results < 5x blank result U	No Qualification	MB	CFRSSI QAPP
Surrogates	Present in all samples (including QC)	%R 60-140%	%R < 60%	J-	UJ	Sur	Eurofins SOP
			%R 60-140%	No Qualification	No Qualification		
			%R > 140%	J+	No Qualification		
Laboratory Control Sample (LCS)	1 per preparation batch	%R 60-140%	%R < 60%	J-	UJ	L%	Eurofins SOP
			%R 60-140%	No Qualification	No Qualification		
			%R > 140%	J+	No Qualification		
Matrix Spike/ Matrix Spike Duplicate (MS/MSD)	1 per preparation batch	%R 60-140%	%R < 60%	J-	UJ	S%	Eurofins SOP
			%R 60-140%	No Qualification	No Qualification		
			%R > 140%	J+	No Qualification		
Laboratory Duplicate Samples (LDS)	1 per preparation batch	≤ 20% RPD	> 20% RPD	J	UJ	D%	Eurofins SOP

1,2-Dichloroethane (DCE) (SW-846 8260D) - Eurofins							
Quality Control	Frequency	Acceptance Criteria	Criteria	Action			Reference
				Associated Sample Result Detected	Associated Sample Result Non-Detected	Reason Code	
Holding Time	Every sample	≤14 days	Collection to analysis > 14 days	J	UJ	H	BRW Phase III QAPP Eurofins SOP
Preservation	Every sample	Soil 4°C±2°C	Samples received outside 4°C+2°C	Professional Judgement J-	Professional Judgement R	Pres	BRW Phase III QAPP Eurofins SOP
		Water 4°C ±2°C; HCl	Sample received with pH > 2 and pH not adjusted Samples received outside > 6°C	Professional Judgement J-	Professional Judgement R		
Method Blank (MB)	One per batch of 20 field samples or fewer. Analyzed after calibration standards prior to sample analysis	Blank result ≤ 2x MDL	blank result > 2x MDL	Results < 5x blank result U	No Qualification	MB	CFRSSI QAPP
Surrogates	All field and QC samples.	Use Laboratory Statistical Control Limits (%R)	%R < Low Control Limit%	J-	UJ	Sur	Eurofins SOP
			%R > High Control Limit%	J+	No Qualification		
Laboratory Control Sample (LCS)	One per batch of 20 field samples or fewer.	Use Laboratory Statistical Control Limits (%R)	%R < Low Control Limit%	J-	UJ	L%	Eurofins SOP
			%R > High Control Limit%	J+	No Qualification		
Matrix Spike/ Matrix Spike Duplicate (MS/MSD)	One per lot of 20 field samples or fewer.	Use Laboratory Statistical Control Limits (%R)	%R < Low Control Limit%	J-	UJ	S%	Eurofins SOP
			%R > High Control Limit%	J+	No Qualification		
Laboratory Duplicate Samples (LDS)	One per lot of 20 field samples or fewer.	Use Laboratory Statistical Control Limits (RPD)	RPD > Control Limit	J	UJ	D%	Eurofins SOP

Pentachlorophenol (PCP) (SW-846 8270D SIM) - Eurofins							
Quality Control	Frequency	Acceptance Criteria	Criteria	Action			Reference
				Associated Sample Result Detected	Associated Sample Result Non-Detected	Reason Code	
Holding Time	Every sample	Water ≤ 7 days Soil ≤ 14 days collection - extraction	Collection to extraction > 14 days	J	UJ	H	BRW Phase III QAPP Eurofins SOP
		≤40 days extraction - analysis	Extraction to analysis > 40 days	J	UJ		
Preservation	Every sample	Soil ≤ 6°C	Samples received > 6°C	Professional Judgement J-	Professional Judgement R	Pres	BRW Phase III QAPP Eurofins SOP
		Water ≤ 6°C	Samples received > 6°C	Professional Judgement J-	Professional Judgement R		
Method Blank (MB)	One per batch of 20 field samples or fewer.	Blank result ≤ 2x MDL	blank result > 2x MDL	Results < 5x blank result U	No Qualification	MB	CFRSSI QAPP
Surrogates	All field and QC samples.	Use Laboratory Statistical Control Limits (%R)	%R < Low Control Limit%	J-	UJ	Sur	Eurofins SOP
			%R > High Control Limit%	J+	No Qualification		
Laboratory Control Sample (LCS)	One per batch of 20 field samples or fewer.	Use Laboratory Statistical Control Limits (%R)	%R < Low Control Limit%	J-	UJ	L%	Eurofins SOP
			%R > High Control Limit%	J+	No Qualification		
Matrix Spike/ Matrix Spike Duplicate (MS/MSD)	One per batch of 20 field samples or fewer.	Use Laboratory Statistical Control Limits (%R)	%R < Low Control Limit%	J-	UJ	S%	Eurofins SOP
			%R > High Control Limit%	J+	No Qualification		
Laboratory Duplicate Samples (LDS)	One per batch of 20 field samples or fewer.	Use Laboratory Statistical Control Limits (RPD)	RPD > Control Limit%	J	UJ	D%	Eurofins SOP

Notes:

1. Associated sample results:

For MB and LCS results that do not meet technical criteria, apply action to all samples in the analytical batch.

For LDS, LMS/MSD, and SD results that do not meet technical criteria, apply action to the parent sample and, per the NFG, "apply the action to all samples of the same matrix if the samples are considered sufficiently similar."

For holding time and preservation results that do not meet technical criteria, apply action to sample.

For Dioxins Labeled Compounds, if 37Cl4-2,3,7,8-TCDD is outside laboratory control limits apply, action to all target compounds in that sample. For all other Labeled Compounds outside laboratory control limits, apply action only to the associated target compound in that sample.

2. For consistency in validations between validators, if a sample result is reported as non-detect, the MDL is used for the duplicate absolute difference calculations.

3. An LCS, an LMS, or an original sample may all be used to perform a laboratory duplicate. If a LCS Duplicate or LMS Duplicate is used, the QC sample must also meet the applicable %R technical criteria.

Qualifications:

U - Non-detect J - Estimated J+ - Estimated high
 UJ - Estimated non-detect R - Rejected J- - Estimated low

Abbreviations:

MDL - method detection limit %D - percent difference CL - control limit
 RL - reporting limit %R - percent recovery UCL - upper control limit
 RPD - relative percent difference su - standard units LCL - lower control limit

References:

CFRSSI QAPP - ARCO, 1992. Clark Fork River Superfund Site Investigations (CFRSSI) Quality Assurance Project Plan (QAPP). Prepared for ARCO by PTI Environmental Services, Bellevue, Washington. May 1992.

NFG - EPA, 2020. National Functional Guidelines for Inorganic Superfund Methods Data Review. November 2020.

-- Available at EPA's Superfund Analytical Services and Contract Laboratory Program website: <https://www.epa.gov/clp/contract-laboratory-program-national-functional-guidelines-data-review>

Eurofins SOP -

EPA 200.8/6020 - EFGS-T-MET-SOP41304: Inductively Coupled Plasma-Mass Spectrometry (ICP-MS) (Methods 6020, 6020A, 6020B, 200.8)
 EPA 200.7/6010D - EFGS-T-MET-SOP41265: Trace Metals Analysis by ICP (Methods 6010B, 6010C, 6010D, and 200.7)
 EPA 300.0 - SOP No. TA-WC-0161, Rev. 28: Anions by Ion Chromatography (Methods 300.0, 6056A)

SM 2320B -	EFGS-T-WC-SOP41381: Alkalinity by Titration (Methods 310.0, SM2320B)
SM 2540C -	SOP No. TA-WC-0125, Rev. 18: Determination of Solids in Waters and Wastes (Methods SM 2540B, SM 2540C, SM 2540D, EPA 160.1, 160.2, and 160.3)
9045D -	SOP No. TA-WC-0122, Rev. 22: pH and Corosivity (Methods 150.1, 9040B, 9040C, 9045C, 9045D, and SM 4500-H ⁺ B)
EPA 120.1 -	SOP No. TA-WC-0129, Rev. 17: Conductivity (Methods 120.1 and SM 2510B)
EPA 365.1 -	EFGS-T-WC-SOP41116: Orthophosphate and Total Phosphorus (Method 365.1, 4500_P_F, 365.1 Ortho, 4500_P_F Ortho) (QuikChem 10-115-01-1-A)
EPA 353.2 -	SOP No. TA-WC-0187, Rev. 13.2: Determination of Nitrate-Nitrite in Water (DEPA 353.2 & SM 4500-NO ₃ I) (OIA Publication 26180109)
SW-846 8082A -	SOP No. TA-GS-0351, Rev. 26: PCBs (Methods 8082 and 8082A)
EPA 1613B -	SOP No. WS-ID-0007, Rev. 4.4: Analysis of Tetra-through Octa Chlorinated Dioxins and Furans by Isotope Dilution HRGC/HRMS by Method 1613B (Method 1613B)
MT VPH -	SOP No. TA-GV-0390, Rev. 17: Determination of Volatile Petroleum Hydrocarbons (VPH) Fractions According to WDOE Methodology (Method NWTPH VPH and MTVPH)
MT EPH -	SOP No. TA-GS-0356, Rev. 16: Determination of Extractable Petroleum Hydrocarbons (EPH) Fractions According to WDOE Methodology & Montana Methodology
SW-846 8011 -	SOP No. TA-GS-0365, Rev. 16: Determination of EDB, DBCP, and TCP by GC-ECD (Methods SW 8011 and EPA 504.1)
SW-846 8260D -	SOP No. TA-MV-0314, Rev. 2: Determination of Volatile Organic Compounds by GC/MS (Methods 8260D)
SW-846 8270D SIM -	SOP No. TA-MS-0317, Rev. 1: Semivolatile Organic Compounds (Bae/Neutrals and Acids) Analysis by GC/MS (Method 8270E)

Appendix E. BRW Phase III Data Validation QC Criteria - XRF
XRF

XRF								
Quality Control	Frequency	Acceptance Criteria	Criteria	Action			Reference	
				Associated Sample Result Detected	Associated Sample Result Non-Detected	Reason Code		
System Check	Performed daily, prior to sample analysis	Performed daily, prior to sample analysis	System Check not performed	Professional Judgment J/R	Professional Judgment UJ/R	CX	SOP-SFM-02	
		Resolution < 195	Resolution ≥ 195	Professional Judgment J/R	Professional Judgment UJ/R	SC		
SiO ₂ Standard	Performed daily, prior to sample analysis, at least 1 for every 20 sample analyses, and at end of each day of analysis	Performed daily, prior to sample analysis, at least 1 for every 20 sample analyses, and at end of each day of analysis	Frequency criteria not met	J	UJ	CX	SOP-SFM-02 Niton XL3 Mining QC Sheet	
		Arsenic ≤10 mg/kg	>10 mg/kg	Results < 10x the SiO ₂ result J+	No Qualification	B		
		Cadmium ≤50 mg/kg	>50 mg/kg					
		Calcium ≤2000 mg/kg	>2000 mg/kg					
		Chromium ≤120 mg/kg	>120 mg/kg					
		Copper ≤20 mg/kg	>20 mg/kg					
		Iron ≤50 mg/kg	>50 mg/kg					
		Lead ≤10 mg/kg	>10 mg/kg					
		Manganese ≤300 mg/kg	>300 mg/kg					
		Mercury ≤10 mg/kg	>10 mg/kg					
Silver ≤30 mg/kg	>30 mg/kg							
Zinc ≤10 mg/kg	>10 mg/kg							
Calibration Check Samples	Performed daily, prior to sample analysis, at least 1 for every 20 sample analyses, and at end of each day of analysis	Performed daily, prior to sample analysis, at least 1 for every 20 sample analyses, and at end of each day of analysis	Frequency criteria not met	J	UJ	CX	SOP-SFM-02 Niton XL3 Mining QC Sheet	
		NIST Standard	Arsenic 0 - 35 mg/kg	< Lower Control Limit	J-	UJ		CSS
			Cadmium 0 - 60 mg/kg					
			Calcium 13,900 - 23,900 mg/kg					
			Chromium 50 - 200 mg/kg					
			Copper 0 - 60 mg/kg					
			Iron 25,000 - 35,000 mg/kg					
			Lead 0 - 35 mg/kg					
			Manganese 0 - 700 mg/kg					
			Mercury 0 - 12 mg/kg					
Silver 0 - 40 mg/kg								
Zinc 50 - 160 mg/kg								
RCRA Standard	Arsenic 400 - 600 mg/kg	> Upper Control Limit	J+	No Qualification				
	Cadmium 400 - 600 mg/kg							
	Chromium 400 - 600 mg/kg							
	Lead 400 - 600 mg/kg							
	Silver 400 - 600 mg/kg							
XRF Duplicate	1 per 20 samples	RPD ≤ 35% for detected results	Frequency criteria not met	J	UJ	DX	SOP-SFM-02	
			RPD ≤ 35%	No Qualification	No Qualification	D%		
			RPD > 35%	J	UJ			
XRF Replicate	1 per 20 samples	RPD ≤ 35% for detected results	Frequency criteria not met	J	UJ	RX	SOP-SFM-02	
			RPD ≤ 35%	No Qualification	No Qualification	R%		
			RPD > 35%	J	UJ			

- Notes:**
- Associated sample results:
 - For SiO₂ and Calibration Check Sample results that do not meet technical criteria, apply action to all samples in the analytical batch.
 - For XRF Duplicate and XRF Replicate results that do not meet technical criteria, apply action to the parent sample and, per the NFG, "apply the action to all samples of the same matrix if the samples are considered sufficiently similar."
 - For consistency in validations between validators, if a sample result is reported as non-detect, the MDL is used for the duplicate absolute difference calculations.

Qualifications: UJ - Estimated non-detect J- - Estimated low J - Estimated
 J+ - Estimated high R - Rejected

Abbreviations: mg/kg - milligrams per kilogram
 RPD - relative percent difference

References:
 SOP-SFM-02 - Operating XL3-X-Ray Fluorescence Analyzer General. Pioneer Technical Services, Inc. January 2018.
 Niton XL3 Soil QC Sheet - Niton XL3 Soil QC Certificate of Calibration. Thermo Fisher Scientific. June 2014.